



Designation: ~~D4272/D4272M—15~~ D4272/D4272M – 23

Standard Test Method for Total Energy Impact of Plastic Films by Dart Drop¹

This standard is issued under the fixed designation D4272/D4272M; the number immediately following the designation indicates the year of original adoption or, in the case of revision, the year of last revision. A number in parentheses indicates the year of last reappraisal. A superscript epsilon (ϵ) indicates an editorial change since the last revision or reappraisal.

1. Scope*

1.1 This test method describes the determination of the total energy impact of plastic films by measuring the kinetic energy lost by a free-falling dart that passes through the film.

1.2 *Units*—The values stated in either SI units or inch-pound units are to be regarded separately as standard. The values stated in each system may not be exact equivalents; therefore, each system shall be used independently of the other. Combining values from the two systems may result in non-conformance with the standard

1.3 *This standard does not purport to address all of the safety concerns, if any, associated with its use. It is the responsibility of the user of this standard to establish appropriate ~~safety and health~~safety, health, and environmental practices and determine the applicability of regulatory limitations prior to use.*

NOTE 1—Film has been arbitrarily defined as sheeting having nominal thickness not greater than 0.25 mm [0.010 in.].

NOTE 2—This test method and ISO 7765–2 address the same subject matter, but differ in technical content (and results cannot be directly compared between the two test methods). The ISO test method calls for a direct readout of energy by using a load cell as part of the impactor head, while Test Method D4272 calls for a constant weight impactor, then measuring the time of travel through a given distance to get energy values.

1.4 This international standard was developed in accordance with internationally recognized principles on standardization established in the Decision on Principles for the Development of International Standards, Guides and Recommendations issued by the World Trade Organization Technical Barriers to Trade (TBT) Committee.

2. Referenced Documents

2.1 ASTM Standards:²

[D618 Practice for Conditioning Plastics for Testing](#)

[D883 Terminology Relating to Plastics](#)

[D1709 Test Methods for Impact Resistance of Plastic Film by the Free-Falling Dart Method](#)

[D3420 Test Method for Pendulum Impact Resistance of Plastic Film](#)

[D6988 Guide for Determination of Thickness of Plastic Film Test Specimens](#)

[E171/E171M Practice for Conditioning and Testing Flexible Barrier Packaging](#)

[E456 Terminology Relating to Quality and Statistics](#)

[E691 Practice for Conducting an Interlaboratory Study to Determine the Precision of a Test Method](#)

¹ This test method is under the jurisdiction of ASTM Committee D20 on Plastics and is the direct responsibility of Subcommittee D20.19 on Film, Sheeting, and Molded Products.

Current edition approved Oct. 1, 2015 Aug. 1, 2023. Published October 2015 August 2023. Originally approved in 1983. Last previous edition approved in 2014 2015 as ~~D4272—14~~ D4272/D4272M - 15. DOI: ~~10.1520/D4272—D4272M-15~~ 10.1520/D4272_D4272M-23.

² For referenced ASTM standards, visit the ASTM website, www.astm.org, or contact ASTM Customer Service at service@astm.org. For *Annual Book of ASTM Standards* volume information, refer to the standard's Document Summary page on the ASTM website.

*A Summary of Changes section appears at the end of this standard

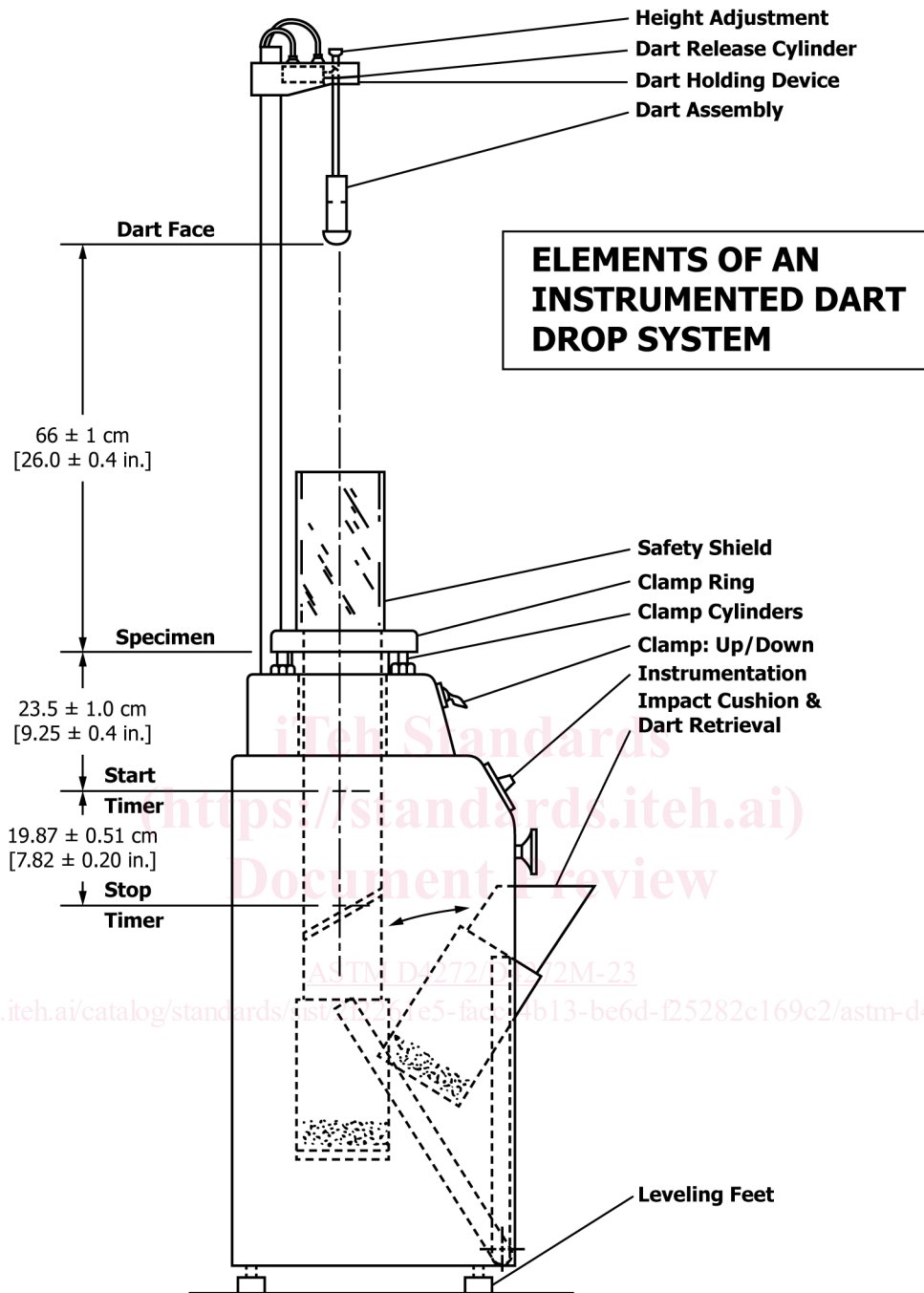

FIG. 1 Elements of an Instrumented Dart Drop System

2.2 ISO Standard:³

ISO 7765-2 Plastics Film and Sheeting—Determination of Impact Resistance by the Free Falling Dart Method—Part 2: Instrumented Puncture Test

3. Terminology

3.1 Terminology—For definitions, see Terms used in this standard are defined in accordance with Terminology D883, unless otherwise specified. For terms relating to precision and bias and associated issues, the terms used in this standard are defined in accordance with Terminology E456.

³ Available from American National Standards Institute (ANSI), 25 W. 43rd St., 4th Floor, New York, NY 10036, <http://www.ansi.org>.

3.2 Definitions of Terms Specific to This Standard:

3.2.1 *free-fall time*—the measured time required for the dart to travel through the sensing area with no film specimen in the clamp.

3.2.2 *missile mass (SI units)*—the total mass of the dart (kg) including any attached incremental weights and the locking collar.

3.2.3 *missile weight (in.-lb units)*—the total weight of the dart (lb) including any attached incremental weights and the locking collar.

3.2.3.1 Discussion—

In the energy calculation, the weight is divided by the gravitational constant, “g” to obtain the mass.

3.2.4 *test-fall time*—the measured time for the dart to travel through the sensing area with a film specimen in the clamp.

4. Summary of Test Method

4.1 The velocity of a freely falling dart of specified shape that has passed through a sheet of plastic film is determined by means of a photoelectric speed trap. The kinetic energy corresponding to this velocity is calculated and compared with the kinetic energy of the same dart measured without a plastic film in place. The loss in kinetic energy of the dart due to rupturing of the film is used as an index of impact resistance.

5. Significance and Use

5.1 Evaluation of the impact toughness of film is important in predicting the performance of a material in applications such as packaging, construction, and other uses. The test simulates the action encountered in applications where moderate-velocity blunt impacts occur in relatively small areas of film.

5.2 The values obtained by this test method are highly dependent on the method and conditions of film fabrication as well as the type and grade of resin.

5.3 Test methods employing different missile velocities, impinging surface diameters, or effective specimen diameters will most likely produce different results. Data obtained by this test method cannot necessarily be compared directly with those obtained by other test methods.

5.4 The impact resistance of a film, while partly dependent on thickness, does not have a simple correlation with sample thickness. Hence, impact values expressed in joules [ft·lbf] normalized over a range of thickness will not necessarily be linear with thickness. Data from this test method are comparable only for specimens that vary by no more than $\pm 15\%$ from the nominal or average thickness of the specimens tested.

5.5 The test results obtained by this test method are greatly influenced by the quality of film under test. The influence of variability of data obtained by this procedure will, therefore, depend strongly on the sample quality, uniformity of film thickness, the presence of die marks, contaminants, etc.

5.6 Several impact test methods are used for film. It is sometimes desirable to know the relationships among test results derived by different test methods. A study was conducted in which four films made from two resins (polypropylene and linear low-density polyethylene), with two film thicknesses for each resin, were impacted using Test Methods **D1709** (Test Method A), Test Method **D3420** (Procedures A and B), and Test Method **D4272**. The test results are shown in **Appendix X2**. Differences in results between Test Methods **D1709** and **D3420** are expected since Test Method **D1709** represents failure-initiated energy, while Test Method **D4272** is initiation plus completion energy. Some films may—It is possible some films show consistency when the initiation energy is the same as the total energy. This statement and the test data also appear in the significance and appendixes sections of Test Methods **D1709** and **D3420**.

6. Apparatus

6.1 The test apparatus shall be constructed essentially as shown in **Fig. 1** and include the following:

6.1.1 A rigid base containing a specimen clamping device, a light sensitive speed trap, and a dart well or chamber for catching and retrieving the dart after impact.

6.1.2 A rigid fixture for holding the dart at the proper height above the film surface. In some equipment designs the dart holding fixture is an integral part of the base unit.

6.1.3 The dimensions of the impact apparatus shall conform to those shown in Fig. 1 and those listed below.

6.2 Specific Requirements for Individual Components:

6.2.1 *Base*—The base shall be rigid enough to prevent movement between the specimen clamp and components of the timing system during impact. It shall be located on a flat surface that provides adequate support to prevent downward movement of the unit during impact. It shall be leveled to insure that the impact surface of the specimen is exactly perpendicular to the trajectory of the dart.

6.2.2 *Specimen Clamp*—The apparatus shall be equipped with a circular clamp to hold the specimen. The clamp shall be mechanically, pneumatically, or hydraulically actuated. The diameter of the clamped area shall be 127 ± 2 mm [5.0 ± 0.1 in.]. In some equipment designs the clamping surface is equipped with rubber O-rings, round gaskets or other circular devices to prevent slippage of the specimen during impact. The clamp shall hold the specimen so that the impact surface is exactly perpendicular to the trajectory of the dart and at the correct distance from the tip of the dart. During impact, the specimen shall be held with enough force to prevent slippage but not great enough to distort, fracture, or otherwise damage the specimen in such a way as to affect the impact strength of the film.

6.2.3 *Light-Sensitive Speed Trap*—A system comprised of photocells, lasers, or other non-mechanical devices connected to the timing device to measure the time-of-flight of the dart. The distance from the bottom surface of the specimen to the upper (starting) sensor shall be 23.5 ± 1.0 cm [9.25 ± 0.40 in.]. The length of the speed trap, that is, the distance between the starting and stopping sensors shall be 19.87 ± 0.51 cm [7.82 ± 0.20 in.].

6.2.4 *Timing Device*—An electronic timer capable of measuring to the nearest 10^{-5} s.

6.2.5 *Dart Well*—The bottom of the dart well shall contain adequate cushioning material to prevent damage to the dart head. If the impact machine utilizes an enclosed dart well, it must contain a single unobstructed vent with a minimum area of 645 mm^2 [$\sim 1 \text{ in.}^2$] to provide adequate venting.

NOTE 3—Some dart impact machine designs utilize enclosed dart wells that do not permit adequate venting to the atmosphere during impact. Data have shown that this has a significant effect on the observed impact value, especially with films that exhibit high elongation during testing, resulting in atypically high impact values.

NOTE 4—The use of smaller, multiple vents is permitted if it can be demonstrated that the venting efficiency is comparable and has no statistically significant effect on the values obtained.

6.2.6 *Dart Holding Fixture*—An electromagnetic, pneumatic, or mechanical system to suspend the dart in position above the test specimen. It shall be adjustable vertically and horizontally relative to the impact surface to insure that the dart falls from the correct height and directly onto the center of the clamped specimen. In some equipment designs, this fixture is an integral part of the base. When the dart is in position to drop, the distance between the lower tip of the dart and the upper surface of the specimen shall be 66 ± 1 cm [26.0 ± 0.4 in.]. A plumb bob shall be used to precisely center the fixture over the specimen clamp to insure that the dart strikes the center of the specimen. The fixture shall release the dart without imparting any vertical or horizontal force that might affect the trajectory of the dart.

6.2.7 *Dart*—The impact dart shall have a single 38.10 ± 0.13 mm [1.500 ± 0.005 in.] diameter hemispherical stainless steel head. It shall have a mass of 227 ± 5 g [0.50 ± 0.01 lb] and a shaft of sufficient length and diameter to accommodate any additional weights used to increase the mass of the dart. The shaft shall be attached to the center of the flat surface of the dart head with its longitudinal axis perpendicular to the surface. The impact surface of the dart head shall be free of nicks, scratches, or other irregularities.

NOTE 5—A stem diameter of 9.52 mm [0.37 in.] has been found to be satisfactory to resist bending.

NOTE 6—Data have shown a sensitivity of impact results related to the condition and finish of the dart head used. The differences have been especially significant when testing films exhibiting high impact, or high elongation characteristics, or both. This issue, together with related concerns, is currently under study in Subcommittee D20.19.

6.2.8 *Dart Weights*—Weights to increase the mass of the dart in 227 ± 5 g [0.50 ± 0.01 lb] increments to a total of 1135 ± 25 g [2.50 ± 0.05 lb]. The diameter of the weights shall be 31.8 mm [1.25 in.] or less and they shall attach securely to the dart stem. Weights shall be of rigid, metallic construction, that is, not filled with lead shot or other loose material. In adjusting the mass of the dart, incremental weights are added individually or as a single weight equivalent to the appropriate mass. If single weights are used, their masses shall vary in 227 g [0.5 lb] increments.

6.3 *Other Required Equipment:*

6.3.1 *Micrometer (or other suitable thickness gauge)*—For measuring specimen thickness in accordance with Guide D6988.

6.3.2 *Plumb Bob*—For adjusting the dart holding fixture so that the dart strikes the specimen in the center of the specimen clamp.

7. Test Specimens

7.1 The minimum size for a single determination is at least 165.0 by 152.5 mm [6.5 by 6 in.]. However, for convenience in handling, 165.0 by 200 mm [6.5 by 8 in.] is preferred, or a roll 165.0 mm wide can be fed.

7.2 The specimens shall be representative of the film under study and shall be taken from the sample sheet in a manner representative of sound sampling practice.

7.3 The sample shall be free of pinholes, wrinkles, folds, or other obvious imperfections, unless such imperfections are the variables under study.

7.4 A minimum of five test specimens is required to obtain a reliable test result for a film sample.

7.5 The film shall be identified with material, roll or lot number, extruder (if known), type (blown or cast), date of manufacture, treatment, sample source, and date of receipt.

7.6 Measure and record the thickness of the film specimens in accordance with Guide D6988. Reject samples that vary by more than 15 % from the nominal or average thickness.

8. Preparation of Apparatus

8.1 Turn on the counter and the power supply for the light-sensing unit and allow to warm up in sufficient time to reach equilibrium. (See manufacturer's instructions.)

8.2 Without prior knowledge of the impact resistance of the film tested or specific instructions, use a 908 g [2 lb] dart weight at 66 cm [26 in.] height.

8.3 Position the dart vertically in the holder and clamp the dart with the dart-holding device. Allow a few seconds for any vibration to subside and release the dart. Record the free-fall time.

8.4 Repeat 8.3 four more times. Average the five measured times and record as t_1 .

8.4.1 The time reading of each of the five free-falls shall be within ± 30 μ s of the average. If it is not, check the timing system, the position of the sensing element, etc. until this repeatability is obtained with five free-falls.

8.4.2 The dart shall not vibrate or rotate in the holder and shall fall straight.

8.4.3 To ensure consistency in drop of the dart and position of impact of the dart on the film, the dart tip next to the holder can be scribed so that it can be lined up in the same position each time.

9. Conditioning

9.1 *Conditioning*—Condition the test specimens at $23 \pm 2^\circ\text{C}$ [$73.4 \pm 3.6^\circ\text{F}$] and $50 \pm 10\%$ relative humidity for not less than 40 h prior to test in accordance with Procedure A of Practice **D618** unless otherwise specified by agreement or the relevant ASTM material specification. In cases of disagreement, the tolerances shall be $\pm 1^\circ\text{C}$ [$\pm 1.8^\circ\text{F}$] and $\pm 5\%$ relative humidity.

9.2 *Test Conditions*—Conduct the tests at $23 \pm 2^\circ\text{C}$ [$73.4 \pm 3.6^\circ\text{F}$] and $50 \pm 10\%$ relative humidity unless otherwise specified by agreement or the relevant ASTM material specification. In cases of disagreement, the tolerances shall be $\pm 1^\circ\text{C}$ [$\pm 1.8^\circ\text{F}$] and $\pm 5\%$ relative humidity.

10. Test Procedure

10.1 Place the specimen over the bottom part of the clamp, making sure that it is uniformly flat, that it is free of wrinkles and folds, and that it covers the gasket, O-ring, or other mounting surface at all points.

10.2 Clamp the specimen in place.

10.3 Position the dart vertically in the holder and clamp the dart with the dart-holding device.

10.4 Wait a few seconds for any vibrations to subside.

10.5 Release the dart. The dart shall fall straight.

10.6 Record the test-fall time, t_2 .

10.7 Examine the film to determine the type of failure: for example, hole, tear, shatter, etc. Some ductile materials cause deflection of the dart, thus causing erroneous results. Such materials shall be retested using a heavier dart.

10.8 Repeat **10.1 – 10.7** for the remaining specimens.

11. Calculation

[ASTM D4272/D4272M-23](https://standards.iteh.ai/catalog/standards/sist/2f2261e5-facc-4b13-be6d-f25282c169c2/astm-d4272-d4272m-23)

<https://standards.iteh.ai/catalog/standards/sist/2f2261e5-facc-4b13-be6d-f25282c169c2/astm-d4272-d4272m-23>

11.1 Calculate the energy to rupture for each test specimen as follows (the derivation of the equation is given in **Appendix X1**):

In SI units:

$$E = \frac{m}{2} \left[d^2 \left(\frac{1}{t_1^2} - \frac{1}{t_2^2} \right) + \frac{g^2}{4} (t_1^2 - t_2^2) \right] \quad (1)$$

where:

E = energy to rupture, J,
 m = missile mass, kg,
 g = gravitational constant, 9.81 m/s^2 ,
 d = distance between sensing elements, m,
 t_1 = average free-fall time, s, and
 t_2 = test-fall time, s.

In inch-pound units:

$$E = \frac{W}{2g} \left[d^2 \left(\frac{1}{t_1^2} - \frac{1}{t_2^2} \right) + \frac{g^2}{4} (t_1^2 - t_2^2) \right] \quad (2)$$

where:

E = energy to rupture, ft-lbf,
 W = missile weight, lb,
 g = gravitational constant, 32.2 ft/s^2 ,
 d = distance between sensing elements, ft,



t_1 = average free-fall time, s, and
 t_2 = test-fall time, s.

11.2 Calculate the energy to rupture for the film sample as the average of the five energy values for the test specimens.

NOTE 7—Equations 1 and 2 were reviewed and corrected to reflect the appropriate use and conversions of mass/weight and energy units.

NOTE 8—It is possible to obtain an approximate conversion of the results obtained using Eq 1 in SI units to inch-pound units and vice-versa, as follows: 1 ft-lbf \approx 1.356 J or 1 J \approx 0.7376 ft-lbf.

12. Report

12.1 Report the following information:

12.1.1 Complete identification and description of the material tested, including type, source, manufacturer’s code, principle dimensions, and previous history.

12.1.2 Energy to rupture for film sample, J [ft-lbf].

12.1.3 Type of break.

12.1.4 Average thickness and range of thickness for specimens tested to nearest 0.0025 mm [0.0001 in.].

12.1.5 Date of test.

12.1.6 Manufacturer and test instrument model number.

12.1.7 Missile mass, kg (SI units) or missile weight, lb (in.-lb units).

13. Precision and Bias⁴

13.1 ~~Table 1 and~~ The precision ~~Table 2~~ are based on a round robin conducted in 1982 in accordance with Practice of this test method is based on an interlaboratory study conducted in 1982, E691, involving three materials tested by nine laboratories. For each material, all samples and test specimens were prepared at one source. Each test result was the average impact resistance from a test of five individual determinations. Each laboratory obtained five test results for each material. (Warning—The explanation of “r” and “R” (13.2 through 13.2.3) are only intended to present a meaningful way of considering the approximate precision of this test method. The data in Tables 1 and 2 should shall not be applied to acceptance or rejection of materials, as these data apply only to the materials tested in this round robin, and are unlikely to be rigorously representative of other lots, formulations, conditions, materials, or laboratories. Users of this test method shall apply the principles outlined in Practice E691 to generate data specific to their materials and laboratory (or between specific laboratories). The principles was followed for the design and analysis of 13.2 through the data; 13.2.3 would then be valid for such data. the details are given in ASTM Research Report RR:D20-1104.)

TABLE 1 Precision Data Total Impact Energy of Plastic Films Using Stainless Steel Darts of Varying Mass

Material	Values expressed in Units of Joules				
	Average	S_r^A	S_R^B	r^C	R^D
Polystyrene	0.094	0.017	0.021	0.047	0.058
Polyethylene	1.162	0.053	0.079	0.150	0.222
Polypropylene	2.575	0.272	0.588	0.761	1.647

^A S_r = within laboratory standard deviation for the indicated material. It is obtained by pooling the within-laboratory standard deviations of the test results from all the participating laboratories $S_r = [((S_1)^2 + (S_2)^2 \dots + (S_n)^2)/n]^{1/2}$

^B S_R = between laboratories reproducibility, expressed as a standard deviation $S_R = [S_r^2 + S_L^2]^{1/2}$

^C r = within-laboratory critical interval between two test results = $2.8 \times S_r$

^D R = between laboratories critical interval between two test results = $2.8 \times S_R$

⁴ Supporting data have been filed at ASTM International Headquarters and may be obtained by requesting Research Report RR:D20-1104.