



Designation: C1127/C1127M – 15 (Reapproved 2023)

# Standard Guide for Use of High Solids Content, Cold Liquid-Applied Elastomeric Waterproofing Membrane with an Integral Wearing Surface<sup>1</sup>

This standard is issued under the fixed designation C1127/C1127M; the number immediately following the designation indicates the year of original adoption or, in the case of revision, the year of last revision. A number in parentheses indicates the year of last reapproval. A superscript epsilon ( $\epsilon$ ) indicates an editorial change since the last revision or reapproval.

## 1. Scope

1.1 This guide describes the design and installation of cold liquid-applied elastomeric waterproofing membrane systems that have an integral wearing surface. The cold liquid-applied elastomeric waterproofing membrane (membrane) to which this guide refers is specified in Specification C957/C957M.

1.2 *Concrete Slab-on-Grade*—Waterproofing the upper surface of a concrete slab-on-grade presents special problems due to the possibility of negative hydrostatic pressure causing loss of bond to the substrate. Consideration of these problems is beyond the scope of this guide. Consult the membrane manufacturer for recommendations when this situation exists.

1.3 The committee having jurisdiction for this guide is not aware of any similar ISO standard.

1.4 The values stated in either SI units or inch-pound units are to be regarded separately as standard. The values stated in each system may not be exact equivalents; therefore, each system shall be used independently of the other. Combining values from the two systems may result in nonconformance with the standard.

1.5 *This standard does not purport to address all of the safety concerns, if any, associated with its use. It is the responsibility of the user of this standard to establish appropriate safety, health, and environmental practices and determine the applicability of regulatory limitations prior to use.* For specific hazard statements, see 15.4.

1.6 *This international standard was developed in accordance with internationally recognized principles on standardization established in the Decision on Principles for the Development of International Standards, Guides and Recommendations issued by the World Trade Organization Technical Barriers to Trade (TBT) Committee.*

<sup>1</sup> This guide is under the jurisdiction of ASTM Committee D08 on Roofing and Waterproofing and is the direct responsibility of Subcommittee D08.25 on Liquid Applied Polymeric Materials Used for Roofing and Waterproofing Membranes that are Directly Exposed to the Weather.

Current edition approved Sept. 1, 2023. Published September 2023. Originally approved in 1989. Last previous edition approved in 2015 as C1127/C1127M – 15. DOI: 10.1520/C1127\_C1127M-15R23.

## 2. Referenced Documents

2.1 *ASTM Standards*:<sup>2</sup>

C33/C33M Specification for Concrete Aggregates

C150/C150M Specification for Portland Cement

C330/C330M Specification for Lightweight Aggregates for Structural Concrete

C332 Specification for Lightweight Aggregates for Insulating Concrete

C717 Terminology of Building Seals and Sealants

C755 Practice for Selection of Water Vapor Retarders for Thermal Insulation

C920 Specification for Elastomeric Joint Sealants

C957/C957M Specification for High-Solids Content, Cold Liquid-Applied Elastomeric Waterproofing Membrane With Integral Wearing Surface

C962 Standards Guide for Use of Elastomeric Joint Sealants (Withdrawn 1992)<sup>3</sup>

C1193 Guide for Use of Joint Sealants

D653 Terminology Relating to Soil, Rock, and Contained Fluids

D1079 Terminology Relating to Roofing and Waterproofing

D1752 Specification for Preformed Sponge Rubber, Cork, and Recycled PVC Expansion Joint Fillers for Concrete Paving and Structural Construction

D2628 Specification for Preformed Polychloroprene Elastomeric Joint Seals for Concrete Pavements

2.2 *U.S. Department of Commerce Standard*:<sup>4</sup>

Product Standard PS 1-74 Construction and Industrial Plywood

2.3 *American Concrete Institute (ACI) Standard*:<sup>5</sup>

301-84 (1985) Specification for Structural Concrete for Buildings

<sup>2</sup> For referenced ASTM standards, visit the ASTM website, [www.astm.org](http://www.astm.org), or contact ASTM Customer Service at [service@astm.org](mailto:service@astm.org). For *Annual Book of ASTM Standards* volume information, refer to the standard's Document Summary page on the ASTM website.

<sup>3</sup> The last approved version of this historical standard is referenced on [www.astm.org](http://www.astm.org).

<sup>4</sup> Available from National Institute of Standards and Technology (NIST), 100 Bureau Dr., Stop 1070, Gaithersburg, MD 20899-1070, <http://www.nist.gov>.

<sup>5</sup> Available from American Concrete Institute (ACI), P.O. Box 9094, Farmington Hills, MI 48333-9094, <http://www.concrete.org>.

2.4 *Steel Structures Painting Council (SSPC) Standards:*<sup>6</sup>  
**Steel Structures Painting Manual, Systems and Specifications:**

**Specification SSPC SP-2 Wire Brush Cleaning**  
**Specification SSPC SP-6 Commercial Blast Cleaning**

2.5 *American Plywood Association (APA) Standard:*<sup>7</sup>  
**APA Plywood Construction Guide**

### 3. Terminology

3.1 *Definitions*—Refer to Terminology **D1079**.

3.2 *Definitions of Terms Specific to This Standard:*

3.2.1 *cold-applied*—capable of being applied without heating as contrasted to hot-applied.

3.2.1.1 *Discussion*—Cold-applied products are furnished in a liquid state, whereas hot-applied products are furnished as solids that must be heated to liquefy them.

3.2.2 *curing time*—the period between application and the time when the material attains its intended physical properties.

3.2.3 *deflection*—the deviation of a structural element from its original shape or plane due to physical loading, temperature gradients, or rotation of its support.

3.2.4 *finish*—the exposed top surface of the plaza deck system, or traffic or wearing surface.

3.2.5 *floated finish*—a concrete finish provided by consolidating and leveling the concrete with only a power-driven or hand float, or both.

3.2.5.1 *Discussion*—A floated finish is more coarse than a troweled finish. For specifications, see ACI Specification 301.

3.2.6 *freeze-thaw cycle*—the freezing and subsequent thawing of a material.

3.2.7 *grout*—concrete containing no coarse aggregate; a thin mortar.

3.2.8 *preparatory coat*—an initial coat of the liquid-applied membrane which is applied at cracks, joints, or terminal points to provide reinforcement to the membrane at these critical areas.

3.2.9 *structural slab*—a horizontal, supporting, cast-in-place concrete building deck.

3.2.10 *traffic surface*—a surface exposed to traffic, either pedestrian or vehicular.

3.2.11 *troweled finish*—a concrete finish provided by smoothing the surface with power-driven or hand trowels, or both, after the float finishing operation.

3.2.11.1 *Discussion*—A troweled finish is smoother than the floated finish. For specifications, see ACI Specification 301.

3.2.12 *wearing surface*—see *traffic surface*.

3.2.13 *wet-film thickness*—the thickness of a liquid coating as it is applied.

3.2.14 *wet-film gauge*—a gauge for measuring the thickness of a wet film.

<sup>6</sup> Available from Society for Protective Coatings (SSPC), 40 24th St., 6th Floor, Pittsburgh, PA 15222-4656, <http://www.sspc.org>.

<sup>7</sup> Available from American Plywood Assoc. (Forest Industries), P.O. Box 11700, Tacoma, WA 98411.

### 4. Significance and Use

4.1 This guide is divided into two sections which provide design and specification guidelines for the use of a cold liquid-applied elastomeric membrane with integral wearing surface for waterproofing building decks in building areas to be occupied by personnel, vehicles, or equipment.

4.2 The intent of Sections 5 – 11, Design Considerations, is to provide information and design guidelines where a waterproofing membrane with integral wearing surface is to be used. The intent of the remaining sections is to provide minimum guide specifications for the use of the purchaser and the seller in contract documents.

4.3 Where the state of the art is such that criteria for a particular condition is not as yet firmly established or has numerous variables that require consideration, reference is made to the applicable portion of Sections 5 – 11 that covers the particular area of concern. Section 16 describes the repair, rehabilitation, and replacement of the membrane.

## DESIGN CONSIDERATIONS

### 5. General

5.1 *Major Components, Subsystems, and Features*—Design of plaza deck waterproofing includes consideration of several subsystems, with their material components and interrelationships. The specific project requirements, types of substrates exposed to weather, difference in climatic conditions to which the deck is exposed, and interior environmental requirements of the occupied space are major determinants in the selection of components. Information needed to design the deck subsystems includes temperature extremes of the inner and outer surfaces, precipitation rates, solar exposure, prevailing wind direction, the pattern and reflectivity of adjacent structures, anticipated amount and intensity of vibration resulting from function or adjacent occupancies, and design live loads.

5.2 *Major Subsystems*—The major subsystems to be considered in waterproofing a building deck are the structural building deck or substrate to be waterproofed, deck supports, traffic-bearing waterproofing membrane, drainage, membrane terminations, and joint systems (see Fig. 1). The design guidelines, as well as the details, components, and drawings which follow, illustrate a principle but are not necessarily the only solutions for a diversity of environments.

5.3 *Compatibility*—Components and contiguous elements should be compatible and coordinated to form a totally integrated waterproofing system.

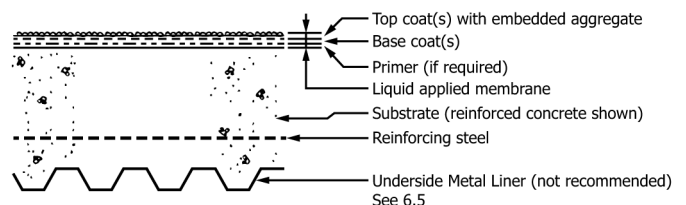

**FIG. 1 Basic Components of Cold-Applied Elastomeric Waterproofing Membrane with Integral Wearing Course (see 5.2 and 5.4)**

**5.4 Waterproofing Membrane**—The waterproofing membrane may be composed of several components, such as substrate primer(s), base coat(s), top coat(s), and antiskid aggregate(s), and each material may be single or multi-component. The thickness of each coat, the use of primers, as well as the type and amount of aggregates needed for each particular application, vary according to the exposure conditions. Areas of high stress and wear, such as sharp turn radii and areas with heavy acceleration and braking from vehicular traffic, require a greater application thickness of the membrane and aggregate than do areas of lower stress. The membrane system must be applied at a thickness great enough to withstand the conditions of use. The actual thickness of each coat required for a particular application and the use of aggregate in top coats should be established between the purchaser and the seller. The purchaser should specify that the minimum membrane or film thickness meets or exceeds the requirements for the particular application and substrate.

**5.5 Membrane Wear**—The liquid-applied elastomeric membrane forms the wearing surface of the building deck and therefore can be expected to show wear and deterioration. The installed membrane system requires maintenance to provide maximum life and waterproofing protection. A program of regularly scheduled inspections (that is, annual, semi-annual, or quarterly) shall be established to detect problems before major damage occurs to the membrane. Small areas of high wear (such as a sharp turn in a parking deck) or areas subjected to abuse can and should be repaired. If the top coat or wearing surface has begun to deteriorate, the wearing surface (including aggregate) can be rehabilitated. Should the membrane system become worn to the point where large areas of the deck substrate are visible, the membrane system probably will have to be completely replaced and structural repairs may be required. Loss of watertight integrity should not be permitted as corrosion of reinforcing steel can occur, causing spalling and thereby jeopardizing the structural integrity of the deck.

## 6. Cast-in-Place Concrete

**6.1 General**—The concrete substrate or building deck referred to in this guide is reinforced, cast-in-place structural concrete, which should conform to all requirements of ACI Specification 301.

**6.2 Strength**—The strength of concrete is an important factor since liquid-applied elastomeric membranes have a much higher modulus and tensile strength than a typical building sealant or a waterproofing membrane normally used with a separate wearing course. (For example, the 100 % (tensile) modulus value may range up to 34.47 MPa [5000 psi].) The concrete must have sufficient strength to avoid rupture at the bond line of the membrane when the membrane is under tensile or shear stress. The strength of concrete is also a factor to be considered insofar as it relates to finish, bond strength, and continuing integrity (absence of cracks and other defects that could affect the integrity of the membrane after installation). Thus, the concrete should have a minimum compressive strength of 20.68 MPa [3000 psi] when the membrane is applied.

**6.3 Aggregates and Moisture Content**—Concrete is a complex mixture of portland cement, water, aggregates and, optionally, admixtures. The portland cement used should be in conformance with Specification **C150/C150M**, Type I or III. (Types II, IV, and V are rarely, if ever, used in building deck construction.) Aggregates generally available for use in concrete are in conformance with Specifications **C33/C33M**, **C330/C330M**, and **C332**. The moisture content of the cured concrete, which is related to the type of aggregate used, can affect the adhesion of the waterproofing membrane to the substrate. With an excessively high moisture content, moisture may condense at the interface of the membrane and concrete, and cause membrane delamination. This is particularly so if the top surface is cooler than the concrete below. Lower moisture contents are achieved with the use of dense stone aggregates conforming to Specification **C33/C33M**, which generally provides structural concrete with a 3 to 5 % moisture content when cured. Aggregates conforming to Specification **C330/C330M** will provide lightweight structural concrete generally having a 5 to 20 % moisture content when cured. Aggregates conforming to Specification **C332** provide lightweight insulating concrete, generally having a relatively low compressive strength and capable of having over 20 % moisture content when cured. The concrete used for the deck substrate should have a maximum moisture content of 8 % when cured and a minimum density of 1760 kg/m<sup>3</sup> [110 lb/ft<sup>3</sup>]. Hence, a limited number of lightweight aggregates (Specification **C330/C330M**) may be used, and no lightweight insulating aggregates (Specification **C332**) shall be used.

**6.4 Admixtures, Additives, and Cement/Concrete Modifiers**—Admixtures, additives, and modifiers serve many functions in mixing, forming, and curing concrete, such as to retard or accelerate the cure rate; reduce the water content required; entrain air; increase strength; create or improve the ability of the concrete to bond to existing, cured concrete; permit thin topping overlays; and improve workability. Some admixtures and modifiers (particularly polymeric, latex, or other organic/chemical based materials) may coat the concrete particles and reduce the ability of the waterproofing membrane to bond to the concrete. The membrane manufacturer should be consulted if the concrete used for the deck contains any admixtures, additives, or modifiers in order to determine the compatibility of the membrane with the concrete.

**6.5 Underside Metal Liner and Coating**—The underside of the concrete deck should not be impervious to water, but rather should permit the free evaporation of water from the concrete. If an underside metal liner, used as a form or composite structural component, does not permit moisture to evaporate, water vapor may be trapped between the membrane and the support and condense at the membrane-concrete interface. The condensate can destroy or prevent the adhesive bond of the membrane to the concrete. Adequate drying of residual moisture in concrete poured over permanent metal liners requires a much longer period (possibly years) to achieve similar moisture content as is achieved with slabs stripped of forming. Uniformly spaced perforations in permanent metal liners may provide a solution to the vapor barrier problem, but as yet there are no definite data on the requirements for the size and spacing



of the perforations. Subsequent coating which might inhibit moisture vapor transmission through the vents should be avoided. Coating the underside of a stripped concrete deck with a coating that inhibits vapor transmissions should also be avoided. The minimum perm rating permissible for such a coating to be acceptable is 1 metric perm [1.52 U.S. perms].

6.5.1 *Perforations*—Perforated metal liners have different structural characteristics and properties than nonperforated material. These differences must be recognized and accommodated in the design and use of these materials.

6.6 *Slope for Drainage*—Drainage at the membrane level is important. Since the waterproofing membrane is placed directly on the concrete slab, a monolithic concrete substrate slope of a minimum 11 mm/m [ $1/8$  in./ft] should be maintained. Slope is best achieved with a monolithic pour, as compared with a separate concrete fill. The fill presents the potential of additional cracks and provides a cleavage plane between the fill and the structural slab. The cleavage plane complicates the detection of leakage in the event that water penetrates the membrane at a crack in the fill and travels along the separation until reaching a crack in the structural slab.

6.7 *Finish*—The structural slab should have a finish that facilitates proper application of the liquid-applied membrane. The surface should be of sufficiently rough texture to provide a mechanical bond for the membrane, but not so rough as to preclude achieving continuity of the membrane of the specified thickness across the surface. As a minimum, ACI Specification 301 floated finish is required with ACI Specification 301 troweled finish preferred, deleting the final trowelling. Follow the requirements of the membrane manufacturer as to the required finish.

6.7.1 *Vertical Substrate*—The vertical surface to which the waterproofing membrane is adhered should have a sound, smooth finish, dry and free from cracks and loose materials, as stated for the horizontal or deck substrate.

6.8 *Curing*—Curing of the structural slab is necessary to provide a sound concrete surface and obtain the quality of concrete required. Curing is a chemical reaction accomplished with moisture and should not be misconstrued as drying. The concrete should be cured a minimum of seven days and aged a minimum of 28 days, including curing time, before applying the liquid-applied membrane. The more commonly known curing methods are moist curing, impermeable sheet curing, and chemical curing.

6.8.1 *Moist Curing*—Moist curing is achieved by keeping the surfaces continuously wet by covering them with burlap saturated with water and kept wet by spraying or hosing. The covering material should be placed in a manner that provides complete surface coverage, with joints lapped a minimum of 75 mm [3 in.].

6.8.2 *Sheet Curing*—Sheet curing is accomplished with a sheet vapor barrier, which reduces the loss of water from the concrete and moistens the surface of the concrete by condensation, thus preventing the surface from drying while curing. Laps of sheets covering the slab should not be less than 5 cm [2 in.] and should be sealed or weighted. (See Practice C755.)

6.8.3 *Chemical Curing*—Liquid or chemical curing compounds should not be used unless approved by the manufacturer of the liquid-applied membrane, as the material may interfere with the bond of the membrane to the structural slab.

6.9 *Dryness*—Membrane manufacturers' requirements for substrate dryness vary from being visibly dry to having a specific maximum moisture content as measured by a moisture meter. Since there is a lack of unanimity in this regard, it is necessary to meet the manufacturer's requirements for the particular membrane being applied.

6.10 *Joints*—Joints in a structural concrete slab are herein referred to as reinforced joints, nonreinforced joints, and expansion joints, as follows:

6.10.1 *Reinforced Joints*—Reinforced joints consist of hair-line cracks, cold joints, construction joints, and control joints held together with reinforcing steel bars or wire fabric. These are considered static joints with little or no movement anticipated because the slab reinforcement is continuous across the joint.

6.10.2 *Nonreinforced Joints*—Nonreinforced joints consist of cracks or butted construction joints and isolation joints not held together with reinforcing steel bars or wire fabric. These joints are generally considered by the designer of the structural system as nonmoving or static joints. However, they should be considered as capable of having some movement, the magnitude of which is difficult to predict.

6.10.3 *Expansion and Seismic Joints*:

6.10.3.1 Expansion joints, as differentiated from control joints, are designed to accommodate movement in more than one direction, are an integral part of the building structural system, and are to be carried through the entire structure. Expansion joints are incorporated in the structural frame to reduce internal stresses caused by wide temperature ranges, or differential movement, or both, between structural elements, as might be the case in large adjoining heated and unheated spaces; where there are different foundation settlement conditions between adjacent elements; or where movements between high and low attached structures are anticipated.

6.10.3.2 Seismic joints are a special case in which the joints are generally quite large and are designed to limit damage to the structural frame during earthquakes.

6.10.3.3 Expansion and seismic joints are best located at the high points of contoured substrates to deflect water away from the joint. For expansion joints designed for thermal movement only, the movement is expected to be only in the horizontal plane. Seismic joints are designed to accommodate both vertical and horizontal movement. In detailing expansion joints to achieve watertightness, the amount of movement anticipated should be carefully determined using a reasonable factor of safety. The opening size and configuration should then be related to the capability of the joint seal materials so as to accommodate the anticipated movement.

6.10.4 *Joint Design Using Cold, Liquid-Applied Elastomeric Joint Sealants*—The guidelines provided in Guide C962 should be followed for the joint size and configuration needed to accommodate the anticipated joint movement. Joint

preparation, backup material requirements, and sealant type should also conform to the requirements detailed in Guide C962.

6.10.5 *Joint Design Using Compression Seals*—Compression seals are designed to be continuously under compression through the entire joint movement range. There are two main types of joint designs: (1) those which use a steel angle cap at the face and surface of the joint, and (2) those which use a curve or bevel in the concrete at the top edge of the joint face. The use of a beveled or curved face on the concrete is not recommended because of the difficulty of maintaining a uniform coating of the liquid-applied membrane on a curved or beveled surface, the possible compatibility problems between the membrane and the compression seal and its lubricant/adhesive, and water ponding in the recessed surface of the compression seal. Since there is no uniform recommended practice for the design and installation of compression seal expansion joints, the compression seal manufacturer should be contacted for joint design and installation guidelines. All compression seal materials used should meet the requirements of Specification D2628.

## 7. Precast Concrete Decks

7.1 *General*—The application of liquid-applied elastomeric membranes directly to structural precast concrete decks is not recommended. Such decks, which consist of numerous individual units or panels, can have problems in many areas. Among these problems are unsuitable surface finish of the individual panels, maintenance of uniformity in level and proper slope during installation, uniform joint spacing, and installation, coverage, and protection of the shear connectors. The individual planks are subject to differential movement (vertically and horizontally) at the panel joint, which could overstress a membrane and lead to premature failure if the membrane was carried across the joint. A poured-in-place, reinforced concrete topping slab applied over a precast concrete deck may be a suitable substrate for the liquid-applied membrane under certain conditions. It can provide the finish and slope uniformity necessary for proper drainage and geometry at control joints. Shear connectors should be used to limit movement at joints (except at expansion joints). The topping slab should be bonded to the precast units and the control joints centered over the precast unit joints.

7.2 *Topping Slab*—The topping slab should be of a minimum thickness to meet the design requirements and should conform to the requirements of 6.1 – 6.4.

7.2.1 *Topping Slab Reinforcement*—The topping slab should be reinforced with metal mesh or bars to reduce the possibility of crack growth and to control the differential movement (horizontal and vertical shear) in the control joints.

7.3 *Control Joints*—A control joint should be placed above each junction where two precast units are butted together. The joint should be a minimum of 13 mm [ $\frac{1}{2}$  in.] wide and 25 mm [1 in.] deep.

7.4 *Topping Slab Treatment*—The topping slab should conform to the requirements of Section 6 in all respects of slope, drainage, finish, curing, dryness, and joint design.

## 8. Plywood Substrate

8.1 *General*—Plywood decks are normally used only in pedestrian applications, such as walkways and balconies, where light to moderate loads are expected.

8.2 *Grade*—All plywood should be identified as conforming to PS 1 for construction and industrial plywood by the grade, trademarks of the American Plywood Association, or equivalent. For maximum smoothness, EXT Type APA, Grade A-C should be used. The “A” side should be positioned to receive the coating.

8.3 *Placement*—Select plywood thickness and attachment methods as indicated in the APA Plywood Construction Guide and other APA literature, using only nonrusting screw, spiral, or coated nail-type fasteners. An option would be to recess or countersink fasteners  $\frac{1}{8}$  to  $\frac{1}{4}$  in. and seal with a compatible sealant. Suitable edge support to prevent differential deflection between panels should be provided. Panel edges should be tongue and groove or supported on solid blocking. Space panels 3 to 5 mm [ $\frac{1}{8}$  to  $\frac{3}{16}$  in.] at panel ends. The space directly below the plywood should be vented to the exterior and below the vented space should be a vapor barrier over occupied space or damp areas to maintain as dry a condition as possible for the plywood and its supports.

8.4 *Finish*—The finish of the plywood should be consistent with the grade according to PS 1.

### 8.5 *Joint Treatment:*

8.5.1 *Panel Spacing Joints*—Joints between plywood panels should be filled flush with a sealant compatible with the coating system, as recommended by the coating manufacturer. Prior to installing the sealant, the joints should be dry and swept or blown clean of dust, dirt, and debris.

8.5.2 *Expansion Joints*—Expansion joints are not necessary in plywood decks unless required because of other factors in the building construction. If such joints exist in the building structure, the membrane should be terminated on either side of the joint, but in such a manner as to provide a watertight seal at the joint interface.

## 9. Incidental Substrates

9.1 *General*—All incidental substrates such as metal, plastic, and coated materials should be cast-in-place or otherwise firmly anchored to prevent any horizontal shear of the membrane. Joints at edges of any substrate that is not firmly anchored should be treated as expansion joints terminating on the deck substrate.

9.2 *Patching, Leveling, and Topping Compounds*—Patching, leveling, and topping compounds are used to repair concrete decks and provide proper slope and finish to the deck. Some compounds, particularly those containing polymeric, latex, or other organic chemical materials, may have poor adhesion with the membrane. The membrane manufacturer should be consulted to determine the compatibility of these compounds with the membrane. Patching, leveling, and topping compounds, when used, must be well cured and meet the dryness tests in 6.3 and 6.9.

## 10. Membrane

10.1 *General*—A liquid-applied waterproofing membrane has the capability of adhering to the substrate and should be applied so as to take optimum advantage of this inherent characteristic. Without this adhesion, a waterproofing membrane with integral wearing surface could be torn loose with even the lightest traffic, leading rapidly to complete membrane failure. Water vapor that condenses at the membrane-concrete interface, or water diffusing through the membrane, can act at the interface to destroy the adhesion of the membrane to the concrete.

10.1.1 The detection of leakage in a building deck waterproofing system could be a significant problem when the waterproofing membrane is not bonded to the structural slab. Water penetrating an unbonded membrane could migrate laterally under the membrane until reaching a crack or defect in the structural slab and then leak through to the space below. Leakage through the slab, therefore, would not necessarily indicate the location of the water entry in the membrane above.

10.1.2 Systems that meet the requirements of Specification C957/C957M could be expected to bridge reinforced hairline cracks that develop after the undersurface is laid. The systems are not designed to bridge dynamic, unreinforced cracks that develop under the membrane.

### 10.2 Surface Preparation:

10.2.1 *Concrete Surface Preparation*—Concrete surfaces should be prepared according to the membrane manufacturer's recommendations to remove laitance and other unwanted matter. Such preparation may include either an acid etch or mechanical abrasion (such as sand blast, water blast, scarifying, or grinding) or a combination of mechanical abrasion followed by an acid etch. Note the chloride ions that result when muriatic (hydrochloric) acid is used, as the acid may contribute to chloride-ion induced corrosion of the reinforcing steel. The concrete must be thoroughly rinsed and allowed to dry before starting any preparatory work.

10.2.2 *Plywood Surface Preparation*—The wood surface should be cleaned of all dirt, dust, and debris by sweeping or by an air blast. All contaminants should be removed. Washing the plywood surface with detergent and water is not recommended. The absorbed moisture can cause poor adhesion and form bubbles and blisters if the membrane is applied to a moist deck, and any detergent film remaining on the deck may cause poor adhesion of the membrane.

10.2.3 *Metal Surface Preparation*—Remove any weld slag, flux, and burrs and grind welds smooth. Clean to a bright metal finish with power wire brush in accordance with SSPC SP 2, or preferably sand blast to an SSPC SP-6 finish. Do not burnish the substrate. Coat with a primer or an anticorrosion finish followed by a primer as soon as possible. The metal should be coated before any rust bloom forms.

10.2.4 *Plastics, Paints, and Other Coatings*—Wipe the substrate with the solvent or cleaning solution specified by the membrane manufacturer until all contamination has been removed. Apply the primer according to the manufacturer's requirements.

10.2.5 *Cleaning Substrates*—All dust, dirt, and any type of contamination should be removed by air blast, vacuuming, or

sweeping. Contamination from oil or similar materials should be removed from the substrate. If an air blast is used, caution should be taken to prevent oil or water from the air compressor from getting into the air line and contaminating the substrates.

10.2.6 *Primers*—When required by the membrane manufacturer, each substrate should be primed with the primer specified by the membrane manufacturer for that substrate (steel, iron, brass, aluminum, metal, wood, concrete, plastic, coating, etc.) and allowed to dry as specified.

10.3 *Application*—The membrane should be applied under dry, frost-free conditions. The frost-free condition should exist throughout the depth of the concrete slab, and not simply on the surface. Membrane manufacturers' requirements for substrate dryness are described in 6.9. Excessive moisture in the substrate (see 6.3 and 6.5) or moisture on the surface (see 6.9) (as from frost or rain) may result in a membrane that has an improper cure with excessive gas pockets being formed, has little or no adhesion to the substrate, and may give poor service. In case rain or snow interrupts the application after at least one coat of material has been applied, the membrane manufacturer's directions should be followed pertaining to any necessary treatment of the cured, already applied material before continuing the application process.

10.4 *Terminal Conditions*—Four locations where a liquid-applied membrane is normally terminated or interrupted are on walls, at drains, at penetrations, and at expansion joints. The important consideration at terminal conditions is to prevent water from penetrating the substrate or behind the membrane at its edge.

10.4.1 *Termination on Walls or Other Vertical Surfaces*—The membrane should be turned up at vertical surfaces to eliminate the possibility of ponded surface water penetrating the wall above the membrane and running down behind it into the building. The minimum safe height of such a termination is dictated by the opportunity for conditions such as ponding and drifting snow that may be presented by the building's geometry and environment. The membrane may be continued farther up the wall for aesthetic reasons. The aggregate is rarely continued up the wall. The possibility of water entering through joints or cracks in the surface of the wall behind the coated surface must be examined. Water entering behind the coated surface is held by the membrane and consequently acts to destroy the adhesive bond between the membrane and the wall. Where this possibility exists (as determined by the building's geometry and environment), waterproof the opposite surface or devise a way for the water to get out without getting under the deck coating membrane.

10.4.1.1 *Deck to Vertical Surface Dynamic Joints*—Any junction of the horizontal deck and a vertical surface that is capable of movement greater than 3.2 mm [0.125 in.] in any direction should be treated as an expansion joint, in accordance with 6.10.3. Junctions that move less than 3.2 mm [0.125 in.] should be treated in accordance with 14.6.1.

10.4.2 *Termination at Drains*—Drains should be designed with a 50 mm [2 in.] wide (minimum) flange as an integral part. The drain should be cast in the slab when the deck is placed with the top of the flange set flush with or slightly below the surface of the slab. The wide flange provides a termination



point for the liquid-applied membrane without endangering the function of the membrane or the drain.

10.4.3 *Termination at Penetrations*—Penetrations or protrusions into or through the surface by such items as conduits or service pipes create critical problems and should be avoided wherever possible. Such critical locations are best treated by casting a pipe sleeve into the structural slab (see Fig. 2). Such a sleeve may be cast in the deck during the main pour, or may be boxed out and cast at a later date.

10.4.3.1 A second method involves cutting a core hole in the deck and putting a sleeve having a wide flange into the hole. It is more difficult to maintain a waterproof seal using this second type of sleeve and is the least preferred method (see Fig. 3).

10.4.4 *Treatment at Joints*—Joints in the structural slab should be treated as follows, depending on whether they are reinforced joints, nonreinforced joints, or expansion joints:

10.4.4.1 *Treatment of Reinforced Joints or Cracks*—Fig. 4 indicates one recommended treatment of reinforced concrete joints in the structural slab. The designer should realize that the elongation capacity of this type of detail is quite limited and implicitly relies on the membrane’s crack-bridging ability to withstand the strains imposed by the opening of cracks and reinforced joints. Alternatively, prevent the membrane from adhering to the substrate for a finite width centered on the joint or crack by employing a properly designed compatible bond-breaker tape.

10.4.4.2 *Treatment at Nonreinforced Joints*—Nonreinforced joints that are in reality nonmoving could be treated in the same manner as reinforced joints. However, since the joints are not held together with reinforcing steel, some movement, however slight, should be anticipated and provided for since the liquid-applied membrane has limited ability to take movement. Nonreinforced joints could open due to such factors as shrinkage, creep, and thermal contraction. Fig. 5 shows a nonreinforced butted joint that is capable of expanding 3.2 mm [ $\frac{1}{8}$  in.], the minimum that should be provided for when using a sealant capable of  $\pm 25\%$  movement. The minimum sealant width should be correspondingly wider with a sealant having lesser movement capability. If the designer of the structural system feels that greater movement than 3.2 mm [ $\frac{1}{8}$  in.] could occur in such joints, they should be treated as expansion joints.

10.4.4.3 *Treatment of Expansion Joints*—Expansion joints are designed to accommodate a predetermined amount of movement. Such movement could be due to thermal change, shrinkage, creep, deflection, or other factors and combinations

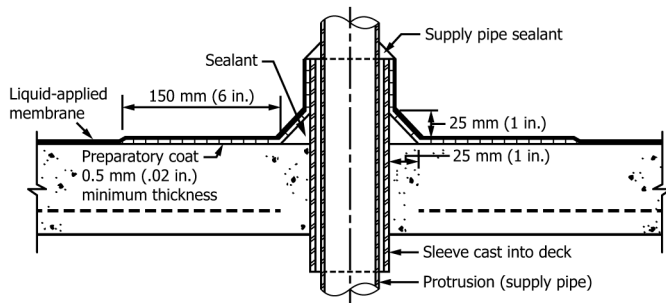

FIG. 2 Termination at Cast-in-Place Sleeve (Protrusion Installed) (see 10.4.3, 14.6.3.1, 14.6.3.2, and 14.6.3.4)

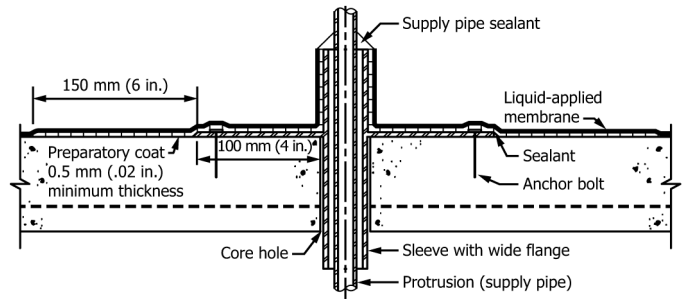
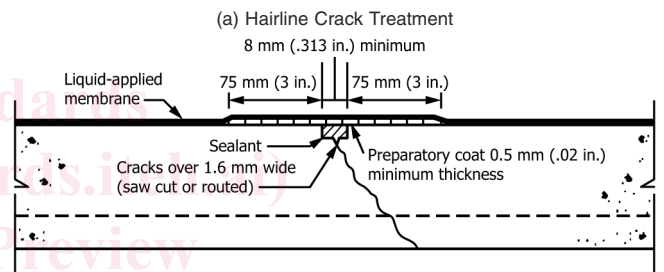
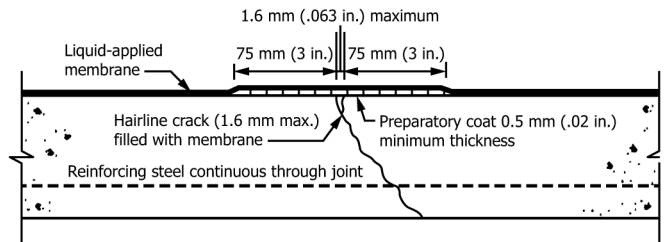

FIG. 3 Termination at a Core-Drilled Sleeve Having a Wide Flange (see 10.4.3, 14.6.3.3, and 14.6.3.4)



(b) Treatment of Cracks Wider than 1.6 mm [0.063 in.]

FIG. 4 Treatment of Reinforced Cracks and Joints (see 10.4.4.1, 14.5.1, and 14.5.2)

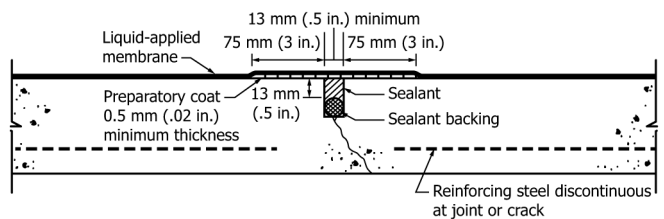

FIG. 5 Treatment of Nonreinforced Cracks and Joints (see 10.4.4.2 and 14.5.3)

of factors. Because waterproofing membranes with integral wearing surfaces generally have limited elongation capacity, they should not be continued over an expansion joint. Rather, the membrane should terminate on either side of the expansion joint. Thus, the design of the expansion joint can be made separate from the design of the waterproofing membrane except that the base coat or top coat of the membrane must be applied over any metal flashing or flanges used in the design of the expansion joint. A gutter system may be provided under the expansion joint for a secondary line of defense against leakage.