



Designation: D2132 – 23

# Standard Test Method for Dust-and-Fog Tracking and Erosion Resistance of Electrical Insulating Materials<sup>1</sup>

This standard is issued under the fixed designation D2132; the number immediately following the designation indicates the year of original adoption or, in the case of revision, the year of last revision. A number in parentheses indicates the year of last reappraisal. A superscript epsilon ( $\epsilon$ ) indicates an editorial change since the last revision or reappraisal.

## 1. Scope\*

1.1 This test method is intended to differentiate solid electrical insulating materials with respect to their resistance to the action of electric arcs produced by conduction through surface films of a specified contaminant containing moisture. Test Methods [D2302](#), [D2303](#), [D3638](#), and [D5288](#) are also useful to evaluate materials.

1.2 *Units*—The values stated in SI units are the standard. The inch-pound units in parentheses are for information only. The values stated in each system are not necessarily exact equivalents; therefore, to ensure conformance with the standard, each system shall be used independently of the other, and values from the two systems shall not be combined.

1.3 *This standard does not purport to address all of the safety concerns, if any, associated with its use. It is the responsibility of the user of this standard to establish appropriate safety, health, and environmental practices and determine the applicability of regulatory limitations prior to use.*

NOTE 1—There is no equivalent ISO standard.

1.4 *This international standard was developed in accordance with internationally recognized principles on standardization established in the Decision on Principles for the Development of International Standards, Guides and Recommendations issued by the World Trade Organization Technical Barriers to Trade (TBT) Committee.*

## 2. Referenced Documents

2.1 *ASTM Standards:*<sup>2</sup>

- [D709 Specification for Laminated Thermosetting Materials](#)
- [D1711 Terminology Relating to Electrical Insulation](#)
- [D2302 Method of Test for Differential Wet Tracking Resis-](#)

<sup>1</sup> This test method is under the jurisdiction of ASTM Committee [D09](#) on Electrical and Electronic Insulating Materials and is the direct responsibility of Subcommittee [D09.07](#) on Electrical Insulating Materials.

Current edition approved Aug. 1, 2023. Published September 2023. Originally approved in 1962. Last previous edition approved in 2019 as D2132 – 19. DOI: 10.1520/D2132-23.

<sup>2</sup> For referenced ASTM standards, visit the ASTM website, [www.astm.org](http://www.astm.org), or contact ASTM Customer Service at [service@astm.org](mailto:service@astm.org). For *Annual Book of ASTM Standards* volume information, refer to the standard's Document Summary page on the ASTM website.

[tance of Electrical Insulating Materials with Controlled Water-to-Metal Discharges \(Withdrawn 1982\)](#)<sup>3</sup>

[D2303 Test Methods for Liquid-Contaminant, Inclined-Plane Tracking and Erosion of Insulating Materials](#)

[D3638 Test Method for Comparative Tracking Index of Electrical Insulating Materials](#)

[D5288 Test Method for Determining Tracking Index of Electrical Insulating Materials Using Various Electrode Materials \(Excluding Platinum\)](#)

## 3. Terminology

3.1 *Definitions:*

3.1.1 For definitions pertinent to this test method see Terminology [D1711](#).

## 4. High Voltage Hazard

4.1 **Warning**—Lethal voltages are a potential hazard during the performance of this test. It is essential that the test apparatus, and all associated equipment electrically connected to it, be properly designed and installed for safe operation.

4.2 Solidly ground all electrically conductive parts which it is possible for a person to contact during the test.

4.3 Provide means for use at the completion of any test to ground any parts which were at high voltage during the test or have the potential for acquiring an induced charge during the test or retaining a charge even after disconnection of the voltage source.

4.4 Thoroughly instruct all operators as to the correct procedures for performing tests safely.

4.5 When making high voltage tests, particularly in compressed gas or in oil, it is possible for the energy released at breakdown to be sufficient to result in fire, explosion, or rupture of the test chamber. Design test equipment, test chambers, and test specimens so as to minimize the possibility of such occurrences and to eliminate the possibility of personal injury.

NOTE 2—If the potential for fire exists, have fire suppression equipment available.

<sup>3</sup> The last approved version of this historical standard is referenced on [www.astm.org](http://www.astm.org).

\*A Summary of Changes section appears at the end of this standard

5. Summary of Test Method

5.1 With electrodes mounted as shown in Fig. 1, coat test specimens with a synthetic dust and test in a chamber shown in Fig. 2. Using the fog nozzle, direct a water spray at the test specimen. After the surface has been wetted, apply a 60 Hz voltage between the electrodes. Arcing occurs across localized high-resistance areas produced by nonuniform evaporation of the water from the contaminant. These arcs produce high temperatures in the underlying insulation with resultant carbonization of most organic materials. The carbonization concentrates the electric field. It is possible further carbonization will occur in the direction of the field. In such cases, a carbon track is formed which spans the distance between the electrodes and causes failure. It is possible that materials that do not track will erode under the action of the arcing. Such erosion usually progresses from an upper electrode through the thickness of the specimen towards the underlying electrode.

5.2 Rate materials that track in terms of the time required to form a track between the electrodes.

5.3 Rate materials that do not track in terms of the time required to erode to failure.

5.4 Failure will be indicated when the current increases sufficiently to actuate an overcurrent device.

NOTE 3—The conditions of this test favor the formation of a track for several possible reasons. Most important, the continuous renewal of the conducting properties of the contaminant by the water spray allows a track to grow progressively over long periods of time.

6. Significance and Use

6.1 Method—It is possible that electrical insulation in service will fail as a result of tracking, erosion, or a combination

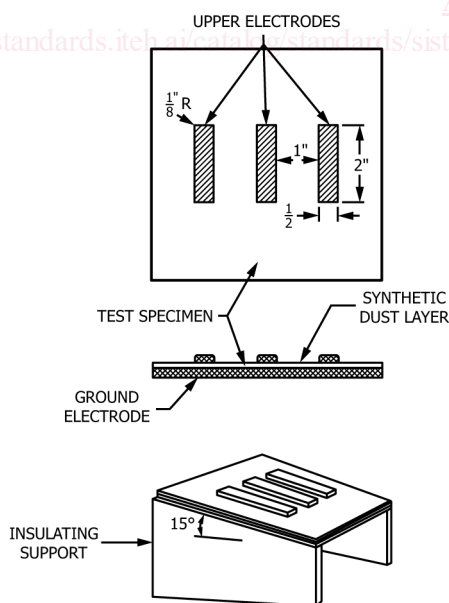

Metric Equivalents

in.	1/8	1/2	1	2
mm	3.2	12.7	25.4	50.8

FIG. 1 Test Arrangement of Electrode System

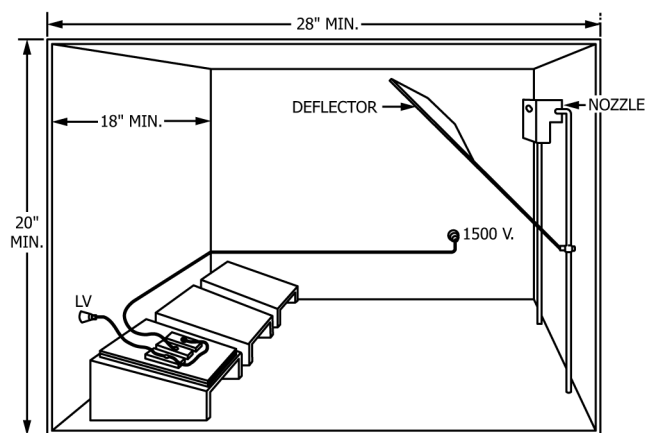

460 mm = 18 in. 510 mm = 20 in. 710 mm = 28 in.

FIG. 2 Dust and Fog Test Chamber, Minimum Recommended Size

of both, if exposed to high relative humidity and contamination environments. This is particularly true of organic insulations in outdoor applications where the surface of the insulation becomes contaminated by deposits of moisture and dirt, for example, coal dust or salt spray. This test method is an accelerated test that simulates extremely severe outdoor contamination. It is believed that the most severe conditions likely to be encountered in outdoor service in the United States will be relatively mild compared to the conditions specified in this test method.

6.2 Test Results—Materials can be classified by this test method as tracking-resistant, tracking-affected, or tracking-susceptible. The exact test values for these categories as they apply to specific uses will be specified in the appropriate material specifications, but guideline figures are suggested in Note 4. Tracking-resistant materials, unless erosion failure occurs first, have the potential to last many hundreds of hours (Note 5). Erosion, though it is possible that it will progress laterally, generally results in a failure perpendicular to the specimen surface. Therefore, compare only specimens of the same nominal thickness for resistance to tracking-induced erosion. Estimate the extent of erosion from measurements of the depth of penetration of the erosion. Place materials that are not tracking-susceptible in three broad categories—erosion-resistant, erosion-affected, and erosion-susceptible. When the standard thickness specimen is tested, the following times to failure typify the categories (Note 6):

Erosion-susceptible	5 h to 50 h
Erosion-affected	50 h to 200 h
Erosion-resistant	over 200 h

NOTE 4—Tracking-susceptible materials usually fail within 5 h. Tracking-affected materials usually fail before about 100 h.

NOTE 5—This information is derived from the individual experiences of eight laboratories using this test method since its publication as a suggested test method in June 1957, and from the results of an organized test program among these laboratories.

NOTE 6—In a normal distribution approximately 68 % of all test values are included within ±1 standard deviation of the mean.

6.3 Interpretation of Test Results—This test method provides information that allows classification as described in 6.2. The comparison of materials within the same group is likely to

be ambiguous unless three or more replicate specimens are tested. When the test method is used for specification purposes, do not establish simple minimum values without consideration of the large variance to be expected in test results. It is recommended that quality levels and specification minima be determined by statistical techniques.

### 7. Apparatus

7.1 *General*—A schematic diagram of the power supply and control apparatus for testing one specimen is shown in Fig. 3(a). It is generally desirable to test three or more specimens simultaneously. It is recommended but not mandatory that a separate power supply and control be used for each test specimen. This allows “breaking-in” and recording of time to failure separately for each specimen.

7.2 *Circuit Breaker*—The circuit breaker (current relay, *OL*) interrupts the power supply on failure and stops the timing meter. Use it as an ON-OFF switch and as a device for interrupting air and water supply when all specimens fail. Fig. 3(b) illustrates the air and water supply circuit when three specimens are tested using one fog nozzle. The circuit breaker shall be rated at 2 A to 3 A, inverse-time element type, for a 115 V supply. Use a resistance,  $R_0$ , to shunt the current coil during the break-in period so that the breaker will not actuate as a result of the bright-flash currents typical of this period. Adjust the resistance to produce an effective breaker action at approximately 6 A (115 V supply). Remove or switch out the shunt resistance after break-in.

7.3 *Supply Transformer*<sup>4</sup>—Use a supply transformer,  $T_2$ , capable of supplying 1500 V, 60 Hz, rms. A 200 VA potential transformer is capable of supplying power for up to three specimens if desired. Use a transformer with a 20:1 ratio when used with a 115 V primary supply. Choose a transformer that offers an impedance between 600  $\Omega$  and 1200  $\Omega$  resistance and 200  $\Omega$  and 700  $\Omega$  reactance. Accomplish this by insertion of inductance  $L$  and resistance  $R_1$  in the low-voltage side and resistance  $R_2$  in the high-voltage side.

<sup>4</sup> General Electric Type JE41, Model KAR-3, and Westinghouse Type VS, Style No. 687588, have been found satisfactory for this purpose.

7.4 *Control Transformer*—Use a variable-ratio autotransformer,  $T_1$ , to adjust the voltage as required.

7.5 *Voltmeter*—Use a voltmeter,  $V$ , in the primary side to determine the specimen test voltage. Alternatively, use a high-impedance voltmeter for connection in the secondary, in which case take precautions to prevent electric shock to an operator. If a voltmeter is used in the primary, calibrate it against secondary voltage with a secondary load of 10 mA.

7.6 *Monitoring Provisions*—Use an ac ammeter,  $A$ , to monitor specimen current. Use a separate ammeter for each test specimen. Alternatively make provisions to connect an ammeter into each test-specimen circuit. Shunt the ammeter with a normally closed contact,  $PB$ , and a capacitance,  $C$ , to protect the ammeter from the large intermittent currents that occur during break-in. Connect the capacitance, if used, by a switch,  $S_A$ . After the break-in period, open the switch unless the values of the capacitance and ammeter impedances are such as to produce negligible error in current measurement. Use terminals  $A$ ,  $B$  and  $C$ ,  $D$  for oscilloscope monitoring, for current measurement with a voltmeter in combination with a resistor, or for insertion of an undercurrent relay to be used to stop the clock if the scintillation current falls below the specified value.

7.7 *Electrodes*—Use three copper or brass electrodes 13 mm by 51 mm by 3.2 mm (0.5 in. by 2 in. by 0.125 in.), with corners rounded to a 3.2 mm (0.125 in.) radius on the top surface of the specimen and spaced 25 mm (1 in.) apart as shown in Fig. 1. Use a ground plate of copper or brass and of the same size as the test specimen on the bottom surface and mounted on an insulating support inclined 15 deg to the horizontal as shown in Fig. 1. Clamp the electrodes firmly to the test specimen. A suggested arrangement is shown in Fig. 4.

7.8 *Test Chamber*—Use a cubicle test chamber, Fig. 2, made from plastic or metal. The front wall is made of glass or poly(methyl methacrylate), or contains viewing ports or doors made of these materials. Make the cubicle at least 510 mm (20 in.) high and 710 mm (28 in.) wide. Determine the depth by the number of specimens to be tested. Three specimens require a minimum depth of 460 mm (18 in.). Fit the chamber with means for venting near the bottom of the cubicle, preferably along the end of the chamber where the specimens are located. Limit the venting area to about 130 cm<sup>2</sup> (20 in.<sup>2</sup>) to eliminate dependence of test results on the ambient humidity.

7.8.1 Mount one or more fog nozzles (Fig. 5) to obtain the specified uniform moisture deposition on all test specimens. It is suggested that one fog nozzle, mounted approximately 635 mm (25 in.) straight line distance from the nozzle to the center specimen at a height of approximately 355 mm (14 in.) above these specimens, will, with a suitably adjusted deflector, produce the specified conditions for three test specimens in a single cubicle (see Fig. 2). When only one fog nozzle is used in the cubicle, it is recommended that additional air be introduced into the cubicle equal to about double that flowing through a standard fog nozzle connected to an air supply of 0.035 MPa to 0.04 MPa (5 psig to 6 psig).

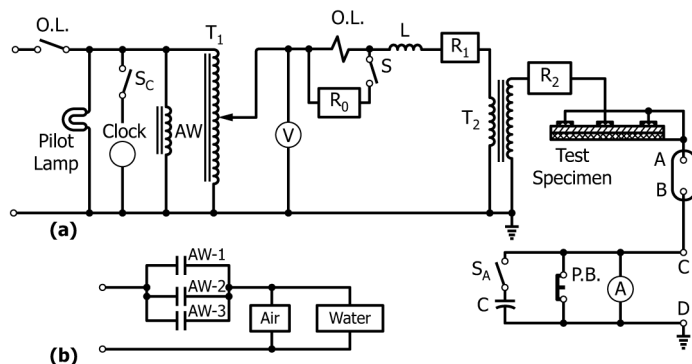

(a) Power supply and control circuit of wet tracking tests.  
(b) Air and water supply circuit.

FIG. 3 Circuit Diagrams

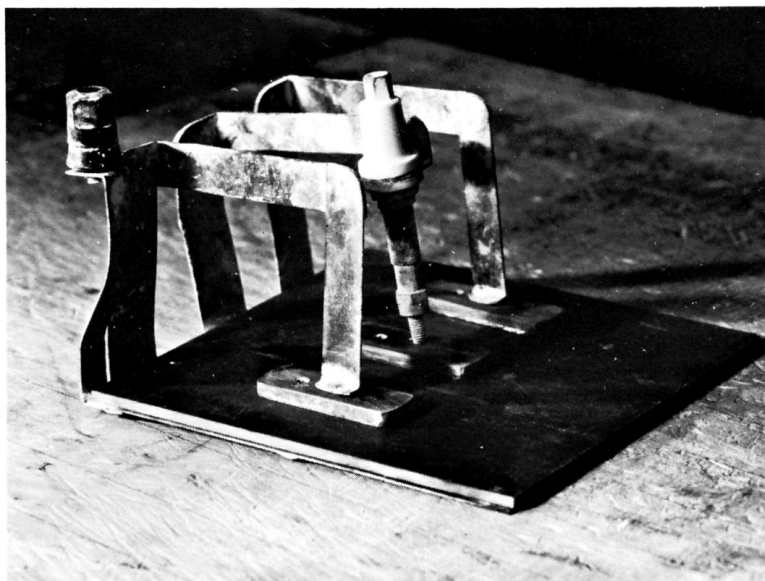
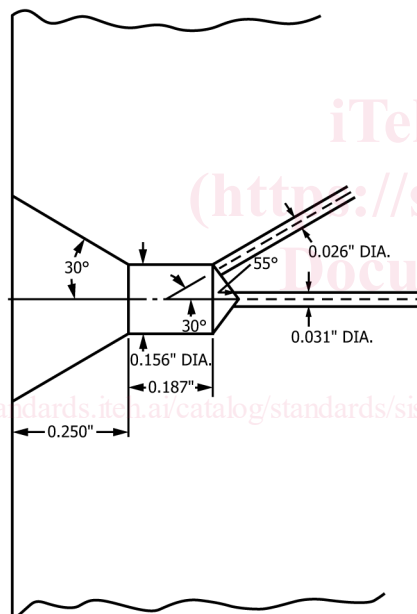

FIG. 4 Clamping Arrangement for Test-Specimen Electrodes



	Metric Equivalents				
in.	0.026	0.031	0.156	0.187	0.25
mm	0.66	0.79	3.96	4.75	6.35

FIG. 5 Orifices of Fog Nozzle

7.8.2 Connect the fog nozzle assembly,<sup>5</sup> Fig. 6, to an air and water supply. Provide means to adjust the air supply to 0.035 MPa to 0.04 MPa (5 psig to 6 psig). Supply the water from a reservoir mounted below the nozzle so that the water level is approximately 125 mm (5 in.) below the nozzle. Use a needle valve in the water line to the nozzle to control the rate

<sup>5</sup> A suitable fog nozzle is a Lucite atomizer, Model 145-718 manufactured by Industrial Filter and Pump Manufacturing Co., 5916 Ogden Ave., Chicago, IL 60650.(708-656-7800)

of fog deposition. To ensure uninterrupted flow of the water to the nozzle, filter the water to remove the dissolved air in the water.

## 8. Artificial Contaminant

8.1 Use synthetic dust of the following composition:

Material	Parts by Weight
Fling (SiO <sub>2</sub> floated), <sup>A</sup> 240-mesh	85
Clay, 325-mesh <sup>B</sup>	9
Salt (NaCl), technical grade	3
Paper, filter pulp <sup>C</sup>	3

<sup>A</sup> Fisher Scientific Co. Catalog No. S153-3 (SPD S-S3) is satisfactory for this purpose.

<sup>B</sup> R. E. Carroll, Inc., Trenton, NJ (1-800-257-9365) Suwanee Clay (325 mesh) is satisfactory for this purpose.

<sup>C</sup> International Paper Co., 2 Manhattenville Rd. (901-419-7307) Paper filter pulp is satisfactory for this purpose.

8.2 Mix the dust components in a ball mill with approximately 25 mm (1 in.) diameter flint pebbles to the consistency of a fine talcum. Milling for 72 h is usually sufficient.

8.3 Dispense the dust from an 265 cm<sup>3</sup> (8 oz) wide-mouth bottle covered with 40-mesh screen. A few pebbles or marbles approximately 13 mm (0.5 in.) in diameter will help prevent screen clogging and keep the dust mixed.

8.4 Keep the dust dry prior to dispensing as well as in storage. The dust does not deteriorate upon aging if kept dry.

## 9. Sampling

9.1 Refer to applicable material specification for sampling instructions.

## 10. Test Specimens

10.1 Prepare a test specimen between 125 mm by 125 mm (5 in. by 5 in.) and 150 mm by 150 mm (6 in. by 6 in.) and of the thickness specified.