



Designation: ~~D5766/D5766M – 11 (Reapproved 2018)~~ D5766/D5766M – 23

Standard Test Method for Open-Hole Tensile Strength of Polymer Matrix Composite Laminates¹

This standard is issued under the fixed designation D5766/D5766M; the number immediately following the designation indicates the year of original adoption or, in the case of revision, the year of last revision. A number in parentheses indicates the year of last reapproval. A superscript epsilon (ϵ) indicates an editorial change since the last revision or reapproval.

1. Scope

1.1 This test method determines the open-hole tensile strength of multidirectional polymer matrix composite laminates reinforced by high-modulus fibers. The composite material forms are limited to continuous-fiber or discontinuous-fiber (tape or fabric, or both) reinforced composites in which the laminate is balanced and symmetric with respect to the test direction. The range of acceptable test laminates and thicknesses are described in 8.2.1.

1.2 The values stated in either SI units or inch-pound units are to be regarded separately as standard. The values stated in each system may not be exact equivalents; therefore, each system shall be used independently of the other. Combining values from the two systems may result in non-conformance with the standard.

1.2.1 Within the text the inch-pound units are shown in brackets.

1.3 *This standard does not purport to address all of the safety concerns, if any, associated with its use. It is the responsibility of the user of this standard to establish appropriate safety, health, and environmental practices and determine the applicability of regulatory limitations prior to use.*

1.4 *This international standard was developed in accordance with internationally recognized principles on standardization established in the Decision on Principles for the Development of International Standards, Guides and Recommendations issued by the World Trade Organization Technical Barriers to Trade (TBT) Committee.*

2. Referenced Documents

2.1 ASTM Standards:²

[D792 Test Methods for Density and Specific Gravity \(Relative Density\) of Plastics by Displacement](#)

[D883 Terminology Relating to Plastics](#)

[D2584 Test Method for Ignition Loss of Cured Reinforced Resins](#)

[D2734 Test Methods for Void Content of Reinforced Plastics](#)

[D3039/D3039M Test Method for Tensile Properties of Polymer Matrix Composite Materials](#)

[D3171 Test Methods for Constituent Content of Composite Materials](#)

[D3878 Terminology for Composite Materials](#)

[D5229/D5229M Test Method for Moisture Absorption Properties and Equilibrium Conditioning of Polymer Matrix Composite Materials](#)

[D8509 Guide for Test Method Selection and Test Specimen Design for Bolted Joint Related Properties](#)

¹ This test method is under the jurisdiction of ASTM Committee D30 on Composite Materials and is the direct responsibility of Subcommittee D30.05 on Structural Test Methods.

Current edition approved June 1, 2018; Sept. 1, 2023. Published July 2018; September 2023. Originally approved in 1995. Last previous edition approved in 2018 as D5766/D5766M – 11; D5766/D5766M – 11 (2018). DOI: 10.1520/D5766_D5766M-11R18; 10.1520/D5766_D5766M-23.

² For referenced ASTM standards, visit the ASTM website, www.astm.org, or contact ASTM Customer Service at service@astm.org. For *Annual Book of ASTM Standards* volume information, refer to the standard's Document Summary page on the ASTM website.



- E6 Terminology Relating to Methods of Mechanical Testing
E177 Practice for Use of the Terms Precision and Bias in ASTM Test Methods
E456 Terminology Relating to Quality and Statistics
E691 Practice for Conducting an Interlaboratory Study to Determine the Precision of a Test Method
E1309 Guide for Identification of Fiber-Reinforced Polymer-Matrix Composite Materials in Databases (Withdrawn 2015)³
E1434 Guide for Recording Mechanical Test Data of Fiber-Reinforced Composite Materials in Databases (Withdrawn 2015)³

3. Terminology

3.1 *Definitions*—Terminology D3878 defines terms relating to high-modulus fibers and their composites. Terminology D883 defines terms relating to plastics. Terminology E6 defines terms relating to mechanical testing. Terminology E456 and Practice E177 define terms relating to statistics. In the event of a conflict between terms, Terminology D3878 shall have precedence over the other standards.

3.2 *Definitions of Terms Specific to This Standard:—Standard—*

NOTE 1—If the term represents a physical quantity, its analytical dimensions are stated immediately following the term (or letter symbol) in fundamental dimension form, using the following ASTM standard symbology for fundamental dimensions, shown within square brackets: $[M]$ for mass, $[L]$ for length, $[T]$ for time, $[θ]$ for thermodynamic temperature, and $[nd]$ for non-dimensional quantities. Use of these symbols is restricted to analytical dimensions when used with square brackets, as the symbols may have other definitions when used without the brackets. Refer to Guide D8509.

3.2.1 *diameter-to-thickness ratio, D/t $[nd]$, n —in an open-hole specimen, the ratio of the hole diameter to the specimen thickness.*

3.2.1.1 *Discussion*—The diameter-to-thickness ratio may be either a nominal value determined from nominal dimensions or an actual value determined from measured dimensions.

3.2.2 *nominal value, n —a value, existing in name only, assigned to a measurable property for the purpose of convenient designation. Tolerances may be applied to a nominal value to define an acceptable range for the property.*

3.2.3 *principal material coordinate system, n —a coordinate system with axes that are normal to the planes of symmetry inherent to a material.*

3.2.3.1 *Discussion*—Common usage, at least for Cartesian axes (123, xyz , and so forth), generally assigns the coordinate system axes to the normal directions of planes of symmetry in order that the highest property value in a normal direction (for elastic properties, the axis of greatest stiffness) would be 1 or x , and the lowest (if applicable) would be 3 or z . Anisotropic materials do not have a principal material coordinate system due to the total lack of symmetry, while, for isotropic materials, any coordinate system is a principal material coordinate system. In laminated composites, the principal material coordinate system has meaning only with respect to an individual orthotropic lamina. The related term for laminated composites is “reference coordinate system.”

3.2.4 *reference coordinate system, n —a coordinate system for laminated composites used to define ply orientations. One of the reference coordinate system axes (normally the Cartesian x -axis) is designated the reference axis, assigned a position, and the ply principal axis of each ply in the laminate is referenced relative to the reference axis to define the ply orientation for that ply.*

3.2.5 *specially orthotropic, adj —a description of an orthotropic material as viewed in its principal material coordinate system. In laminated composites, a specially orthotropic laminate is a balanced and symmetric laminate of the $\{0_r/90_r\}_{ns}$ family as viewed from the reference coordinate system, such that the membrane-bending coupling terms of the laminate constitutive relation are zero.*

3.2.6 *width-to-diameter ratio, w/D $[nd]$, n —in an open-hole specimen, the ratio of the specimen width to the hole diameter.*

3.2.6.1 *Discussion*—The width-to-diameter ratio may be either a nominal value determined from nominal dimensions or an actual value determined from measured dimensions.

3.3 *Symbols:*

A = cross-sectional area of a specimen

CV = coefficient of variation statistic of a sample population for a given property (in percent)

D = hole diameter

³ The last approved version of this historical standard is referenced on www.astm.org.



h = specimen thickness

n = number of specimens per sample population

N = number of plies in laminate under test

F_x^{OHTu} = ultimate open-hole (notched) tensile strength in the test direction

P^{max} = maximum force carried by test specimen prior to failure

s_{n-1} = standard deviation statistic of a sample population for a given property

S_r = repeatability (within laboratory precision) standard deviation, calculated in accordance with Practice E691

S_R = reproducibility (between laboratory precision) standard deviation, calculated in accordance with Practice E691

w = specimen width

x_i = test result for an individual specimen from the sample population for a given property

\bar{x} = mean or average (estimate of mean) of a sample population for a given property

σ = normal stress

4. Summary of Test Method

4.1 A uniaxial tension test of a balanced, symmetric laminate is performed in accordance with Test Method D3039/D3039M, although with a centrally located hole. Edge-mounted extensometer displacement transducers are optional. Ultimate strength is calculated based on the gross cross-sectional area, disregarding the presence of the hole. While the hole causes a stress concentration and reduced net section, it is common aerospace practice to develop notched design allowable strengths based on gross section stress to account for various stress concentrations (fastener holes, free edges, flaws, damage, and so forth) not explicitly modeled in the stress analysis. Refer to Guide D8509 for additional test details.

4.2 The only acceptable failure mode for ultimate open-hole tensile strength is one which passes through the hole in the test specimen.

5. Significance and Use

5.1 This test method is designed to produce Refer to Guide D8509 notched tensile strength data for structural design allowables, material specifications, research and development, and quality assurance. Factors that influence the notched tensile strength and should therefore be reported include the following: material, methods of material fabrication, accuracy of lay-up, laminate stacking sequence and overall thickness, specimen geometry (including hole diameter, diameter-to-thickness ratio, and width-to-diameter ratio), specimen preparation (especially of the hole), specimen conditioning, environment of testing, specimen alignment and gripping, speed of testing, time at temperature, void content, and volume percent reinforcement. Properties that may be derived from this test method include the following:

5.1.1 Open-hole (notched) tensile strength (OHT).

6. Interferences

6.1 *Hole Preparation*—Due to the dominating presence of the notch, and the lack of need to measure the material response, results from this test method are relatively insensitive to parameters that would be of concern in an unnotched tensile property test. However, since the notch dominates the strength, consistent preparation of the hole, without damage to the laminate, is important to meaningful results. Damage due to hole preparation will affect strength results. Some types of damage, such as delaminations, can blunt the stress concentration due to the hole, increasing the force-carrying capacity of the specimen and the calculated strength. Other types of damage can reduce the calculated strength.

6.2 *Specimen Geometry*—Results are affected by the ratio of specimen width to hole diameter (w/D); this ratio should be maintained at 6, unless the experiment is investigating the influence of this ratio. Results may also be affected by the ratio of hole diameter to thickness (D/h); the preferred ratio is the range from 1.5 to 3.0 unless the experiment is investigating the influence of this ratio. Results may also be affected by specimen length⁴; the preferred specimen length is in the range from 200 to 300 mm [8.0 to 12.0 in.]. Shorter specimens (150 to 200 mm [6.0 to 8.0 in.]) may be utilized in accordance with the limitations defined in 8.2.2. The equivalence of test results from Configurations A and B is contingent upon several factors, including fiber strain-to-failure, resin strength and fracture toughness. Laminates with a propensity to develop sub-critical resin splits and cracks could potentially be affected by a change in specimen length due to closer grip proximity to the hole (and any longitudinal cracks that may develop).

6.1 *Material Orthotropy*—The degree of laminateRefer to Guide [D8509](#) orthotropy strongly affects the failure mode and measured OHT strength. Valid OHT strength results should only be reported when appropriate failure modes are observed, in accordance with [11.5](#).

6.4 *Thickness Scaling*—Thick composite structures do not necessarily fail at the same strengths as thin structures with the same laminate orientation (that is, strength does not always remain constant independent of specimen thickness). Thus, data gathered using this test method may not translate directly into equivalent thick-structure properties.

6.5 *Other*—Additional sources of potential data scatter in testing of composite materials are described in Test Method [D3039/D3039M](#).

7. Apparatus

7.1 Apparatus shall be in accordance with Test Method [D3039/D3039M](#). Additionally, a micrometer or gaggage capable of determining the hole diameter to ± 0.025 mm [± 0.001 in.] is required.

8. Sampling and Test Specimens

8.1 *Sampling*—Sampling shall be in accordance with Test Method [D3039/D3039M](#).

8.2 *Geometry*—The specimen geometry shall be in accordance with Test Method [D3039/D3039M](#), as modified by the following, and illustrated by the schematic of [Fig. 1](#). Any variation of the stacking sequence, specimen width or length, or hole diameter from that specified shall be clearly noted in the report.

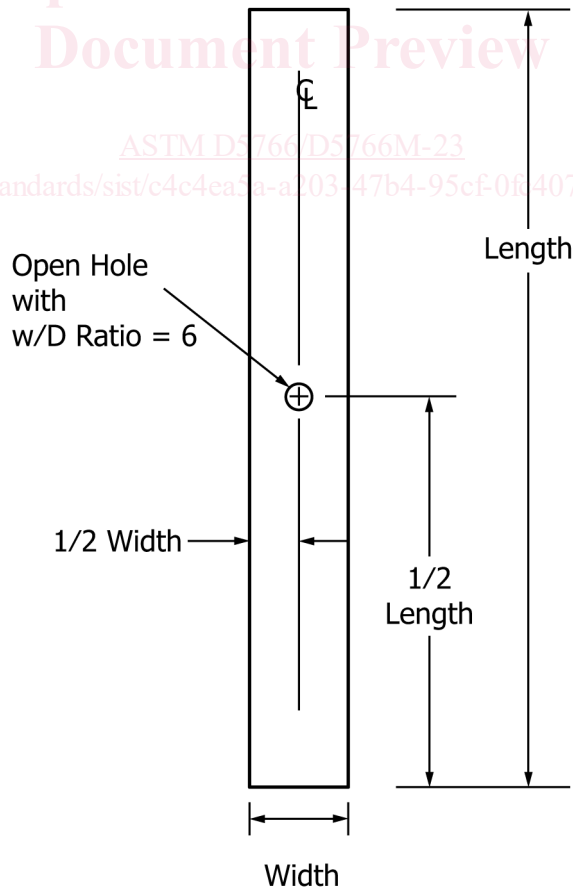

FIG. 1 Schematic of Open-Hole Tension Test Specimen

8.2.1 *Stacking Sequence*—The standard laminate shall have multidirectional fiber orientations (fibers shall be oriented in a minimum of two directions), and balanced and symmetric stacking sequences. Nominal thickness shall be ~~2.5 mm [0.10 in.]~~, 2.5 mm [0.10 in.], with a permissible range of ~~2 to 4 mm [0.080 to 0.160 in.]~~, 2 mm to 4 mm [0.080 in. to 0.160 in.], inclusive. Fabric laminates containing satin-type weaves shall have symmetric warp surfaces, unless otherwise noted in the report.

NOTE 1—Typically a $[45_i/-45_i/0_j/90_k]_{ms}$ tape or $[45_i/0_j]_{ms}$ fabric laminate should be selected such that a minimum of 5 % of the fibers lay in each of the four principal orientations. This laminate design has been found to yield the highest likelihood of acceptable failure modes.

8.2.2 *Configuration:*

8.2.2.1 *Configuration A*—The width of the specimen is ~~$36 \pm 1 \text{ mm [1.50} \pm 0.05 \text{ in.]}$~~ $36 \text{ mm} \pm 1 \text{ mm [1.50 in.} \pm 0.05 \text{ in.]}$ and the length range is ~~200 to 300 mm [8.0 to 12.0 in.]~~, 200 mm to 300 mm [8.0 in. to 12.0 in.]. The notch consists of a centrally located hole, ~~$6 \pm 0.06 \text{ mm [0.250} \pm 0.003 \text{ in.]}$~~ $6 \text{ mm} \pm 0.06 \text{ mm [0.250 in.} \pm 0.003 \text{ in.]}$ in diameter, centered by length to within ~~$0.12 \text{ mm [0.005 in.]}$~~ $0.12 \text{ mm [0.005 in.]}$ and by width to within ~~$0.05 \text{ mm [0.002 in.]}$~~ $0.05 \text{ mm [0.002 in.]}$. While tabs may be used, they are not required and generally not needed, since the open hole acts as sufficient stress riser to force failure in the notched region. Configuration A is preferred for the general laminate stacking sequences defined in 8.2.1. ~~8.2.1~~ because it is long enough to ensure a uniform strain field is achieved in the specimen outside of the influence of the hole.

8.2.2.2 *Configuration B*—The width of the specimen is ~~$36 \pm 1 \text{ mm [1.50} \pm 0.05 \text{ in.]}$~~ $36 \text{ mm} \pm 1 \text{ mm [1.50 in.} \pm 0.05 \text{ in.]}$ and the length range is ~~150 to 200 mm [6.0 to 8.0 in.]~~, 150 mm to 200 mm [6.0 in. to 8.0 in.]. The notch consists of a centrally located hole, ~~$6 \pm 0.06 \text{ mm [0.250} \pm 0.003 \text{ in.]}$~~ $6 \text{ mm} \pm 0.06 \text{ mm [0.250 in.} \pm 0.003 \text{ in.]}$ in diameter, centered by length to within ~~$0.12 \text{ mm [0.005 in.]}$~~ $0.12 \text{ mm [0.005 in.]}$ and by width to within ~~$0.05 \text{ mm [0.002 in.]}$~~ $0.05 \text{ mm [0.002 in.]}$. While tabs may be used, they are not required and generally not needed, since the open hole acts as sufficient stress riser to force failure in the notched region. Configuration B is limited to quasi-isotropic laminate stacking sequences, typically a $[45_m/-45_m/0_m/90_m]_{ns}$ tape or $[45_m/0_m]_{ns}$ fabric laminate, with a specimen grip length of ~~35 to 55 mm [1.4 to 2.0 in.]~~ $35 \text{ mm to } 55 \text{ mm [1.4 in. to } 2.0 \text{ in.]}$

NOTE 2—The ungripped specimen length for Configuration B shall not be less than ~~75 mm [3.0 in.]~~ 75 mm [3.0 in.] as shorter ungripped lengths may result in an unacceptable influence upon failure at or near to the hole.

8.3 *Specimen Preparation*—Special care shall be taken to ensure that creation of the specimen hole does not delaminate or otherwise damage the material surrounding the hole. Holes should be drilled undersized and reamed to final dimensions. Record and report the specimen hole preparation methods. Other specimen preparation techniques and requirements are noted in Test Method **D3039/D3039M**.

9. Calibration

9.1 Calibration shall be in accordance with Test Method **D3039/D3039M**.

10. Conditioning

10.1 The recommended pre-test condition is effective moisture equilibrium at a specific relative humidity as established by Test Method **D5229/D5229M**; however, if the test requestor does not explicitly specify a pre-test conditioning environment, no conditioning is required and the test specimens may be tested as prepared.

10.2 The pre-test specimen conditioning process, to include specified environmental exposure levels and resulting moisture content, shall be reported with the test data.

NOTE 3—The term moisture, as used in Test Method **D5229/D5229M**, includes not only the vapor of a liquid and its condensate, but the liquid itself in large quantities, as for immersion.

10.3 If no explicit conditioning process is performed the specimen conditioning process shall be reported as “unconditioned” and the moisture content as “unknown.”

11. Procedure

11.1 *Parameters To Be Specified Prior to Test:*



11.1.1 The tension specimen sampling method, specimen type and geometry, and conditioning travelers (if required).

11.1.2 The tensile properties and data reporting format desired.

NOTE 4—Determine specific material property, accuracy, and data reporting requirements prior to test for proper selection of instrumentation and data recording equipment. Estimate the specimen strength to aid in transducer selection, calibration of equipment, and determination of equipment settings.

11.1.3 The environmental conditioning test parameters.

11.1.4 If performed, extensometry requirements and related calculations.

11.1.5 If performed, the sampling method, specimen geometry, and test parameters used to determine density and reinforcement volume.

11.2 General Instructions:

11.2.1 Report any deviations from this test method, whether intentional or inadvertent.

11.2.2 If specific gravity, density, reinforcement volume or void volume are to be reported then obtain these samples from the same panels being tension tested. Specific gravity and density may be evaluated by means of Test Methods **D792**. Volume percent of the constituents may be evaluated by one of the matrix digestion procedures of Test Method **D3171**, or, for certain reinforcement materials such as glass and ceramics, by the matrix burn-off technique of Test Method **D2584**. The void content equations of Test Methods **D2734** are applicable to both Test Method **D2584** and the matrix digestion procedures.

11.2.3 Condition the specimens as required. Store the specimens in the conditioned environment until test time, if the test environment is different than the conditioning environment.

11.2.4 Following any conditioning, but before the tensile testing, measure and report the specimen hole diameter, D , to the nearest 0.025 mm [0.001 in.]. ~~0.025 mm [0.001 in.]~~. Inspect the hole and areas adjacent to the hole for delaminations. Report the location and size of any delaminations found. Perform other measurements in accordance with Test Method **D3039/D3039M**.

11.3 *Tensile Testing*—Perform other measurements, and the tension test of the laminate specimen, in accordance with the Procedure section of Test Method **D3039/D3039M**. If strain response local to the hole is to be determined, attach either one or two extensometers to the specimen edge(s) ensuring the hole is located within the extensometer gage section.

NOTE 5—When testing a conditional specimen at elevated temperature with no fluid exposure control, the percentage moisture loss of the specimen prior to test completion may be estimated by placing a conditioned traveler coupon of known weight within the test chamber at the same time the specimen is placed in the chamber. Upon completion of the test, the traveler coupon is removed from the chamber, weighed, and the percentage weight calculated and reported.

11.4 *Data Recording*—Record force versus crosshead displacement (and force versus strain, if extensometers are utilized) continuously, or at frequent regular intervals; for this test method, a sampling rate of 2 to 3 data recordings per second, and a target minimum of 100 data points per test are recommended. If any initial failures are noted, record the force, displacement, and mode of damage at such points. Record the method used to determine the initial failure (visual, acoustic emission, etc.). Record the maximum force, the failure force (if different from the maximum force), and the crosshead displacement at, or as near as possible to, the moment of rupture (if specifically requested).

NOTE 6—Other valuable data that can be useful in understanding testing anomalies and gripping or specimen slipping problems include force versus time data.

11.5 *Failure Modes*—Failures that do not occur at the hole are not acceptable failure modes and the data shall be noted as invalid. The failure is often heavily influenced by delamination and the failure mode may exhibit much delamination. Three-place failure mode descriptors for these modes, following those given in Test Method **D3039/D3039M** and summarized in **Table 1**, shall be used. This notation uses the first place to describe failure type, the second to describe failure area, and the last to describe failure location. Failure mode codes for valid tests for this test method are limited to *GM, where the second and third place holders are limited to “Gage” “Gauge Middle.” The first place holder would normally be either L for Lateral, A for Angled, or M for Multi-mode. **Fig. 2** illustrates these three acceptable failure modes. The mode of failure may be found to vary on different sides of the hole.



TABLE 1 Three-Place Failure Mode Codes

First Character		Second Character		Third Character	
Failure Type	Code	Failure Area	Code	Failure Location	Code
Angled edge	A	Inside grip/tab	I	Bottom	B
Delamination	D	At grip/tab	A	Top	T
Grip/tab	G	<1W from grip/tab	W	Left	L
Lateral	L	Gage	G	Right	R
Lateral	L	Gauge	G	Right	R
Multi-mode	M(xyz)	Multiple areas	M	Middle	M
long. Splitting	S	Various	V	Various	V
Explosive	X	Unknown	U	Unknown	U
Other	O				

12. Validation

12.1 Values for ultimate properties shall not be calculated for any specimen that breaks at some obvious flaw, unless such flaw constitutes a variable being studied. Retests shall be performed for any specimen on which values are not calculated.

12.2 A significant fraction of failures in a sample population occurring away from the center hole shall be cause to re-examine the means of force introduction into the material. Factors considered should include the grip pressure, grip alignment, and specimen thickness taper.

13. Calculation

13.1 *Ultimate Strength*—Calculate the ultimate open-hole tensile strength using Eq 1 and report the results to three significant figures.

$$F_x^{OHTu} = P^{max}/A \quad (1)$$

where:

F_x^{OHTu} = ultimate open-hole (notched) tensile strength in the test direction, MPa [psi],

P^{max} = maximum force carried by test specimen prior to failure, N [lbf], and

A = gross cross-sectional area (disregarding hole) from Test Method D3039/D3039M, mm² [in.²].

NOTE 7—The hole diameter is ignored in the strength calculation; the gross cross-sectional area is used.

13.2 *Width to Diameter Ratio*—Calculate the actual width to diameter ratio, as shown in Eq 2, and report the result to three significant figures. Report both the nominal ratio calculated using nominal values and the actual ratio calculated with measured dimensions.

$$w/D \text{ ratio} = \frac{w}{D} \quad (2)$$

where:

w = width of specimen across hole, mm [in.], and

D = diameter of hole, mm [in.].

13.3 *Diameter to Thickness Ratio*—Calculate the actual diameter to thickness ratio, as shown in Eq 3, and report the result to three significant figures. Report both the nominal ratio calculated using nominal values and the actual ratio calculated with measured dimensions.

$$D/h \text{ ratio} = \frac{D}{h} \quad (3)$$

where:

D = diameter of hole, mm [in.], and