



Designation: C1860 – 23c<sup>ε1</sup>

# Standard Test Methods for Measurement of Tensile Strength or Bond Strength of Portland Cement-Based Plaster by Direct Tension<sup>1</sup>

This standard is issued under the fixed designation C1860; the number immediately following the designation indicates the year of original adoption or, in the case of revision, the year of last revision. A number in parentheses indicates the year of last reapproval. A superscript epsilon ( $\epsilon$ ) indicates an editorial change since the last revision or reapproval.

<sup>ε1</sup> NOTE—Editorially corrected [Appendix X4](#) in September 2023.

## 1. Scope

1.1 These test methods cover procedures for determining the tensile strength of a section of portland cement-based plaster, the bond strength between portland cement-based plaster and a solid plaster base, or the fastener pull-out or lath pull-over strength for portland cement-based plaster bases over framing in either an exterior (stucco) or interior application. The test procedures are destructive in nature within the localized test areas and, after testing is concluded, require appropriate repair of the finish system as well as any underlying materials damaged during testing.

1.2 These test methods are suitable for use on portland cement-based plaster finish systems on both new and existing construction. Test methods shall be conducted a minimum of 28 days after application of the portland cement-based plaster. Mechanical Load Test Method A and Vacuum Chamber Testing shall be used to determine the tensile strength or bond strength of direct-applied portland cement-based plaster and may be useful in evaluating the efficacy of different surface preparation characteristics, bonding agents, or both. Mechanical Load Test Method B and Vacuum Chamber Testing shall be used to determine the tensile strength of portland cement-based plaster installed over mechanically attached lath.

1.3 These test methods are suitable for use in both laboratory and field samples. No correlation shall be made between laboratory and field testing.

1.4 These test methods are not intended to evaluate the performance of the underlying construction or framing members. Test results on a particular building may be variable depending on the specimen location, condition, and installation, and are subject to interpretation by the test specifier.

1.5 These test methods are not intended to evaluate the performance of coatings applied to the surface of the portland cement-based plaster.

1.6 These test methods are not intended to be a pre-construction qualifier to determine if the surfaces are appropriate for application of portland cement plaster. The test methods are intended to be used as a tool to quantitatively evaluate existing portland cement plaster cladding that is suspected of questionable bond or uncertain fastening to the substrate.

1.7 The values stated in inch-pound units are to be regarded as standard. The values given in parentheses are mathematical conversions to SI units that are provided for information only and are not considered standard.

1.8 *This standard may involve hazardous materials, operations, or equipment. This standard does not purport to address all of the safety concerns, if any, associated with its use. It is the responsibility of the user of this standard to establish appropriate safety, health, and environmental practices and determine the applicability of regulatory limitations prior to use.*

1.9 *This international standard was developed in accordance with internationally recognized principles on standardization established in the Decision on Principles for the Development of International Standards, Guides and Recommendations issued by the World Trade Organization Technical Barriers to Trade (TBT) Committee.*

## 2. Referenced Documents

2.1 *ASTM Standards:*<sup>2</sup>

[C11 Terminology Relating to Gypsum and Related Building Materials and Systems](#)

[C219 Terminology Relating to Hydraulic and Other Inorganic Cements](#)

[E2359/E2359M Test Method for Field Pull Testing of an](#)

<sup>1</sup> These test methods are under the jurisdiction of ASTM Committee C11 on Gypsum and Related Building Materials and Systems and is the direct responsibility of Subcommittee C11.02 on Specifications and Test Methods for Accessories and Related Products.

Current edition approved June 1, 2023. Published June 2023. Originally approved in 2018. Last previous edition approved in 2023 as C1860 – 23b. DOI: 10.1520/C1860-23CE01.

<sup>2</sup> For referenced ASTM standards, visit the ASTM website, [www.astm.org](http://www.astm.org), or contact ASTM Customer Service at [service@astm.org](mailto:service@astm.org). For *Annual Book of ASTM Standards* volume information, refer to the standard's Document Summary page on the ASTM website.

## In-Place Exterior Insulation and Finish System Clad Wall Assembly

2.2 *American Society of Civil Engineers Standard:*<sup>3</sup>

**SEI/ASC 7 Minimum Design Loads for Buildings and Other Structures**

2.3 *U.S. Department of Commerce Standard:*<sup>4</sup>

**Voluntary Product Standard PS 1 Structural Plywood**

### 3. Terminology

3.1 Terms shall be as defined in Terminology **C11** and Terminology **C219**, except as modified herein.

#### 3.2 Definitions:

3.2.1 *adhesive, n*—high strength adhesive of appropriate type to adhere test module to plaster; expanding foam adhesives shall be prohibited.

3.2.2 *bond strength, n*—the maximum stress as measured in force per unit area that a plaster specimen can withstand in direct tension before failure either (a) between any two stucco coats, or (b) between the base coat(s) and the substrate.

3.2.3 *fastener pull-out, n*—failure mode by which the fastener released from the substrate in withdrawal.

3.2.4 *lath, n*—a mechanically attached base material used to support plaster including metal plaster bases (expanded metal lath, woven wire plaster base, and welded wire lath) and non-metallic plaster bases.

3.2.5 *lath pull-over, n*—failure mode by which the lath (metal or non-metallic) pulls over the head of the fastener, leaving the fastener intact.

3.2.6 *proof, n*—the maximum safe test load as set in this standard.

3.2.7 *substrate, n*—the surface to which the plaster is attached, either directly or with lath (metal or non-metallic).

3.2.8 *tensile load, n*—the load as measured in force that a plaster specimen can withstand in direct tension at failure.

3.2.9 *tensile strength, n*—the stress as measured in force per unit area that a plaster specimen can withstand in direct tension before failure within any individual stucco coat.

### 4. Significance and Use

4.1 The purpose of the test methods in this standard is to measure the tensile strength or bond strength of portland cement-based plaster to its substrate. The values obtained using the test methods are not purported to be representative of the actual wind load capacity or other structural properties of a specific portland cement-based plaster installation but may be helpful in assessing such load capacities.

4.2 Because the test methods described in this standard are used for evaluation of portland cement-based plaster cured at least 28 days, load results obtained by either test method must be interpreted based on sound engineering practice, applicable building regulations, and codes having jurisdiction. The deci-

sion of whether to use the load results directly or to use the load results as modified by an appropriate safety factor to obtain acceptable working loads is left to the discretion of the test specifier. Determination of an appropriate safety factor shall be left to the discretion of the test specifier. Methods to calculate a safety factor and a maximum permitted working load are provided in the appendices.

4.3 When the test methods contained in this standard are used on test specimens installed on existing structures, the test results shall not be generalized to a larger wall area without sufficient test sampling. Such efforts should be based on engineering experience and judgment of the test specifier.

### 5. Apparatus

#### 5.1 Mechanical Testing Apparatus:

5.1.1 Pull test frame fabricated from metal or wood, as required, with capability of applying a concentric pull force to the test module and distributing reaction forces on adjacent wall components. It is intended that the pull test frame be easily transportable and relocated so that it can readily be used on saw-horses, scaffolding, lifts, and swing-stages. The pull test frame as specified in Test Method **E2359/E2359M** shall be permitted in this test method.

5.1.2 A coupling device to connect the pull test module to the load cell and test frame. The coupling device shall be designed to withstand the tensile capacity of the device without yielding, and to transmit the tensile force parallel to and in line with centerline of the test specimen without imparting torsion or bending stress to the specimen. The coupling device shall be fitted with a metal rod fixed at the load cell and threaded at the opposite end to permit the application of tensile loads to the test module in a controlled manner with incrementally increasing load intensities.

5.1.3 A load cell with force gauge having a capacity of at least the proof values specified in **7.1.3**, and an accuracy of  $\pm 2\%$ . Load cells shall be calibrated annually.

5.1.4 Electric angle grinder with masonry cutting blade of sufficient type and diameter to fully penetrate plaster thickness and lath and grinding blade to level surface of plaster.

5.1.5 Miscellaneous hand tools, bolts, and connection hardware.

#### 5.1.6 Test Method A (Direct-applied Stucco Testing):

5.1.6.1 Pull test module consisting of a minimum 6 by 6 in. (150 by 150 mm) and maximum 24 by 24 in. (610 by 610 mm) U.S. DOC Voluntary Product Standard PS 1 rated plywood minimum of  $\frac{3}{4}$  in. (19 mm) nominal thickness bonding panel (one for each specimen intended for testing) and one minimum  $\frac{1}{4}$  in. (6 mm) thick steel plate transfer panel sized to match length and width of the wooden bonding panel which is moved from specimen to specimen (see **Note 1**). The steel transfer panel shall include an integral steel nut located at the plan center of the plate of size to receive the threaded rod that connects the load cell to the transfer panel and provisions for  $\frac{7}{8}$  in. (22 mm) length, No. 14 wood screws to fasten the steel transfer panel to the plywood bonding panel. Adhere one nominal  $\frac{3}{4}$  in. (19 mm) thick wooden bonding panel to the surface of the stucco at each specimen location. For testing purposes, temporarily fasten the steel transfer panel at each

<sup>3</sup> Available from American Society of Civil Engineers (ASCE), 1801 Alexander Bell Dr., Reston, VA 20191, <http://www.asce.org>.

<sup>4</sup> Available from National Institute of Standards and Technology (NIST), 100 Bureau Dr., Stop 1070, Gaithersburg, MD 20899-1070, <http://www.nist.gov>.

adhered plywood bonding panel in succession. Fasteners between the steel transfer panel and plywood bonding panel shall be spaced at a minimum 2 in. (50 mm) on center and maximum 2 in. (50 mm) edge distance. (See **Figs. 1 and 2** for an example of a 12 by 12 in. (300 by 300 mm) test module.)

**NOTE 1**—Pull test module shall be sized as large as possible to capture as large of a stucco area as possible. In consideration of geometrical constraints and safety hazards associated with the weight and size of the steel transfer panels sized to match the plywood bonding panels, a minimum pull test module size of 6 by 6 in. (150 by 150 mm) shall be permitted.

### 5.1.7 Test Method B (For Testing Stucco over Mechanically Attached Lath):

5.1.7.1 Pull test module consisting of a 26 by 26 in. (660 by 660 mm) U.S. DOC Voluntary Product Standard PS 1 rated plywood minimum of  $\frac{3}{4}$  in. (19 mm) nominal thickness bonding panel (one for each specimen intended for testing) and one 26 by 26 by  $\frac{1}{4}$  in. (660 by 660 by 6 mm) thick steel plate transfer panel which is moved from specimen to specimen. The steel transfer panel shall include an integral steel nut located at the plan center of the plate of size to receive the threaded rod that connects the load cell to the transfer panel and provisions for  $\frac{7}{8}$  in. (22 mm) length, No. 14 wood screws to fasten the steel transfer panel to the plywood bonding panel. Adhere one  $\frac{3}{4}$  in. (19 mm) thick wooden bonding panel to the surface of the stucco at each specimen location. For testing purposes, temporarily fasten the steel transfer panel at each adhered plywood bonding panel in succession. Fasteners between the steel transfer panel and plywood bonding panel shall be spaced at a minimum 2 in. (50 mm) on center and maximum 2 in. (50 mm) edge distance. (See **Figs. 3 and 4** for an example of a 26 by 26 in. (660 by 660 mm) test module.)

5.1.8 As an alternate to the  $\frac{1}{4}$  in. (6 mm) steel transfer panel specified in 5.1.6.1 and 5.1.7.1, the test specifier shall be permitted to substitute a minimum  $\frac{3}{4}$  in. (19 mm) U.S. DOC Voluntary Product Standard PS 1 rated plywood transfer panel of equivalent dimensions.

5.1.9 An exploded view of the test assembly components (pull test frame, coupling device, load cell, and pull test module as described in 5.1.1, 5.1.2, 5.1.3, 5.1.6, and 5.1.7, respectively) is shown in **Fig. 5**. The feet of the pull test frame shall be of size and thickness to adequately distribute the loads to the wall without interfering with the performance of the test.

### 5.2 Vacuum Chamber Apparatus:

5.2.1 Chamber test frame shall be constructed of acrylic, polycarbonate, metal, or wood with a clear plastic window to permit viewing of the test specimen. The test frame shall be sufficiently strong to withstand the necessary anticipated negative pressure.

5.2.2 A pressure sensing device (for example, a manometer) for measuring the negative pressure shall be located inside the chamber or located outside the chamber such that a pressure tap is located within the chamber to measure internal negative pressure. The device shall be calibrated to indicate negative pressures in increments of no greater than  $3 \pm 0.5$  psf (145  $\pm$  20 Pa). The design or safety features of the device shall not be changed to increase negative pressures above the design or allowable values of the chamber.

5.2.3 An additional pressure tap and pressure sending device (for example, a manometer) shall be installed to measure the pressure at the interface of the stucco and the solid substrate (in other words, the back side of the stucco) to ensure a differential pressure during testing and measure interior pressurization values, if any. Apply sealant around the exterior circumference of the pressure tap and tubing to prevent incorrect readings. This pressure tap shall be permitted to be installed outside of the chamber to prevent damage during testing. Location of the pressure tap outside of the confines of the vacuum chamber shall be limited to within 3 in. (75 mm) of the chamber. The devices shall be calibrated to indicate negative pressures in increments of no greater than  $3 \pm 0.5$  psf (145  $\pm$  20 Pa).

5.2.4 Vacuum generating equipment shall have sufficient capacity to create the negative pressures required for the test. The chamber vacuum equipment shall be equipped with controls to maintain the constant negative pressure at each test pressure increment.

5.2.5 Measurement of stucco surface deflections within the test area shall be permitted. A deflection measurement device (such as a dial indicator), with graduations of at least 0.002 in. (0.05 mm) units and having at least a 2 in. (50 mm) range, mounted at the center of a 2 by 2 in. (50 by 50 mm) aluminum bar or member of equivalent stiffness with a length equivalent to the long dimension of the test chamber shall be provided for such measurement. The deflection measurement device shall be installed with a clear distance of at least 2 in. (50 mm) from the stucco surface to allow for measurement.

5.2.6 A cutting device (for example, an electric angle grinder) with a masonry cutting blade of sufficient type and diameter to fully penetrate plaster thickness and lath (where applicable).

5.2.7 Miscellaneous hand tools, bolts, and connection hardware.

## 6. Test Specimen

### 6.1 Sampling:

6.1.1 Sampling locations and number of specimens shall be determined by test specifier.

6.1.2 Test Method A (direct-applied stucco testing) sampling shall fall within three categories as specified in this section.

6.1.2.1 *Blind Sampling*—Sampling specified without any knowledge, perception, or expectation of the results shall be referred to as blind sampling. Locations and number of blind sampling specimens shall be determined by the test specifier.

6.1.2.2 *Targeted Sampling*—Where sampling is targeted in areas with suspect deficiencies, such sampling shall be identified and the means by which the targeted areas were identified (for example, acoustical sounding) shall be described in the report.

6.1.2.3 *Proof Sampling*—Where sampling is targeted in areas to validate or verify that the stucco is properly bonded (proof sampling), such sampling shall be identified and the means by which the targeted areas were identified (for example, acoustical sounding) shall be described in the report.

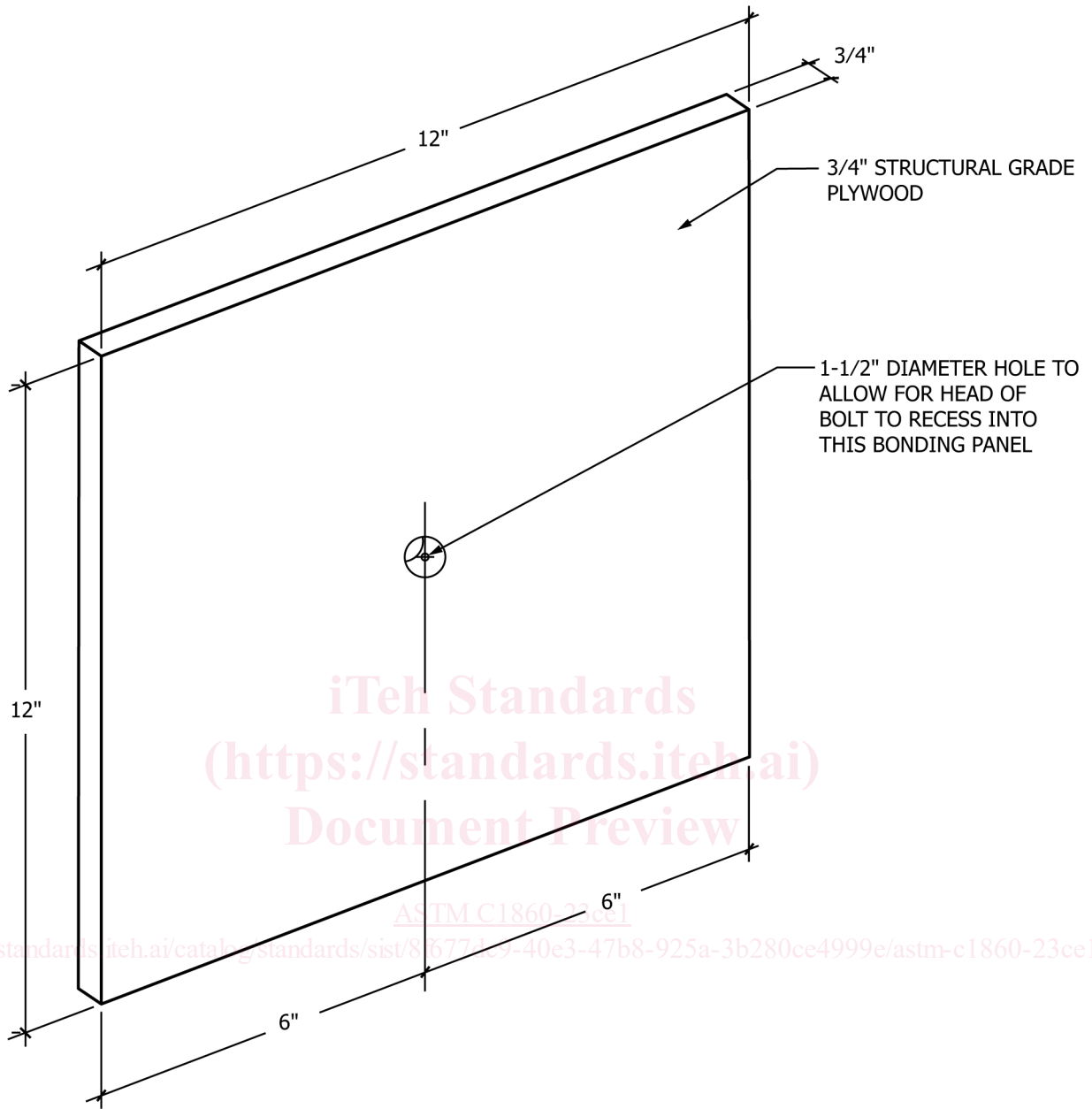

**BONDING PANEL**

FIG. 1 Example of 12 by 12 in. (300 by 300 mm) Bonding Panel

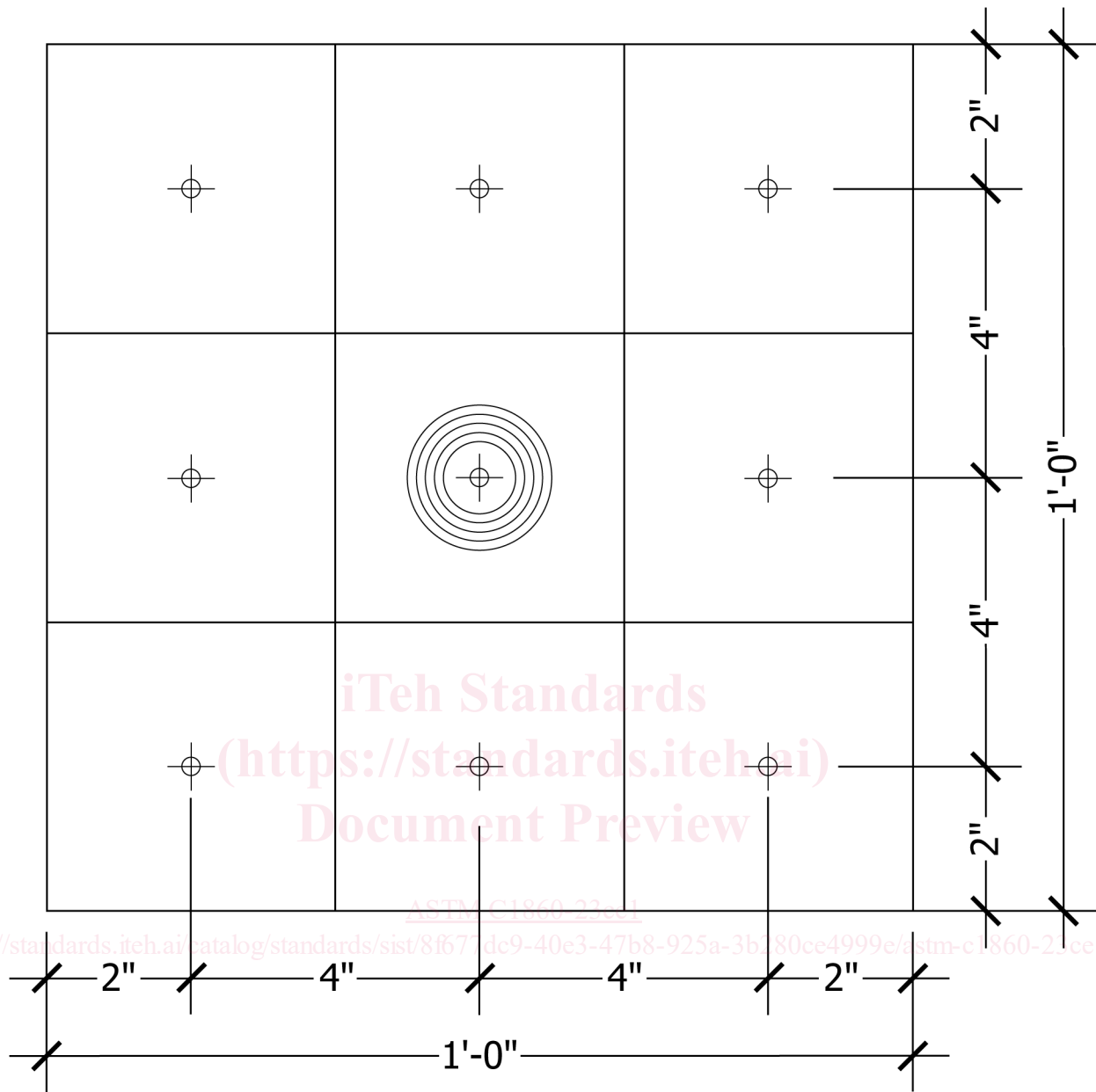

(8) #14 1/4" DIAM. × 7/8" WOOD LAG SCREWS

FIG. 2 Sample Layout of 12 in. (300 mm) Square Steel Bolting Template

6.1.3 Test Method B (stucco over mechanically attached lath testing) sampling shall be blind or targeted as defined in 6.1.2.1 and 6.1.2.2, respectively.

6.2 Surface Preparation:

6.2.1 Mechanical Tensile Load Apparatus (Methods A and B).

6.2.1.1 Remove all surface contaminants, loose debris, and dust that may interfere with bond.

6.2.1.2 If surface texture profile of plaster is such that good bond cannot be achieved, grind the surface texture to a level surface that permits good bond.

6.2.2 Vacuum Test Method—Surface preparation of surfaces is generally not required for the vacuum test method unless the

specified vacuum cannot be obtained. Where the specified vacuum cannot be obtained because of the surface texture in the surface of the stucco, preparation of the surface via hand grinding shall be permitted.

6.3 Mechanical Tensile Load Testing—Test Method A:

6.3.1 Where testing is to be performed at a targeted area of suspected unbonded or debonded stucco (determined through sounding or another applicable method), the area to be tested shall be a square equal to the suspected area of unbonded or debonded stucco multiplied by a factor of two, up to a maximum area of 24 by 24 in. (610 by 610 mm). Where testing is randomized, the area to be tested shall be sized to match the wood bonding panel as described in 5.1.6.1.

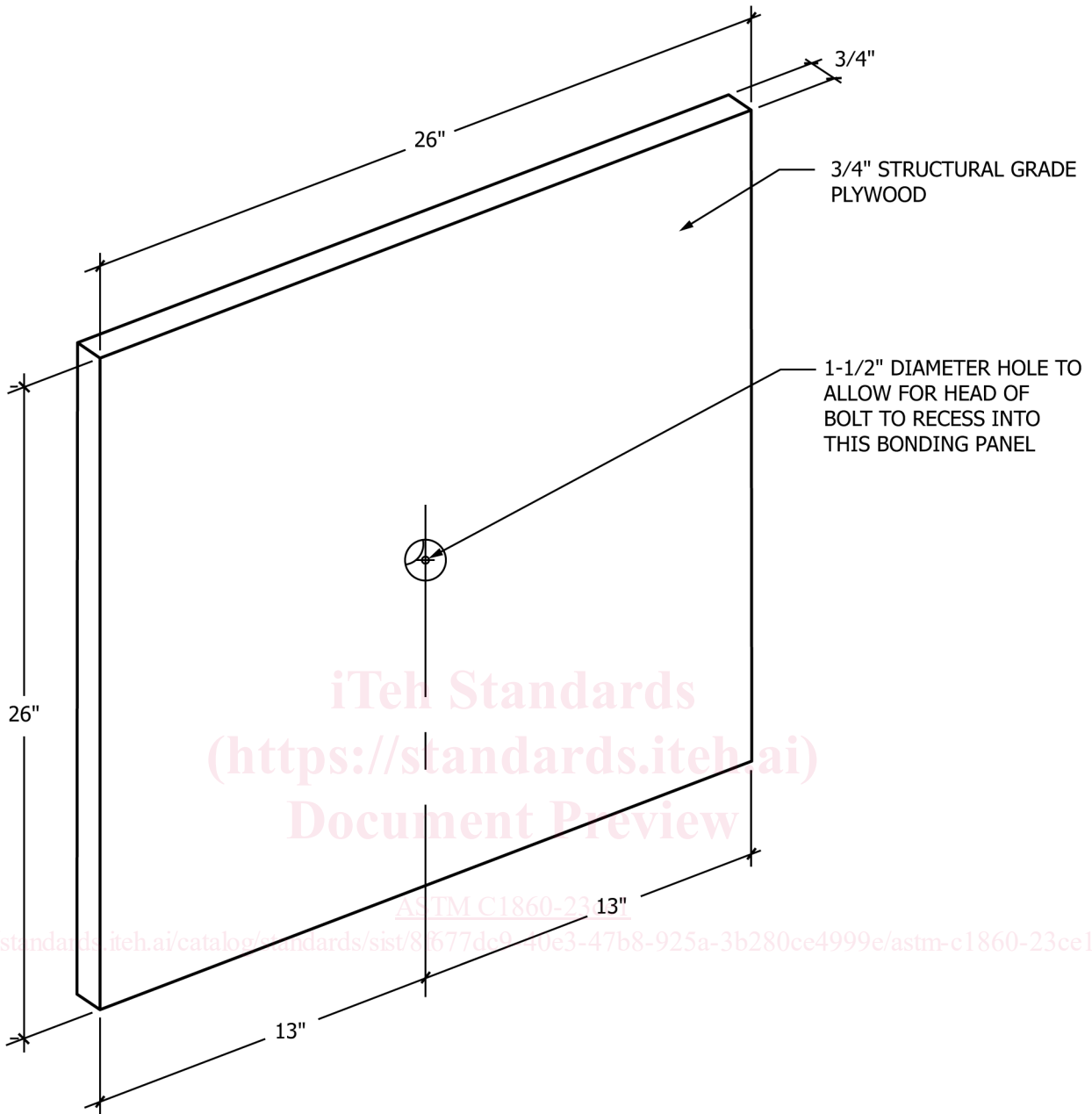

### BONDING PANEL

FIG. 3 Example of 26 in. (660 mm) Square Plywood Bonding Panel for Framing Members Spaced at 24 in. (610 mm) or Less

6.3.2 Where test samples are located adjacent to utility penetrations, geometric conditions (for example, changes in planarity, corners, edges, etc.), or other features that will not allow for safe mounting or operation of the testing apparatus, the test specifier shall be permitted to modify the size and location of the test. These modifications shall be reported, described, and justified in the report in accordance with Section 9 of this test method.

6.3.3 Mark an outline over the area to be tested as described in 6.3.1. Cut along the outline through the full depth of the stucco and lath, taking care to avoid damaging the substrate. Ensure that the cut depth and width is adequate to isolate the test area and prevent influence of the test results. After cutting

is complete, apply air impermeable tape over the scored joint to prevent air leakage during testing.

6.3.4 Attach the plywood bonding panel to the surface of the test specimen using the adhesive. Apply sufficient amount(s) of adhesive to allow for development of proof loading. Ensure that the plywood is centered on the test specimen and the edges of the plywood align with the edges of the score cut. Apply and cure the adhesive in accordance with the manufacturer's instructions. Prevent adhesive that drips down the side of the specimen and into the annular cut from setting by wiping clean; if setting occurs, cutting along the outline of the specimen shall be repeated. Temporarily brace the panel to the specimen as necessary to prevent slippage while adhesive cures. Provide

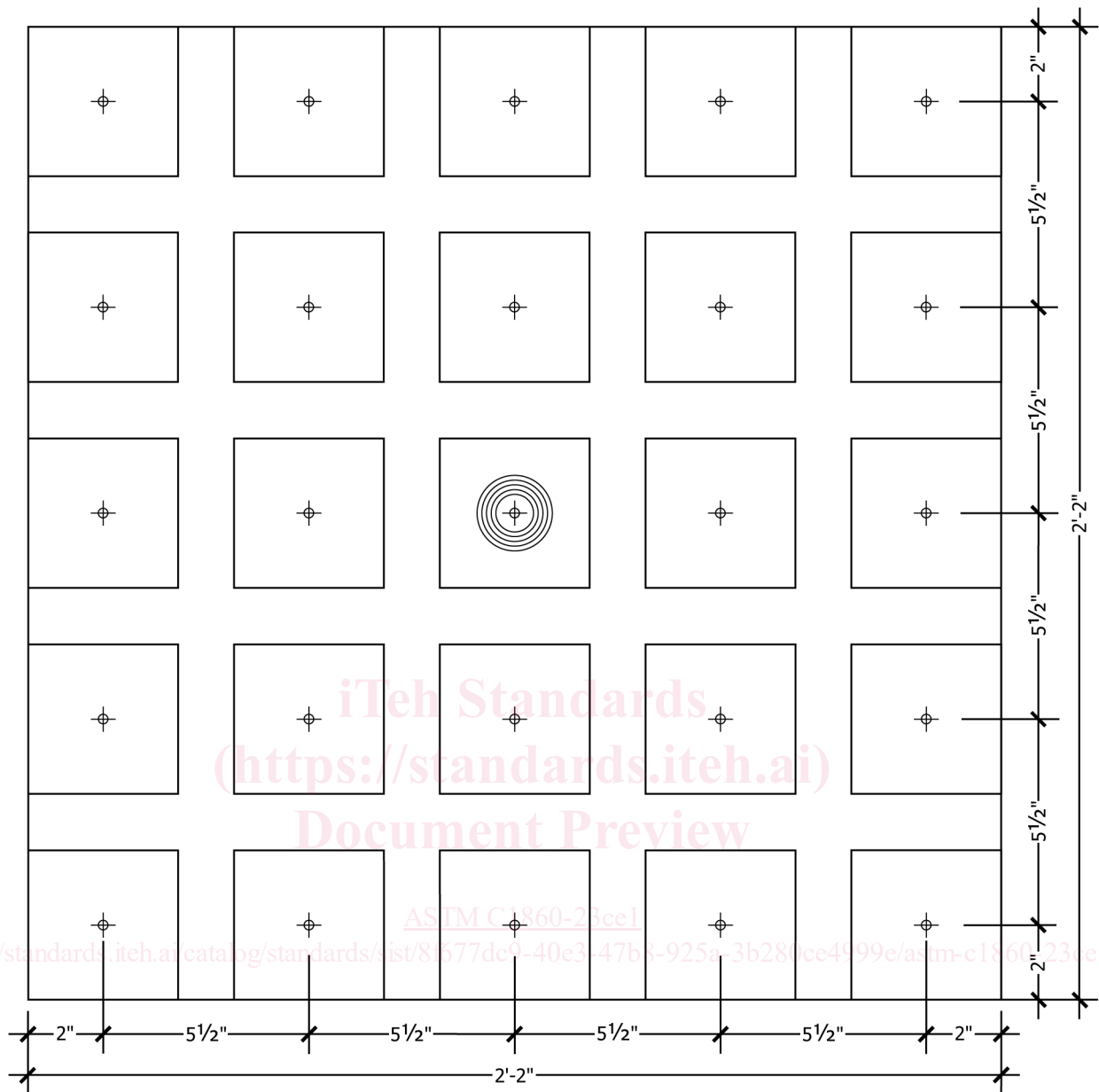

(24) #14 1/4" DIAM. × 7/8" WOOD LAG SCREWS

FIG. 4 Sample Layout of 26 in. (660 mm) Square Steel Bolting Template for Framing Members Spaced at 24 in. (610 mm) or Less

temporary protection as required by the adhesive manufacturer's installation instructions.

6.4 Mechanical Tensile Load Testing—Test Method B:

6.4.1 Determine the location of framing members within the sampling location via non-destructive testing methods, such as infrared thermography.

6.4.2 Mark a 26 in. (660 by 660 mm) outline centered over the framing members. Cut along the outline through the full depth of the stucco and plaster base, only scoring the sheathing and taking care to avoid damaging the framing members.

6.4.3 Attach the plywood bonding panel to the surface of the test specimen using the adhesive. Ensure that the plywood is

centered on the test specimen and the edges of the plywood align with the edges of the cut. Apply and cure the adhesive in accordance with the manufacturer's instructions. Prevent adhesive that drips down the side of the specimen and into the annular cut from setting by wiping clean; if setting occurs, cutting along the outline of the specimen shall be repeated. Temporarily brace the panel to the specimen as necessary to prevent slippage while adhesive cures.

6.5 Vacuum Chamber Testing:

6.5.1 Where testing is to be performed at a targeted area of suspected unbonded or debonded stucco of direct-applied portland cement-based plaster (determined through sounding or another applicable method), the area to be tested shall be a