



Designation: **B962–17** **B962 – 23**

Standard Test Methods for Density of Compacted or Sintered Powder Metallurgy (PM) Products Using Archimedes' Principle¹

This standard is issued under the fixed designation B962; the number immediately following the designation indicates the year of original adoption or, in the case of revision, the year of last revision. A number in parentheses indicates the year of last reapproval. A superscript epsilon (ϵ) indicates an editorial change since the last revision or reapproval.

This standard has been approved for use by agencies of the U.S. Department of Defense.

1. Scope*

1.1 This standard describes a method for measuring the density of powder metallurgy products that usually have surface-connected porosity.

1.2 The density of impermeable PM materials, those materials that do not gain mass when immersed in water, may be determined using Test Method **B311**.

1.3 The current method is applicable to green compacts, sintered parts, and green and sintered test specimens.

1.4 With the exception of the values for density and the mass used to determine density, for which the use of the gram per cubic centimetre (g/cm^3) and gram (g) units is the long-standing industry practice, the values in inch-pound² SI units are to be regarded as standard. The values given in parentheses are mathematical conversions to after SI units that are provided for information only and are not considered standard.

1.5 *This standard does not purport to address all of the safety concerns, if any, associated with its use. It is the responsibility of the user of this standard to establish appropriate safety and health practices and determine the applicability of regulatory limitations prior to use.*

1.6 *This international standard was developed in accordance with internationally recognized principles on standardization established in the Decision on Principles for the Development of International Standards, Guides and Recommendations issued by the World Trade Organization Technical Barriers to Trade (TBT) Committee.*

2. Referenced Documents

2.1 ASTM Standards:²

[B243 Terminology of Powder Metallurgy](#)

[B311 Test Method for Density of Powder Metallurgy \(PM\) Materials Containing Less Than Two Percent Porosity](#)

[E456 Terminology Relating to Quality and Statistics](#)

[E691 Practice for Conducting an Interlaboratory Study to Determine the Precision of a Test Method](#)

¹ These test methods are under the jurisdiction of ASTM Committee B09 on Metal Powders and Metal Powder Products and are the direct responsibility of Subcommittee B09.04 on Bearings.

Current edition approved April 1, 2017; Sept. 1, 2023. Published May 2017; September 2023. Originally approved in 2008. Last previous edition approved in 2015 as B962 – 15. DOI: 10.1520/B0962-17.17. DOI: 10.1520/B0962-23.

² For referenced ASTM standards, visit the ASTM website, www.astm.org, or contact ASTM Customer Service at service@astm.org. For *Annual Book of ASTM Standards* volume information, refer to the standard's Document Summary page on the ASTM website.

*A Summary of Changes section appears at the end of this standard

3. Terminology

3.1 Definitions of powder metallurgy (PM) terms can be found in Terminology [B243](#). Additional descriptive material is available in the Related Material section of Vol. 02.05 of the under “General Information on PM” on the Annual Book of ASTM Standards:ASTM B09 web page.

3.2 Definitions of Terms Specific to This Standard:

~~3.2.1 green density (D_g)—the mass per unit volume of an unsintered PM part or test specimen.~~

~~3.2.2 impregnated density (D_i)—the mass per unit volume of a sintered PM part or test specimen, impregnated with oil.~~

~~3.2.3 sintered density (D_s)—the mass per unit volume of a sintered, non-oil-impregnated PM part or test specimen.~~

4. Summary of Test Method

4.1 The test specimen is first weighed in air. It is then oil impregnated or some other treatment is used to seal the surface-connected porosity and the specimen is reweighed. The test specimen is then weighed when immersed in water and its density calculated based on Archimedes’ principle.

5. Significance and Use

5.1 The volume of a complex shaped PM part cannot be measured accurately using micrometers or calipers. Since density is mass per unit volume, a precise method for measuring the volume is needed. Archimedes’ principle may be used to calculate the volume of water displaced by an immersed object. For this to be applicable to PM materials that contain surface connected porosity, the surface pores are sealed by oil impregnation or some other means.

5.2 The green density of compacted parts or test pieces is normally determined to assist during press set-up, or for quality control purposes. It is also used for determining the compressibility of base powders, mixed powders, and premixes.

5.3 The sintered density of sintered PM parts and sintered PM test specimens is used as a quality control measure.

5.4 The impregnated density of sintered bearings is normally measured for quality control purposes as bearings are generally supplied and used oil-impregnated.

6. Interferences

6.1 A gain in mass when a test specimen is immersed in water is an indication that the specimen contains surface-connected porosity. Unsealed surface porosity will absorb water and cause the calculated density values to be higher than the true value.

6.2 Test specimens that contain surface-connected porosity shall be oil impregnated or have the surface-connected porosity sealed by some other means prior to their immersion in water.

7. Apparatus

7.1 *Analytical Balance*—Precision single-pan balance that will permit readings within 0.01% of the test specimen mass. See [Table 1](#). The analytical balance shall be supported in a manner to eliminate mechanical vibrations and be shielded from air drafts.

TABLE 1 Balance Readability

Mass, g	Balance Readable to, g
less than 10	0.0001
10 to less than 100	0.001
100 to less than 1000	0.01
1000 to less than 10 000	0.1

7.2 *Water*—Distilled or deionized and preferably degassed water to which 0.05 to 0.1 volume percent of a wetting agent has been added to reduce the effects of surface tension. The density of distilled water changes as a function of water temperature and therefore should be accounted for when calculating the density of the specimen. [Table 2](#).

NOTE 1—Degassing the water by evacuation, boiling, or ultrasonic agitation helps to prevent air bubbles from collecting on the test specimen and support when immersed in water.

TABLE 2 Maximum Recommended Wire Diameters

Mass, g	Wire Diameter, in. (mm)
less than 50	0.005 (0.12)
50 to less than 200	0.010 (0.25)
200 to less than 600	0.015 (0.40)
600 and greater	0.020 (0.50)

TABLE 3 Effect of Temperature on the Density of Air-Free Water^A

Temperature °F	Density (°C)	g/cm ³
59.0	(15)	0.9991
60.8	(16)	0.9989
62.6	(17)	0.9988
64.4	(18)	0.9986
66.2	(19)	0.9984
68.0	(20)	0.9982
69.8	(21)	0.9980
71.6	(22)	0.9978
73.4	(23)	0.9975
75.2	(24)	0.9973
77.0	(25)	0.9970
78.8	(26)	0.9968
80.6	(27)	0.9965
82.4	(28)	0.9962
84.2	(29)	0.9959
86.0	(30)	0.9956

TABLE 2 Effect of Temperature on the Density of Air-Free Water^A

Temperature °C	ρ_w g/cm ³	Temperature °F	ρ_w g/cm ^{3*}
15.0	0.9991	60	0.9990
15.5	0.9990	61	0.9989
16.0	0.9989	62	0.9988
16.5	0.9988	63	0.9987
17.0	0.9988	64	0.9986
17.5	0.9987	65	0.9985
18.0	0.9986	66	0.9984
18.5	0.9985	67	0.9983
19.0	0.9984	68	0.9982
19.5	0.9983	69	0.9981
20.0	0.9982	70	0.9980
20.5	0.9981	71	0.9978
21.0	0.9980	72	0.9977
21.5	0.9979	73	0.9975
22.0	0.9978	74	0.9974
22.5	0.9976	75	0.9973
23.0	0.9975	76	0.9972
23.5	0.9974	77	0.9970
24.0	0.9973	78	0.9969
24.5	0.9972	79	0.9967
25.0	0.9970	80	0.9966
25.5	0.9969	81	0.9964
26.0	0.9968	82	0.9963
26.5	0.9966	83	0.9961
27.0	0.9965	84	0.9959
27.5	0.9964	85	0.9958
28.0	0.9962	86	0.9956
28.5	0.9961		
29.0	0.9959		
29.5	0.9958		
30.0	0.9956		

*Interpolated from °C data

^A *Metrological Handbook 145*, "Quality Assurance for Measurements," National Institute of Standards and Technology, 1990, pp. 9-10.

7.3 *Water Container*—A glass beaker or other suitable transparent container should be used to contain the water.

NOTE 2—A transparent container makes it easier to see air bubbles adhering to the test specimen and specimen support when immersed in water.

NOTE 3—For the most precise density determination, the water container should be of a size that the level of the water does not rise more than 0.10 in. (2.5 mm)–2.5 mm (0.10 in.) when the test specimen is lowered into the water.

7.3 *Water*—Distilled or deionized water to which 0.05 to 0.1 volume percent of a wetting agent has been added to reduce the effects of surface tension.

NOTE 3—Degassing the water by evacuation, boiling, or ultrasonic agitation helps to prevent air bubbles from collecting on the test specimen and support when immersed in water.

7.4 *Test Specimen Support for Weighing in Water*—Two typical arrangements are shown in Fig. 1. The suspension wire may be twisted around the test specimen or the test specimen may be supported in a wire basket that is attached to the suspension wire. For either arrangement, a single corrosion-resistant wire—for example, austenitic stainless steel, copper, or nichrome—shall be used for the basket and suspension wire. ~~The~~ For the maximum recommended diameter of suspension wire to be used for various mass ranges is summarized in see Table 23.

NOTE 4—For the most precise density determinations, it is important that the mass and volume of all supporting wires immersed in water be minimized.

7.5 *Oil for Oil-Impregnation*—Oil with a viscosity of 20 to 65 cSt or 100 to 300 SSU ($20 \times 10^{-6} \text{ m}^2/\text{s}$ to $65 \times 10^{-6} \text{ m}^2/\text{s}$) at/s (20 to 100 °F (38 °C)–65 cSt (centistokes) or 100 to 300 Saybolt Universal Seconds (SUS)) at 38 °C (100 °F) has been found to be suitable.

7.5.1 In the case of oil-impregnated bearings, make an effort to match the oil that was originally used to impregnate them.

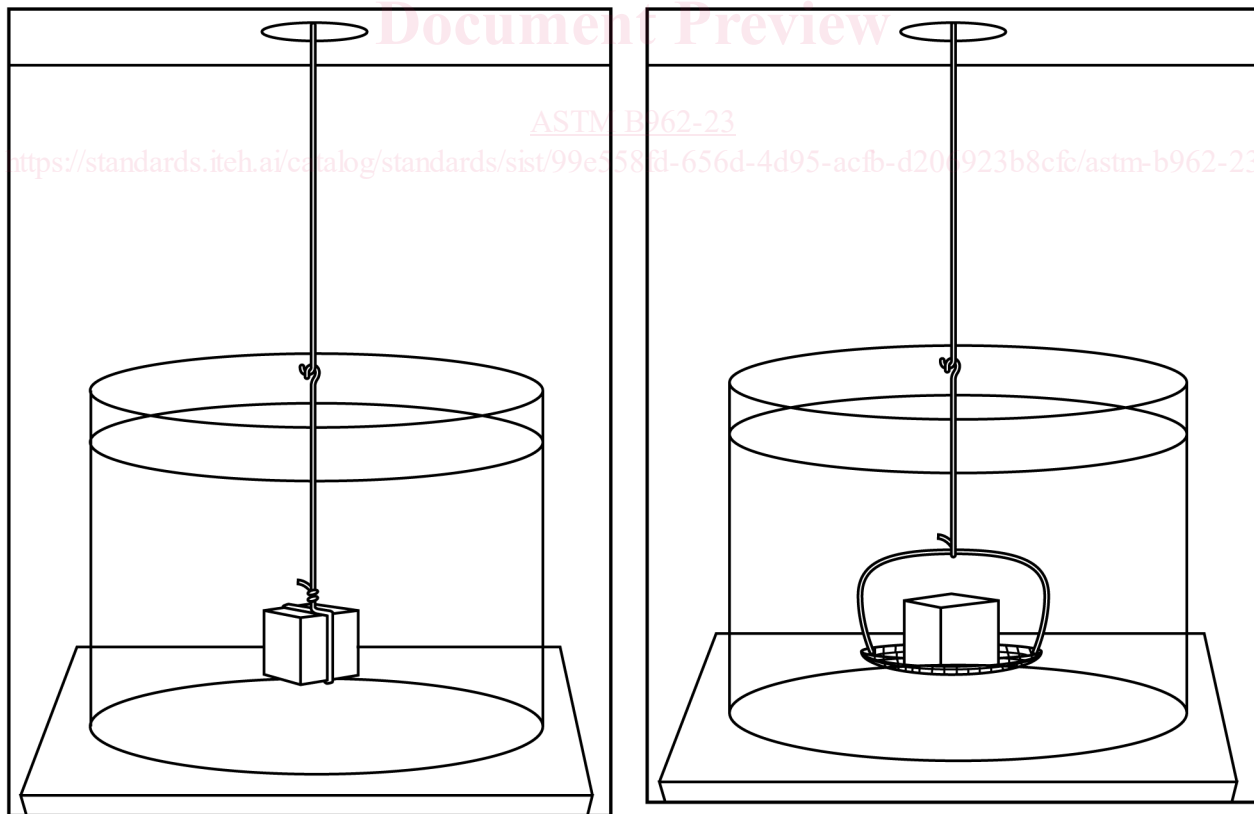

(a) Twisted wire arrangement

(b) Basket support arrangement

FIG. 1 Methods for Holding the Test Specimen When Weighing in Water

TABLE 3 Maximum Recommended Wire Diameters

Mass, g	Wire Diameter, in. (mm)
less than 50	0.12 (0.005)
50 to less than 200	0.25 (0.010)
200 to less than 600	0.38 (0.015)
600 and greater	0.50 (0.020)

7.6 *Vacuum Impregnation Apparatus*—Equipment to impregnate the part or test specimen with oil.

7.7 *Thermometer*—A thermometer with an accuracy of $\pm 0.1^\circ\text{F}$ (0.5°C) to measure the temperature of the water to the nearest 0.5°C (1°F).

8. Preparation of Test Specimens

8.1 The mass of the test specimen shall be a minimum of $\pm 0.1\text{ g}$ to 1.0 g . For small parts, several parts may be combined to reach the minimum mass.

8.2 Thoroughly clean all surfaces of the test specimen to remove any adhering foreign materials such as dirt or oxide scale. Take care with cut specimens to avoid rough surfaces to which an air bubble may adhere. A 100-grit sanding or abrasive grinding is recommended to remove all rough surfaces.

9. Procedure

9.1 The part or test specimen, the analytical balance and surrounding air shall be at a uniform temperature when weighing is performed.

9.2 For the most precise density determinations, duplicate weighings should be made for all mass measurements. Adjust the analytical balance to zero prior to each weighing. Average the mass determinations before calculating the density.

9.3 For improved repeatability and reproducibility, verify the analytical balance periodically with a standard mass that is approximately equal to the part or test specimen mass.

9.4 This standard contains three separate test methods; determination of green density, determination of sintered density, and determination of impregnated density. Each is detailed in the following sections.

Determination of Green Density

9.5 This procedure is used to determine the green density of as-compacted PM parts and test specimens. In order to determine accurately the volume of the test specimens by water displacement, the specimens shall be oil impregnated, or the pores filled with a suitable alternative material of known density. The density determined is an average of the metal additives, and any solid lubricant originally present that was used to aid compaction.

9.5.1 Determine the mass of the green part or test specimen. This is mass A. This and all subsequent weighings shall be to the precision stated in **Table 1**.

9.5.2 Oil impregnate the green part or test specimen as follows:

Preferred Vacuum Oil Impregnate—Preferred Procedure

9.5.3 Immerse the part or test specimen in oil at room temperature.

9.5.4 Reduce the pressure over the sample to $\pm 1\text{ psi}$ (7 kPa) or less for 30 minutes, then increase the pressure back to atmospheric pressure and keep the sample immersed for at least 30 minutes.

9.5.5 Remove excess oil by wiping/blotting gently with an absorbent, lint-free material. Take care not to extract oil absorbed within the part or test specimen.

9.5.6 Do not place or store parts on porous surfaces such as paper, cloth, or cardboard as these will absorb oil.

9.5.7 Proceed to [9.5.13](#).

Alternative Immersion Oil Impregnate—Alternative Procedure

9.5.8 Immerse the part or test specimen in oil at a temperature of $180 \pm 10 \text{ }^\circ\text{F}$ ($82 \pm 5 \text{ }^\circ\text{C}$) $82 \text{ }^\circ\text{C} \pm 5 \text{ }^\circ\text{C}$ ($180 \text{ }^\circ\text{F} \pm 10 \text{ }^\circ\text{F}$) for at least 4 hours:h.

9.5.9 Cool by immersing in a bath of the same oil held at room temperature and keep in this oil for at least 30 minutes:min.

9.5.10 Remove excess oil by wiping/blotting gently with an absorbent, lint-free material. Take care not to extract oil absorbed within the part or test specimen.

9.5.11 Do not place or store parts on porous surfaces such as paper, cloth, or cardboard as these will absorb oil.

9.5.12 Proceed to [9.5.13](#).

NOTE 5—It may not be necessary to oil impregnate the green part with oil. There may be enough admixed lubricant present in the surface-connected pores to prevent the absorption of water. If the test specimen gains mass when immersed in water it is an indication that the specimen contains surface-connected porosity and that it needs to be sealed by oil impregnation or some other means.

9.5.13 Determine the mass of the oil-impregnated green part or test specimen to the precision stated in [Table 1](#). This is mass B.

9.5.14 Support the container of water over the pan of the balance using a suitable bridge as shown in [Fig. 2a](#). Take care to ensure that the bridge does not restrict the free movement of the balance pan. The container of water may also be supported below the balance for weighing larger specimens if the balance has a lower beam hook for this purpose. See [Fig. 2b](#). If this arrangement is used, it is important to shield the weighing system, including the wire, from the effect of air drafts.

9.5.15 Suspend the test specimen support along with the part or test specimen from the beam hook of the balance. The water should cover any wire twists and the specimen support basket by at least 6 mm ($1/4 \text{ in.}$ (~~6 mm~~))in. to minimize the effect of surface tension forces on the weighing.

9.5.16 The test specimen support and test specimen shall hang freely from the balance beam hook, be free of air bubbles when immersed in the water, and be at the same temperature as the water and the balance.

9.5.17 The surface of the water shall be free of dust particles.

9.5.18 Weigh the part/test specimen and specimen support immersed in water. This is mass C.

9.5.19 Remove the part/test specimen from the support.

9.5.20 Weigh the test specimen support immersed in water at the same depth as before. This is mass E. The suspension support shall be free of air bubbles and the suspension wire shall not be immersed below its normal hanging depth, as a change in depth will change the measured mass.

NOTE 6—Some balances are capable of being tared. This automatically removes the necessity of reweighing the specimen support every time. In this case, tare the specimen support alone, immersed in water to the same depth as with the specimen, before weighing the specimen support and part/test specimen immersed in water. The mass of the specimen support and specimen immersed in water is mass F, which replaces mass C minus mass E.

9.5.21 Measure the temperature of the water to the nearest $2 \text{ }^\circ\text{F}$ ($1 \text{ }^\circ\text{C}$) $0.5 \text{ }^\circ\text{C}$ ($1 \text{ }^\circ\text{F}$) and record its density ρ_w , at that temperature, from [Table 32](#).

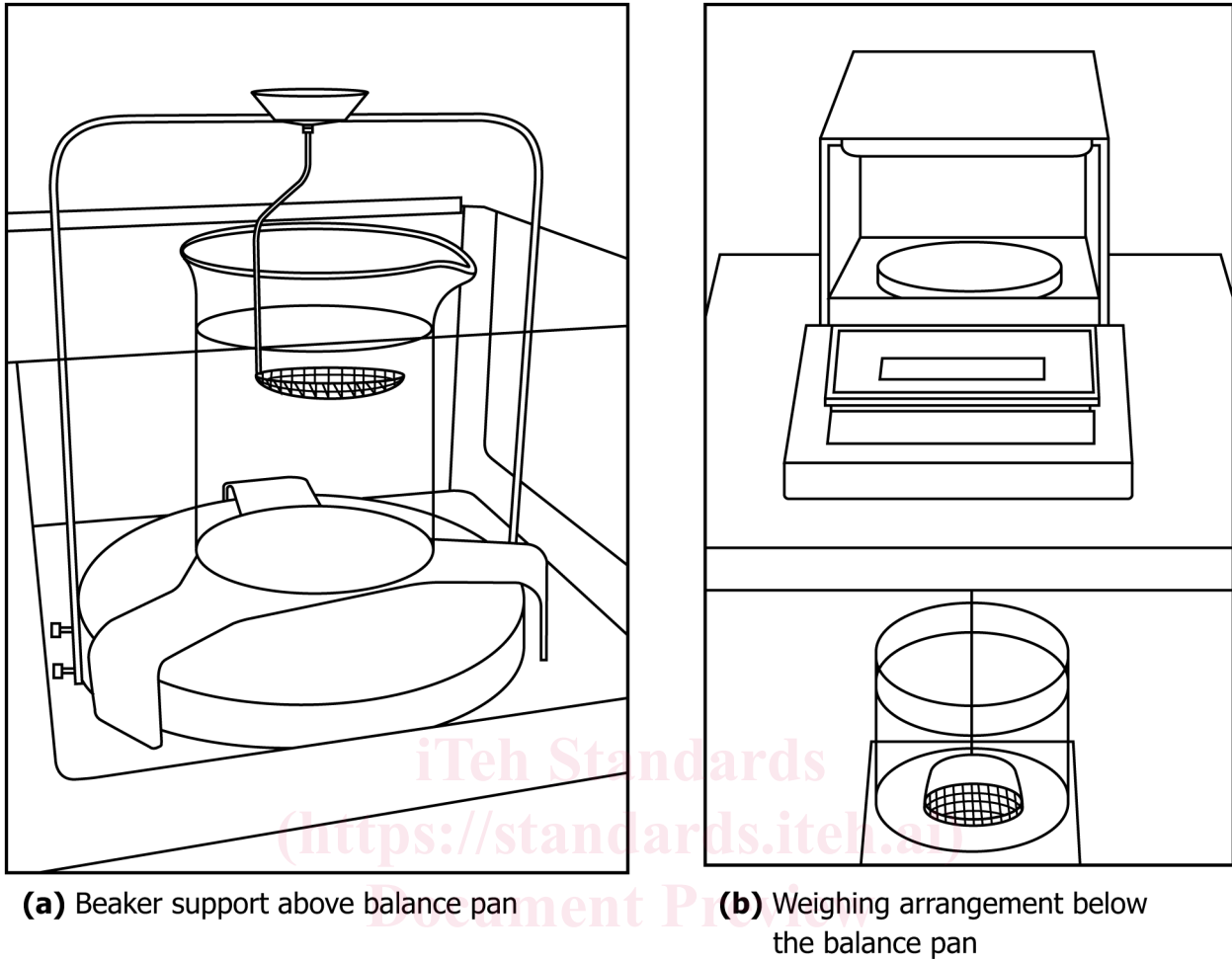

FIG. 2 Methods for Weighing in Water

<https://standards.iteh.ai/catalog/standards/sist/99e558fd-656d-4d95-acfb-d206923b8cfc/astm-b962-23>

9.5.22 Calculate the green density of a part or test piece from the following formula:

$$\text{Green Density, } D_g = \frac{A\rho_w}{B - (C - E)} \quad (1)$$

or

$$\text{Green Density, } D_g = \frac{A\rho_w}{B - F} \quad (2)$$

where:

- A = the mass of the green part or test piece in air, g;
- \bar{A} = the mass of the green (as-compacted) part or test specimen in air, g;
- B = the mass of the oil-impregnated green part or test piece, g;
- \bar{B} = the mass of the oil-impregnated green part or test specimen, g;
- C = the mass of the oil-impregnated part/test specimen and specimen support immersed in water, g;
- \bar{C} = the mass of the oil-impregnated part/test specimen support immersed in water, g;
- E = the mass of the oil-impregnated part/test specimen support immersed in water, g;
- \bar{E} = the mass of the test specimen support immersed in water, g;
- F = the mass of the oil-impregnated part/test specimen in water with the mass of the specimen support tared, g, and
- \bar{F} = the mass of the oil-impregnated part/test specimen in water with the mass of the specimen support tared, g, and
- ρ_w = the density of the water, g/cm³.
- $\bar{\rho}_w$ = the density of the water at the temperature of the test, g/cm³, and
- G = the mass of the green part or test specimen and support immersed in water, g.

If the green part did not need to be oil impregnated then use the following formula: