



Designation: F555 – 01 (Reapproved 2023)

# Standard Test Method for Motor Life Evaluation of an Upright Vacuum Cleaner<sup>1</sup>

This standard is issued under the fixed designation F555; the number immediately following the designation indicates the year of original adoption or, in the case of revision, the year of last revision. A number in parentheses indicates the year of last reapproval. A superscript epsilon ( $\epsilon$ ) indicates an editorial change since the last revision or reapproval.

## 1. Scope

1.1 This test method covers motor life evaluation of household or commercial single and dual motor upright vacuum cleaners (uprights with separate motors for creating the vacuum and driving the floor brush). Self-propelled or power-assist cleaners are not within the scope of this test method.

1.2 This test method is limited to evaluation of the upright vacuum cleaner electric motor(s).

1.3 This test method provides a test to determine operating life of the motor(s), before servicing is needed, by an accelerated laboratory procedure. Motor(s) are tested while mounted and operated in the upright vacuum cleaner.

1.4 The values stated in inch-pound units are to be regarded as standard. The values given in parentheses are mathematical conversions to SI units, which are provided for information only and are not considered standard.

1.5 *This standard does not purport to address all of the safety concerns, if any, associated with its use. It is the responsibility of the user of this standard to establish appropriate safety, health, and environmental practices and determine the applicability of regulatory limitations prior to use.*

1.6 *This international standard was developed in accordance with internationally recognized principles on standardization established in the Decision on Principles for the Development of International Standards, Guides and Recommendations issued by the World Trade Organization Technical Barriers to Trade (TBT) Committee.*

## 2. Referenced Documents

2.1 *ASTM Standards:*<sup>2</sup>

[D75 Practice for Sampling Aggregates](#)

[E337 Test Method for Measuring Humidity with a Psychrometer \(the Measurement of Wet- and Dry-Bulb Temperatures\)](#)

[F431 Specification for Air Performance Measurement Plenum Chamber for Vacuum Cleaners](#)

[F608 Test Method for Evaluation of Carpet Embedded Dirt Removal Effectiveness of Household/Commercial Vacuum Cleaners](#)

[F655 Specification for Test Carpets and Pads for Vacuum Cleaner Testing \(Withdrawn 2022\)](#)<sup>3</sup>

## 3. Terminology

3.1 *Definitions of Terms Specific to This Standard:*

3.1.1 *motor life*—limited by failure of motor. Failure is motor stoppage. In the case of a dual motor upright, the test will be continued until both motors (vacuum motor and floor brush motor) have failed. The motor that fails first will be replaced so that the test may continue on the other motor. The motor life of each motor will be recorded separately.

3.1.1.1 *Discussion*—Any failure integral with the motor, such as armature assembly, field assembly, housing(s), bearings, motor cooling fan or primary air moving fan, brush assemblies, motor mounted nonresettable thermal protection devices, or any other component judged to be integral with the motor, shall be judged as motor stoppage.

## 4. Significance and Use

4.1 The test results provide an indication of the motor life of an electric upright vacuum cleaner. End of motor life will be judged in accordance with Section 3.

## 5. Apparatus and Materials

5.1 *Voltage Regulator System*, to control the input voltage to the vacuum cleaner. The regulator system shall be capable of maintaining the vacuum cleaner's rated voltage  $\pm 1\%$  and rated frequency  $\pm 1$  Hz, having a wave form that is essentially sinusoidal with 3% maximum harmonic distortion for the duration of the test.

5.2 *Voltmeter*, to provide measurements accurate to within  $\pm 1\%$ .

<sup>1</sup> This test method is under the jurisdiction of ASTM Committee F11 on Vacuum Cleaners and is the direct responsibility of Subcommittee F11.30 on Durability-Reliability.

Current edition approved Sept. 1, 2023. Published September 2023. Originally approved in 1985. Last previous edition approved in 2016 as F555 – 01 (2016). DOI: 10.1520/F0555-01R23.

<sup>2</sup> For referenced ASTM standards, visit the ASTM website, [www.astm.org](http://www.astm.org), or contact ASTM Customer Service at [service@astm.org](mailto:service@astm.org). For *Annual Book of ASTM Standards* volume information, refer to the standard's Document Summary page on the ASTM website.

<sup>3</sup> The last approved version of this historical standard is referenced on [www.astm.org](http://www.astm.org).

5.3 *Timer and Switch*, having the capacity to control the off/on duty cycle of the cleaner during the life test.

5.4 *Sharp Edge Orifice Plate*—a 1¼-in. (32-mm) diameter orifice shall be in accordance with Fig. 2 of Specification F431.

5.5 *Wattmeter*, to provide measurements accurate to within 1 %.

5.6 *Plenum Chamber*, conforming to the plenum chamber described in Specification F431.

5.7 *Water Manometer*, or equivalent instrument measuring in increments of 0.1 in. (2.54 mm).

5.8 *Barometer*, to provide measurements accurate to ±0.05 in. Hg (1.27 mm Hg), with scale divisions 0.02 in. (0.51 mm) or finer.

5.9 *Thermometer*, having a range of at least 18 °F to 80 °F (−8 °C to +27 °C) and graduated in 1 °F (0.5 °C) increments.

5.10 *Psychrometer*, meeting the requirements of Test Method E337 for thermometers, graduated in increments of 1 °F (0.5 °C).

5.11 *Test Carpet*, conforming to the level loop carpet described in Specification F655. A carpet that provides equivalent nozzle loading results may be used.

5.12 *Carpet Padding* (optional), if used, the test carpet padding will conform to the padding described in Specification F655.

5.13 *Test Fixture*, a moving surface covered by the test carpet supported on the test pad, which moves with a horizontal reciprocating motion, for a stroke distance of 27 in. (686 mm) in each direction at the average rate of 1.8 ft/s (0.55 m/s), which results in 24 cycles (forward and back) per minute. This motion shall be generated by rotating a 13.5-in. (343-mm) radius arm, which shall be connected to the platform with an arm at least 24 in. (610 mm) long or equivalent. This device shall provide means to hold the cleaner fixed by its handle stationary in the operating position while it is in contact with the reciprocating surface (see Fig. 1). Optionally, the cleaner can be moved through the same cycle as stated above while the carpeted platform is held stationary (see Fig. 1). For either option, the reciprocating motion shall follow the same duty cycle as specified for the vacuum cleaner in 7.7. For the

optional test fixture of Fig. 1, the reciprocating arm must be at either end of its horizontal motion at the start of each “on” portion of the cycle.

5.14 *Test Dirt*, Wedron sand/talc mixture. See Annex A1.

## 6. Sampling

6.1 Test a minimum of three units (or a larger sample size if desired) of similar models using the same motor style and amperage. Select all samples at random in accordance with good statistical practice. Results shall provide an 80 % confidence level within ±10 % of the mean value. If not, test additional samples or reduce the results by the penalty factor as calculated in 7.10.

## 7. Procedure For Motor Life Evaluation

7.1 Determine initial performance as follows:

7.1.1 Seal the nozzle opening to the plenum chamber with a manometer (or equivalent) connected to the chamber and with a 1¼-in. (32-mm) diameter sharp-edge orifice in the holder. For the test, connect the agitator drive belt and a clean filter or filter bag to the cleaner. The agitator shall be operating freely with the handle in the operating position as shown in Fig. 1.

7.1.2 With the cleaner sealed to the plenum chamber and without an orifice plate in the holder, energize the cleaner at rated voltage ±1 % and rated frequency ±1 Hz for 5 min to stabilize motor temperatures.

7.1.3 With the cleaner operating at a constant rated voltage, insert the 1¼-in. (32-mm) diameter sharp-edge orifice into the holder on the orifice box.

7.1.4 Record the manometer reading as soon as the reading stabilizes.

7.1.5 Record the wattage of the cleaner on the plenum chamber. The wattage reading is used to monitor the cleaner load.

7.1.6 Measure the airflow and wattage reading every 168 h to determine if some component has failed and degraded performance, reducing the load on the cleaner during the life test. If degradation exceeds 40 % see 7.9.1 – 7.9.3.

7.1.7 Monitor the suction of the cleaner during the test in addition to the weekly measurement on the plenum chamber to maintain loading and to ensure that no mechanical problems exist.

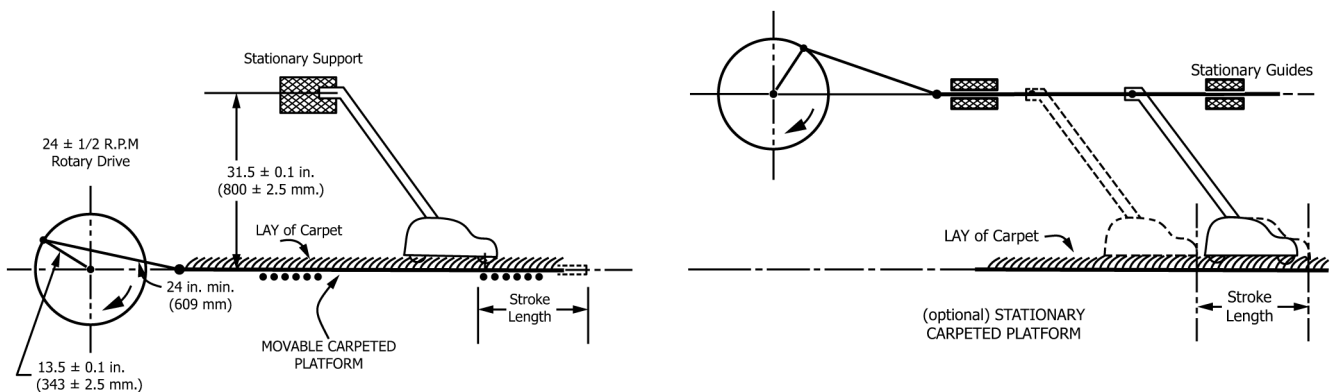

FIG. 1 Test Fixture

7.2 Use a new section of carpet and padding without holes, tears, or other signs of wear when the test is started. Tautly secure the carpet. The lay of the carpet pile shall be such that during the forward stroke, the cleaner moves in the direction of the lay of the carpet pile. See **Fig. 1**.

7.3 Install the cleaner on the test fixture as shown in **Fig. 1**.

7.4 If various settings are provided, set the motor speed setting, suction regulator, nozzle height, or a combination thereof, in accordance with the manufacturer's specified setting for using the cleaner on the level loop test carpet. The setting shall be the same as that used for Test Method **F608**.

7.5 Keep the load within limits by controlling changes in the carpet, agitator brush, drive belt, and airflow as determined in **7.5.1 – 7.5.4**.

7.5.1 Replace the carpet when one fourth of the pile height is worn away, except at the beginning and end of the stroke path.

7.5.2 During the life test, change the agitator brush(es) every 168 h of cycling time.

7.5.3 Change the drive belt every 168 h of cycling time, or if it ceases to drive the agitator on the test carpet prior to 168 h.

7.5.4 During the life test, change the disposable filter(s) or clean the reusable primary and secondary filters every 168 h of cycling time, or when the airflow decreases 40 % due to filter clogging. To determine if the filters must be changed or cleaned prior to the 168 h period, conduct an initial dust clogging test in accordance with the procedure described in **Annex A4**.

7.6 Perform all tests in a controlled ambient atmosphere with a dry bulb temperature of 68 °F to 81 °F (20 °C to 27 °C) and a relative humidity of 30 % to 50 %.

7.7 Operate the cleaner at rated voltage  $\pm 1\%$  and rated frequency  $\pm 1$  Hz from a remote on/off switch and timer with a duty cycle of 8 min of operation followed by 2 min off. During the test, bypass the switch on the cleaner.

7.8 Spread 10 g of the standard dirt mixture (**Annex A1**) at the start of the test and once every 24 h of cycling time on the test carpet. Spread evenly over the area traversed by the nozzle opening.

7.9 Test for degradation of performance every 168 h of cycling time.

7.9.1 *Airflow Loss*—In accordance with the procedure in **Annex A2**, use the suction at the start of the test in **7.1.4** as the base for determining the 40 % degradation of performance.

7.9.2 Measure suction in the operating position to serve as a base line to determine if degradation has occurred.

7.9.3 If degradation is present, determine and correct the cause. Replace any part, except the motor, to bring the system within performance limits and continue the test.

7.10 Judge the end of the test in conformance with Section **3**. Express life in terms of “on” (hours) only.

7.11 Calculate an estimate of the population mean in accordance with the following procedure:

7.11.1 Calculate the sample mean for units tested and the confidence interval half-width:

$$\bar{x} = \sum_{i=1}^n x_i \quad (1)$$

$$h = \frac{ts}{\sqrt{n}} \quad (2)$$

where:

$\bar{x}$  = mean of sample,

$n$  = sample size,

$x_i$  = life, in hours of “on” time, for each sample tested,

$h$  = half-width of confidence interval,

$t$  = value from  $t$  distribution table for 80 % ( $t_{0.90}$ ) confidence level and degrees of freedom =  $n - 1$  (see below), and

$s$  = standard deviation of sample.

Percentiles of the  $t$  Distribution

Degrees of Freedom	$t_{0.90}$
1	3.078
2	1.886
3	1.638
4	1.533
5	1.476
6	1.440
7	1.415
8	1.397
9	1.383
10	1.372
11	1.363
12	1.356
13	1.350
14	1.345
15	1.341

7.11.2 Compare the sample mean and confidence interval half-width to determine whether a penalty factor is required:

(1) If  $h \leq 0.1 \bar{x}$ , use  $\bar{x}$  as the published value.

(2) If  $h > 0.1 \bar{x}$ , test additional units to meet the confidence level, or use the following penalty factor ( $\Delta$ ):

$$\Delta = h - 0.1 \bar{x} \quad (3)$$

Use  $\bar{x} - \Delta$  as the published value.

## 8. Precision and Bias

8.1 *Precision*—A meaningful precision statement cannot be made due to the number of components in the motor, each of which could constitute failure of the motor.

8.2 *Bias*—A bias statement cannot be applied to this test method because there is no standard reference for comparison.

## 9. Keywords

9.1 durability; upright vacuum cleaner