



Designation: F2493 – 23

Standard Specification for P225/60R16 97S Radial Standard Reference Test Tire¹

This standard is issued under the fixed designation F2493; the number immediately following the designation indicates the year of original adoption or, in the case of revision, the year of last revision. A number in parentheses indicates the year of last reappraisal. A superscript epsilon (ϵ) indicates an editorial change since the last revision or reappraisal.

1. Scope

1.1 This specification covers the general requirements for the P225/60R16 97S radial standard reference test tire. The tire covered by this specification is primarily for use as a reference tire for braking traction, snow traction, and wear performance evaluations, but may also be used for other evaluations, such as pavement roughness, noise, or other tests that require a reference tire.

1.1.1 Other standard reference test tires are also used for these purposes and are referenced in Section 2.

1.2 This specification provides a 16 rim diameter code standard tire design and construction, standard dimensions, and specifies the conditions of storage.

1.3 As of 2020 the E1136 P195/75R14 92S Standard Reference Test Tire has ceased production. The F2493 P225/60R16 97S Standard Reference Test Tire is an acceptable replacement for E1136 as the reference tire for Test Methods F1805 and E1337.

1.4 The values stated in inch-pound units are to be regarded as standard. The values given in parentheses are mathematical conversions to SI units that are provided for information only and are not considered standard.

1.5 *This standard does not purport to address all of the safety concerns, if any, associated with its use. It is the responsibility of the user of this standard to establish appropriate safety, health, and environmental practices and determine the applicability of regulatory limitations prior to use.*

1.6 *This international standard was developed in accordance with internationally recognized principles on standardization established in the Decision on Principles for the Development of International Standards, Guides and Recommendations issued by the World Trade Organization Technical Barriers to Trade (TBT) Committee.*

¹ This specification is under the jurisdiction of ASTM Committee F09 on Tires and is the direct responsibility of Subcommittee F09.20 on Vehicular Testing.

Current edition approved Sept. 1, 2023. Published September 2023. Originally approved in 2006. Last previous edition approved in 2020 as F2493 – 20. DOI: 10.1520/F2493-23.

2. Referenced Documents

2.1 ASTM Standards:²

D412 Test Methods for Vulcanized Rubber and Thermoplastic Elastomers—Tension

D2240 Test Method for Rubber Property—Durometer Hardness

D3182 Practice for Rubber—Materials, Equipment, and Procedures for Mixing Standard Compounds and Preparing Standard Vulcanized Sheets

E867 Terminology Relating to Vehicle-Pavement Systems

E1136 Specification for P195/75R14 Radial Standard Reference Test Tire

E1337 Test Method for Determining Longitudinal Peak Braking Coefficient (PBC) of Paved Surfaces Using Standard Reference Test Tire

F538 Terminology Relating to Characteristics and Performance of Tires

F1805 Test Method for Single Wheel Driving Traction in a Straight Line on Snow- and Ice-Covered Surfaces

F2870 Specification for 315/70R22.5 154/150L Radial Truck Standard Reference Test Tire

F2871 Specification for 245/70R19.5 136/134M Radial Truck Standard Reference Test Tire

F2872 Specification for 225/75R16C 116/114S M+S Radial Light Truck Standard Reference Test Tire

3. Terminology

3.1 Definitions:

3.1.1 For definitions of terms used in this specification, refer to Terminology F538.

3.1.2 *all-season tread, n*—tread design providing dry, wet, and snow traction performance for an optimized balance for year-round performance and which may meet the U.S. Tire Manufacturers Association (USTMA) definition for an M&S,

² For referenced ASTM standards, visit the ASTM website, www.astm.org, or contact ASTM Customer Service at service@astm.org. For *Annual Book of ASTM Standards* volume information, refer to the standard's Document Summary page on the ASTM website.



FIG. 1 Front View of the P225/60R16 97S Radial Standard Reference Test Tire



FIG. 2 Side View of the P225/60R16 97S Radial Standard Reference Test Tire

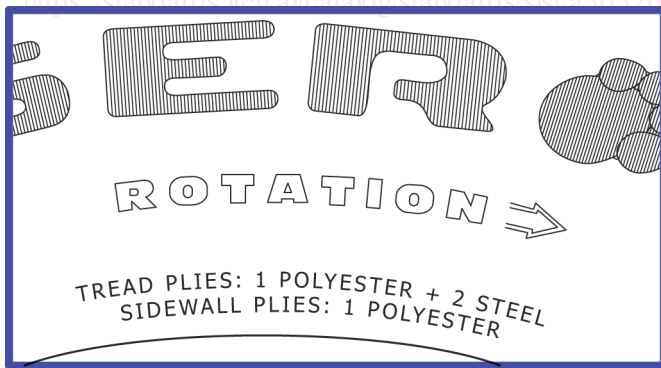

FIG. 3 Rotation Arrow

3.1.4 *pitch, n*—unit of tread pattern elements used in various combinations to obtain optimum noise levels. **F538**

3.1.5 *standard reference test tire, SRTT, n*—a tire that is commonly used as a control tire or surface monitoring tire and meets the requirements for one of Specifications E1136, F2493, F2870, F2871, or F2872. **F538**

4. Design and Construction

4.1 The P225/60R16 standard reference test tire shall feature the steel-belted radial technology, and an all-season silica content tread design, see Figs. 1 and 2, with technology as described in Section 3 and Sections 5 – 7.

4.2 The tire shall be designed to conform with the Tire and Rim Association, Inc. (TRA) standard nominal dimensions and tolerances for cross section and overall diameter found in the current TRA Yearbook.⁴

4.3 The tire used for this specification is produced by Michelin Passenger and Light Truck Tire Manufacturing.⁵ The tire is stamped on the sidewall with the words: “Standard Reference Test Tire” and ECE (Economic Commission for Europe) and DOT (Department of Transportation) certification marks.

4.4 Beginning in 2014, the tire is marked with an arrow which provides a rotational orientation for those testers who choose to reference it. (See Fig. 3.)

4.5 Beginning in 2018, the maximum inflation pressure marked on the tire sidewall is changed from 240 kPa (35 psi) to 300 kPa (44 psi).⁶

5. Materials and Manufacture

5.1 The individual standard reference test tires shall conform to the manufacturer’s design standards.

5.2 Tread compound, fabric processing, and all the steps in tire manufacturing shall be controlled to ensure minimum variability between tires.

5.3 The standard reference test tire shall be as originally molded without any tread grinding or repairs.

5.4 Since the formulation for tread compounds are proprietary, they shall be controlled by means of their physical properties given in Table 1.

⁴ Available from the Tire and Rim Association, Inc., 4000 Embassy Parkway, Suite 390, Akron, Ohio 44333, tra@us-tra.org.

⁵ The sole source of supply of the standard reference tire known to the committee at this time is Michelin Passenger and Light Truck Tire Manufacturing, 1101 Michelin Road, Ardmore, OK 73401 (specify P225/60R16 97S SRTT Uniroyal Tiger Paw AWP). If you are aware of alternative suppliers, please provide this information to ASTM International Headquarters. Your comments will receive careful consideration at a meeting of the responsible technical committee,¹ which you may attend.

⁶ The 2018 change in maximum inflation pressure accommodates a request from ISO regarding ISO 19447 “Passenger car – Methods for measuring ice grip performance – Loaded new tyres”. The F2493 SRTT is referenced with test pressure as high as 260 kPa. The revised maximum inflation pressure of 300 kPa (44 psi) was chosen to cover the pressure range specified by ISO 19447 and comply with TRA guidelines and FMVSS regulations which specify that the only approved maximum pressure values for passenger tires in the US market are 240, 280, 300, 340, or 350 kPa. Although not well described in FMVSS 139, the pressures of 240, 300, and 350 kPa have historically been standard load tire pressures and 280 and 340 kPa have been used for extra load.

M+S, M/S, MS, etc. marked tire (see USTMA “Snow Tire Definitions for Passenger and Light Truck (LT) Tires”).³ **F538**

3.1.3 *pavement characteristic, n*—physical feature or property of a pavement surface such as type, roughness, texture, and skid resistance. **E867**

³ Available from the U.S. Tire Manufacturers Association, 1400 K Street, N.W., Suite 900, Washington, D.C. 20005.

TABLE 1 Physical Properties of Tread Compound

Tensile sheet cure, min at 320°F (160°C)	15.0 min
Stress at 300 % elongation, psi (MPa)	850 ± 150 psi (5.9 ± 1.0 MPa)
Tensile strength, min psi (MPa)	2250 psi (15.5 MPa)
Elongation, min %	550 % min
Durometer hardness ^A	64 ± 2 Type A

^A Measured on tire tread.

5.5 Dimensions, weights, and permissible variations are given in Section 7.

5.6 The tire shall be of the following construction:

5.6.1 One-ply sidewall construction (polyester).

5.6.2 A three-ply tread construction (one-ply polyester and two steel belts).

5.6.3 Black sidewall.

5.6.4 Ventless tread molding.

6. Physical Properties

6.1 The physical properties of the tread compound are listed in Table 1.

7. Dimensions, Weights, and Permissible Variations

7.1 Details of dimensions are listed as follows and are shown in Fig. 4. When targets and tolerances are not specified, tire dimensions and weights are subject to manufacturer’s normal targets and tolerances.

7.2 *Inflated Dimensions and Cured Cord Angles (at 180 kPa (26 psi)):*

7.2.1 The tread width shall be 7.22 in. (183.4 mm), and the cross-sectional tread radius shall be 24.2 ± 2.0 in. (614.7 ± 50.8 mm).

7.2.2 The tread radius is measured using the three-point drop method (see Fig. 5 for an example of how the measurement is taken).

7.2.3 The tire shall have a nominal cross-section width of 9.09 in. (231.0 mm), and a nominal outside diameter of 26.76 in. (679.0 mm) when mounted on a TRA measuring rim width (16 × 6.5 J).

7.2.4 The cured cord angles shall be 90 ± 2° for the carcass and 21.0 ± 2° for the belts.



FIG. 5 Measuring the Tread Radius Using the Three-Point Drop

7.3 *Ribs*—The tire shall have five ribs.

7.4 *Grooves*—The tire shall have four circumferential grooves having a minimum groove depth of 0.314 in. (7.97 mm).

7.5 *Tread Design:*

7.5.1 *Groove (Void) Area Fraction*—37 %.

7.5.2 *Number of Pitches*—81.

7.5.3 *Footprint Size*—7.99 in. long by 6.97 in. wide (203 by 177 mm).

7.6 *Tread Wear Indicators*—The tire shall have indicators in each groove, laterally across the tread width, in six locations spaced uniformly around the tire circumference. The height of the wear indicators in the grooves shall be 0.0625 in. (1.6 mm).

NOTE 1—Groove depth is not to be measured at these wear indicators.

8. Workmanship

8.1 Tires shall be free of defects in workmanship and material.

9. Test Methods

9.1 Preparation of tensile sheet cure shall be in accordance with Practice D3182.

9.2 Stress at 300 % elongation shall be in accordance with Test Methods D412.

9.3 Tensile strength shall be in accordance with Test Methods D412.

9.4 Elongation shall be in accordance with Test Methods D412.

9.5 Tire tread hardness shall be in accordance with Test Method D2240 in addition to the following:

9.5.1 Use a Type A durometer that has the center of the presser foot at a minimum of 0.24 in. (6.0 mm) from any edge of the foot.

9.5.2 Check the durometer operation and the state of calibration of the durometer with the rubber reference block(s).

9.5.3 Condition the tire and the durometer to an equilibrium of 73.4 ± 3.6°F (23 ± 2°C) before determining the tread hardness.

9.5.4 Determine the tire tread hardness by averaging at least four readings. Take these readings in the center of each rib, excluding the center rib. It is recommended that additional sets of readings be taken around the tread circumference.

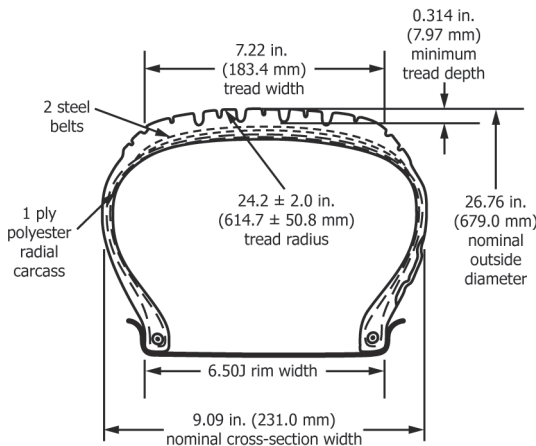

FIG. 4 Tire Cross Section