



Designation: F922 – 01 (Reapproved 2023)

Standard Test Method for Motor Life Evaluation of an Electric Motorized Nozzle¹

This standard is issued under the fixed designation F922; the number immediately following the designation indicates the year of original adoption or, in the case of revision, the year of last revision. A number in parentheses indicates the year of last reapproval. A superscript epsilon (ϵ) indicates an editorial change since the last revision or reapproval.

1. Scope

1.1 This test method covers the motorized nozzle used with household or commercial vacuum cleaner systems, that is, combination cleaners.

1.2 This test method provides a test for determining operating motor life in hours by an accelerated laboratory procedure. The motors are tested while mounted and operated in the motorized nozzle.

1.3 This test method covers only the motorized nozzle. The system used to provide the airflow source is not under consideration.

1.4 This test method is limited to the determination of motor life for an electrically powered household or commercial motorized nozzle.

1.5 The values stated in inch-pound units are to be regarded as the standard. The values given in parentheses are for information only.

1.6 *This standard does not purport to address all of the safety concerns, if any, associated with its use. It is the responsibility of the user of this standard to establish appropriate safety, health, and environmental practices and determine the applicability of regulatory limitations prior to use.*

1.7 *This international standard was developed in accordance with internationally recognized principles on standardization established in the Decision on Principles for the Development of International Standards, Guides and Recommendations issued by the World Trade Organization Technical Barriers to Trade (TBT) Committee.*

2. Referenced Documents

2.1 *ASTM Standards:*²

[D75 Practice for Sampling Aggregates](#)

¹ This test method is under the jurisdiction of ASTM Committee F11 on Vacuum Cleaners and is the direct responsibility of Subcommittee F11.30 on Durability-Reliability.

Current edition approved Sept. 1, 2023. Published September 2023. Originally approved in 1988. Last previous edition approved in 2016 as F922 – 01 (2016). DOI: 10.1520/F0922-01R23.

² For referenced ASTM standards, visit the ASTM website, www.astm.org, or contact ASTM Customer Service at service@astm.org. For *Annual Book of ASTM Standards* volume information, refer to the standard's Document Summary page on the ASTM website.

[E337 Test Method for Measuring Humidity with a Psychrometer \(the Measurement of Wet- and Dry-Bulb Temperatures\)](#)

[F431 Specification for Air Performance Measurement Plenum Chamber for Vacuum Cleaners](#)

[F608 Test Method for Evaluation of Carpet Embedded Dirt Removal Effectiveness of Household/Commercial Vacuum Cleaners](#)

[F655 Specification for Test Carpets and Pads for Vacuum Cleaner Testing \(Withdrawn 2022\)](#)³

3. Terminology

3.1 *Definitions of Terms Specific to This Standard:*

3.1.1 *motor life*—limited by failure of the motor. Failure is motor stoppage.

3.1.1.1 *Discussion*—Any failure integral with the motor such as armature assembly, field assembly, housing(s) bearings, motor cooling fan, carbon brush assemblies, motor-mounted nonresettable thermal protective devices, or any other component judged to be integral with the motor shall be judged as motor stoppage.

4. Significance and Use

4.1 The test results provide an indication of the motor life of an electric motorized nozzle. End of motor life will be judged in accordance with Section 3.

5. Apparatus and Materials

5.1 *Voltage Regulator System*, to control the input voltage to the vacuum cleaner. The regulator system shall be capable of maintaining rated voltage $\pm 1\%$ and rated frequency ± 1 Hz of the motorized nozzle, having a wave form that is essentially sinusoidal with 3% maximum harmonic distortion for the duration of the test.

5.2 *Voltmeter*, to provide measurements accurate to within $\pm 1\%$.

5.3 *Timer and Switch*, having the capacity to control the off/on duty cycle of the nozzle and air flow source during the life test.

³ The last approved version of this historical standard is referenced on www.astm.org.

5.4 *Wattmeter*, to provide measurements accurate to within 1 %.

5.5 *Sharp-Edge Orifice Plate*, a 1¼-in. (32-mm) diameter shall be in accordance with the orifice plate illustrated in Specification F431.

5.6 *Plenum Chamber*, conforming to the plenum chamber specifications in Specification F431.

5.7 *Water Manometer*, or equivalent instrument measuring in increments of 0.1 in. (2.54 mm).

5.8 *Barometer*, with an accuracy of ±0.05 in. Hg (1.27 mm Hg), capable of measuring uncorrected barometric pressure with scale divisions of 0.02 in. (0.51 mm) or finer.

5.9 *Thermometer*, having a range of at least 18 °F to 80 °F (−8°C to +27 °C) and graduated in 1 °F (0.5 °C) increments.

5.10 *Psychrometer*, meeting the requirements of Test Method E337 with thermometers graduated in increments of 1 °F (0.5 °C).

5.11 *Test Carpet*, conforming to the level loop carpet as described in Specification F655. A carpet that provides equivalent nozzle loading results may be used.

5.12 *Carpet Padding* (optional), if used, the test carpet padding will conform to the padding described in Specification F655.

5.13 *Test Cleaner or Airflow Source*—The motorized nozzle motor life evaluation tests shall be conducted using the airflow source and voltage resulting from the components which comprise the combination system with which the motorized nozzle is to be used. If used with several systems, the one with the maximum airflow shall be used.

5.13.1 *Option*—A simulated airflow source and adjusted voltage may be used if they are equal to or exceed the combination system with which the motorized nozzle is to be used.

5.14 *Test Fixture*—A moving surface, covered by the test carpet supported on the test pad, which moves with a horizontal reciprocating motion, for a stroke distance of 27 in. (686 mm) in each direction at the average rate of 1.8 ft/s (0.55 mps), which results in 24 cpm (forward and back). This motion shall be generated by rotating a 13.5-in. (343-mm) radius arm that shall be connected to the platform with an arm at least 24 in.

(610 mm) long or equivalent. This device shall provide means to hold the motorized nozzle fixed by its handle stationary in the operating position while it is in contact with the reciprocating surface.

5.14.1 *Option*—The motorized nozzle can be moved through the same cycle as stated in 5.14 while the carpeted platform is held stationary. See Fig. 1. For either option, the reciprocating motion shall follow the same duty cycle as specified for the vacuum cleaner or airflow source and motorized nozzle in 7.7. For the optional test fixture of Fig. 1, the reciprocating arm must be at either end of its horizontal motion at the start of each “on” portion of the cycle. The vacuum cleaner or airflow source shall be stationary and positioned so that the hose will be submitted to minimum stresses.

5.15 *Test Dirt*, Wedron sand/talc mixture. See Annex A1.

6. Sampling

6.1 Test a minimum of three units (or a larger sample size if desired) of similar models using the same motor style and amperage. Select all samples at random in accordance with good statistical practice. Results shall provide an 80 % confidence level within ±10 % of the mean value. If not, test additional samples or reduce the results by the penalty factor as calculated in 7.12.

7. Procedure

7.1 Determine initial performance. The suction of the cleaner or airflow source with the motorized nozzle attached is to be determined to ensure that no leaks develop to reduce load on the nozzle. For the test, the nozzle opening is to be sealed to the ASTM plenum chamber with manometer (or equivalent) connected to the chamber, and with the sharp-edge orifice plate in the holder. The motorized nozzle is to have the agitator drive belt connected and a new filter bag in the cleaner or airflow source. The agitator shall be operating freely with the handle in operating position as shown in Fig. 1.

7.1.1 With the motorized nozzle opening sealed to the plenum chamber and without an orifice plate in the holder, energize the cleaner and motorized nozzle at rated voltage 1 % and rated frequency 1 Hz for 5 min to stabilize motor temperatures. See 5.13 if an optional airflow source is used.

7.1.2 With the motorized nozzle operating at rated voltage ±1 % and rated frequency ±1 Hz and the airflow source at the

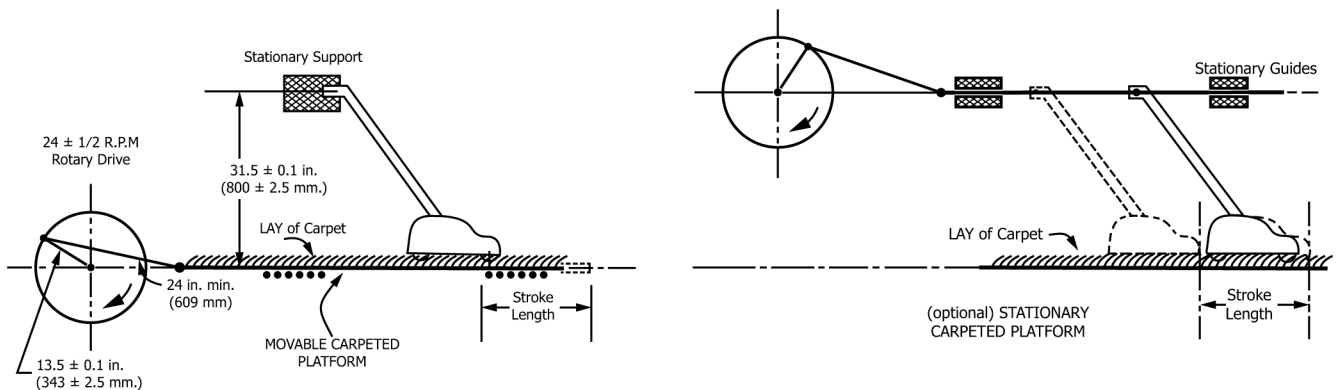

FIG. 1 Test Fixture

required voltage, insert the sharp-edge orifice plate into the holder on the orifice box, in accordance with 5.5 and 5.6.

7.1.3 Record the manometer reading of the combined power nozzle and airflow source as soon as the reading stabilizes.

7.1.4 Record the wattage of the nozzle on the plenum chamber. The wattage reading is used to monitor the nozzle load.

7.1.5 Repeat the test, recording the manometer and wattage reading of the cleaner or airflow source connected only to the plenum chamber.

7.1.6 The airflow and wattage reading shall be measured every 168 h to determine if some component has failed and degraded performance, reducing the load on the nozzle during the life test. If degradation exceeds 40 %, see 7.10.

7.1.7 Monitor the suction at the motorized nozzle daily during the test, in addition to the weekly measurement on the plenum chamber, to maintain loading and to ensure that no mechanical problems exist.

7.2 Use a new section of carpet and padding in accordance with 5.11 and 5.12 without holes, tears, or other signs of wear when the test is started. Tautly secure the carpet. The lay of the carpet pile shall be such that during the forward stroke the powered nozzle moves in the direction of the lay of the carpet pile. See Fig. 1. Measure the carpet pile height to determine carpet wear in accordance with 7.5.1.

7.3 Install the motorized nozzle on the test fixture, as shown in Fig. 1, with the nozzle connected to the airflow source.

7.4 If various settings are provided, set the motor speed, suction regulator, nozzle height, or a combination thereof, in accordance with the manufacturer’s specified setting for using the nozzle on the level loop test carpet and pad. The setting shall be the same as that used for Test Method F608.

7.5 Keep the load within limits by controlling changes in the carpet, agitator brush, drive belt, or airflow source or replacing components as determined in 7.5.1 – 7.5.4.

7.5.1 Replace the carpet when one fourth of the pile height is worn away, as measured in the center one third of the stroke, except at the beginning and end of the stroke path.

7.5.2 During the life test, change the agitator brush every 168 h of cycling time.

7.5.3 Change drive belts every 168 h of cycling time or if they cease to drive the agitator on the test carpet prior to 168 h. Replace positive drive belts if they cease to function as intended.

7.5.4 During the life test, change the disposable filter or clean the reusable primary and secondary filter every 168 h of cycling time or when the airflow decreases 40 % due to filter clogging. To determine if the filters must be changed or cleaned prior to the 168-h period, an initial dust clogging test shall be conducted in accordance with the procedure described in Annex A4.

7.6 Perform all tests in a controlled ambient with a dry-bulb temperature of 68 °F to 81 °F (20 °C to 27 °C) and with a relative humidity of 30 % to 50 %.

7.7 Operate the vacuum cleaner or airflow source (see 5.13) at a required voltage to obtain the desired airflow through the

motorized nozzle. Operate the motorized nozzle at its regulated and applicable voltage. Operate the vacuum cleaner or airflow source and motorized nozzle from a remote on-off switch and time with a duty cycle of 8 min of operation followed by 2 min off following the cycle condition set forth in 5.14.

7.8 Measure the suction of the motorized nozzle with the airflow source initially and daily on the test fixture to provide a base line for identifying if degradation has occurred. The unit can then be removed and tested on the plenum chamber to determine if it exceeds the degradation limitation in accordance with 7.11.1 and 7.11.2.

7.9 Spread 10 g of the standard dirt mixture (Annex A1) at the start of the test and once every 24 h of cycling time on the test carpet. Spread evenly over the area traversed by the nozzle opening.

7.10 Test for degradation of performance every 168 h of cycling time.

7.10.1 *Airflow Loss*—In accordance with the procedure in Annex A2, the suction at the start of the test, 7.1.3, is to be used as the base for determining the 40 % degradation of performance. Measure suction with and without the motorized nozzle to ensure degradation is in the motorized nozzle. If degradation is in the airflow source, replace or repair the airflow source and continue test. If degradation is in the motorized nozzle, determine and correct the cause. Replace or repair any part, except the motor, to bring the system within performance limits and continue the test.

7.11 Judge the end of the test in conformance with Section 3. Express life in terms of “on” time (hours) only.

7.12 Calculate an estimate of the population mean in accordance with the following procedure:

7.12.1 Calculate the sample mean for units tested and the confidence interval half-width:

$$\bar{x} = \sum_{i=1}^n x_i \quad (1)$$

$$h = \frac{ts}{\sqrt{n}}$$

where:

- \bar{x} = mean of sample,
- n = sample size,
- x_i = life, in hours of “on” time, for each sample tested,
- h = half-width of confidence interval,
- t = value from t distribution table for 80 % ($t_{0.90}$) confidence level and degrees of freedom = $n - 1$ (see below), and
- s = standard deviation of sample.

Percentiles of the t Distribution

Degrees of Freedom	$t_{0.90}$
1	3.078
2	1.886
3	1.638
4	1.533
5	1.476
6	1.440
7	1.415
8	1.397



9	1.383
10	1.372
11	1.363
12	1.356
13	1.350
14	1.345
15	1.341

Use $\bar{x} - \Delta$ as the published value.

8. Precision and Bias

8.1 *Precision*—A meaningful statement cannot be made due to the number of components in the motor, each of which could constitute failure of the motor.

8.2 *Bias*—A bias statement cannot be applied to this test method, as there is no standard reference for comparison.

9. Keywords

9.1 durability; electric motorized nozzle; standard test method; vacuum cleaner

7.12.2 Compare the sample mean and confidence interval half-width to determine whether a penalty factor is required:

(1) If $h \leq 0.1 \bar{x}$, use \bar{x} as the published value.

(2) If $h > 0.1 \bar{x}$, test additional units to meet the confidence level, or use the following penalty factor (Δ):

$$\Delta = h - 0.1 \bar{x} \quad (2)$$

ANNEXES

(Mandatory Information)

A1. DIRT MIXTURE

A1.1 Test Dirt

A1.1.1 Ten grams of the test dirt consists of the following:

90 % (wt) 9 g of silica sand⁴ and

10 % (wt) 1 g of unscented commercial-grade talcum⁵

A1.3 Analysis of Unscented Commercial-Grade Talcum

Distribution by Weight (%)	Particle Size Range (µm)
0.5	>44
12.5	20 to 43.9
27.0	10 to 19.9
23.0	5 to 9.9
20.0	2 to 4.9
8.0	1 to 1.9
9.0	<0.9

A1.2 Analysis of Silica Sand

Sieve Range (U.S. No.)	Particle Size (µm)	Amount Used (g)
-30 to +40	600 to 425	0.09
-40 to +50	425 to 300	3.15
-50 to +70	300 to 212	4.14
-70 to +100	212 to 150	1.35
-100 to +140	150 to 106	0.27

A1.4 Mixing

A1.4.1 Thoroughly mix the two dirt quantities in a suitable container-dispenser.

⁴ The sole source of supply of silica sand known to the committee at this time is Wedron No. 504 Unground Silica Sand, available from Wedron Silica Co., Customer Service Dept., P.O. Box 119, Wedron, IL 60557. If you are aware of alternative suppliers, please provide this information to ASTM Headquarters. Your comments will receive careful consideration at a meeting of the responsible technical committee, which you may attend. The test dirt must be sieved to ensure conformance with the analysis limits. Use Practice D75.

⁵ The sole source of supply for talc known to the committee at this time is USP Grade Supreme Talc, available from Luzenac America, Inc., 9000 E. Nichols Ave., Suite 200, Englewood, CO 80112. If you are aware of alternative suppliers, please provide this information to ASTM Headquarters. Your comments will receive careful consideration at a meeting of the responsible technical committee, which you may attend.