



Designation: F1601 – 01 (Reapproved 2023)

Standard Test Method for Motor Life Evaluation of an Electric Motorized Nozzle for Central Vacuum Cleaning Systems¹

This standard is issued under the fixed designation F1601; the number immediately following the designation indicates the year of original adoption or, in the case of revision, the year of last revision. A number in parentheses indicates the year of last reapproval. A superscript epsilon (ϵ) indicates an editorial change since the last revision or reapproval.

1. Scope

1.1 This test method covers the motorized nozzle used in household or commercial central vacuum cleaning systems.

1.2 This test method provides a test for determining operating motor life in hours by an accelerated laboratory procedure. The motors are tested while mounted and operated in the motorized nozzle.

1.3 This test method covers only the motorized nozzle. The system used to provide the airflow source is not under consideration.

1.4 This test method is limited to the determination of motor life for an electrically powered household or commercial motorized nozzle.

1.5 The values stated in inch-pound units are to be regarded as the standard. The values given in parentheses are for information only.

1.6 *This standard does not purport to address all of the safety concerns, if any, associated with its use. It is the responsibility of the user of this standard to establish appropriate safety, health, and environmental practices and determine the applicability of regulatory limitations prior to use.*

1.7 *This international standard was developed in accordance with internationally recognized principles on standardization established in the Decision on Principles for the Development of International Standards, Guides and Recommendations issued by the World Trade Organization Technical Barriers to Trade (TBT) Committee.*

2. Referenced Documents

2.1 *ASTM Standards:*²

[D75 Practice for Sampling Aggregates](#)

¹ This test method is under the jurisdiction of ASTM Committee F11 on Vacuum Cleaners and is the direct responsibility of Subcommittee F11.30 on Durability-Reliability.

Current edition approved Sept. 1, 2023. Published September 2023. Originally approved in 1996. Last previous edition approved in 2016 as F1601 – 01 (2016). DOI: 10.1520/F1601-01R23.

² For referenced ASTM standards, visit the ASTM website, www.astm.org, or contact ASTM Customer Service at service@astm.org. For *Annual Book of ASTM Standards* volume information, refer to the standard's Document Summary page on the ASTM website.

[E337 Test Method for Measuring Humidity with a Psychrometer \(the Measurement of Wet- and Dry-Bulb Temperatures\)](#)

[F431 Specification for Air Performance Measurement Plenum Chamber for Vacuum Cleaners](#)

[F608 Test Method for Evaluation of Carpet Embedded Dirt Removal Effectiveness of Household/Commercial Vacuum Cleaners](#)

[F655 Specification for Test Carpets and Pads for Vacuum Cleaner Testing \(Withdrawn 2022\)](#)³

3. Terminology

3.1 *Definitions of Terms Specific to This Standard:*

3.1.1 *motor life*—limited by failure of the motor; failure is motor stoppage.

3.1.1.1 *Discussion*—Any failure integral with the motor, such as armature assembly, field assembly, housing(s) bearings, motor cooling fan, carbon brush assemblies, motor-mounted non-resettable thermal protective devices, or any other component judged to be integral with the motor, shall be judged as motor stoppage.

4. Significance and Use

4.1 The test results provide an indication of the motor life of an electric motorized nozzle. The end of motor life will be judged in accordance with Section 3.

5. Apparatus and Materials

5.1 *Voltage Regulator System*—to control the input voltage to the motorized nozzle. The regulator system must be capable of maintaining the motorized nozzle's rated voltage $\pm 1\%$ and rated frequency ± 1 Hz with a wave form that is essentially sinusoidal, with 3 % maximum harmonic distortion for the duration of the test.

5.2 *Voltmeter*, to provide measurements accurate to within $\pm 1\%$.

5.3 *Timer and Switch*, having the capacity to control the off/on duty cycle of the nozzle and air flow source during the life test.

³ The last approved version of this historical standard is referenced on www.astm.org.

5.4 *Wattmeter*, to provide measurements accurate to within $\pm 1\%$.

5.5 *Sharp Edge Orifice Plate*, with a 1¼-in. (32-mm) diameter and in accordance with the orifice plate illustrated in Specification F431.

5.6 *Plenum Chamber*, conforming to the plenum chamber specifications given in Specification F431.

5.7 *Water Manometer*, or equivalent instrument, measuring in increments of 0.1 in. (2.54 mm).

5.8 *Barometer*, with an accuracy of ± 0.05 in. (1.27 mm) Hg, capable of measuring the uncorrected barometric pressure (test station pressure) with scale divisions of 0.02 in. (0.51 mm) or finer.

5.9 *Thermometer*, having a range of at least 18 °F to 80 °F (−8 °C to +27 °C) and graduated in 1 °F (0.5 °C) increments.

5.10 *Psychrometer*, meeting the requirements of Test Method E337, with thermometers graduated in increments of 1 °F (0.5 °C).

5.11 *Test Carpet*, conforming to the specifications for level loop carpet as described in Specification F655. A carpet that provides equivalent nozzle loading results may be used.

5.12 *Carpet Padding*, conforming to the padding described in Specification F655.

5.13 *Test Cleaner or Airflow Source*—The motorized nozzle motor life evaluation tests shall be conducted using the airflow source and voltage resulting from the components that compose the combination system with which the motorized nozzle is to be used. If used with several systems, the one with the maximum airflow shall be used.

5.13.1 *Option*—A simulated airflow source and adjusted voltage may be used if they are equal to or exceed the central vacuum cleaning system with which the motorized nozzle is to be used.

5.14 *Test Fixture*—A moving surface, covered by the test carpet supported on the test pad, which moves with a horizontal reciprocating motion, for a stroke distance of 27 in. (686 mm) in each direction at the average rate of 1.8 ft/s (0.55 mps), resulting in 24 cpm (forward and back). This motion shall be generated by rotating a 13.5-in. (343-mm) radius arm

that shall be connected to the platform with a suitable link (see Fig. 1). This device shall provide means to hold the motorized nozzle fixed securely by its handle in the operating position while it is in contact with the reciprocating surface. The motorized nozzle shall be restrained suitably in the horizontal operating plane yet allowed freedom of movement in the vertical plane for operation.

5.14.1 *Option*—The motorized nozzle can be subjected to the same cycle as that stated in 5.14 while the carpeted platform is held stationary (see Fig. 1).

5.14.2 For either option, the reciprocating motion shall follow the same duty cycle as that specified for the vacuum cleaner or airflow source and motorized nozzle in 7.7.

5.14.3 The motorized nozzle’s airflow source shall be stationary and positioned so that the hose will be submitted to minimum stress.

5.15 *Test Dirt*, Wedron sand/talc mixture. See Annex A1.

6. Sampling

6.1 Test a minimum of three units (or a larger sample size, if desired) of similar models using the same motor style and amperage. Select all samples at random in accordance with good statistical practice. The results shall provide an 80 % confidence level within $\pm 10\%$ of the mean value. If not, test additional samples or reduce the results by the penalty factor as calculated in 7.12.

7. Procedure for Motor Life Evaluation

7.1 Determine the initial performance. The suction of the cleaner or airflow source, with the motorized nozzle attached, is to be determined and will be used to ensure that no leaks develop to reduce load on the nozzle during the test. For this initial test, the nozzle opening is to be sealed to the ASTM plenum chamber with a manometer (or equivalent) connected to the plenum chamber. The motorized nozzle is to have the agitator drive connected and a new filter bag in the cleaner or airflow source. The agitator shall be operating freely with the handle in the operating position, as shown in Fig. 1.

7.1.1 With the motorized nozzle opening sealed to the plenum chamber and without an orifice plate in the holder, energize both the cleaner or airflow source and the motorized nozzle at its rated voltage $\pm 1\%$ and rated frequency ± 1 Hz for

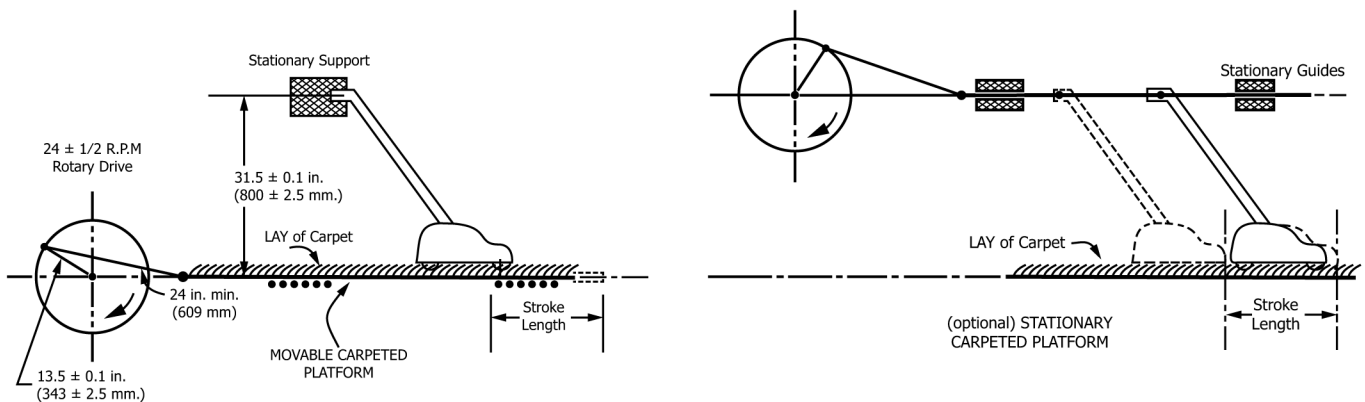

FIG. 1 Test Fixture

5 min. to stabilize motor temperatures. If either component has a dual nameplate voltage rating, conduct testing at the highest voltage.

7.1.2 With the motorized nozzle and airflow source operating at the regulated voltages of 7.1.1, insert the sharp-edge orifice plate in the holder on the orifice box, in accordance with 5.5 and 5.6.

7.1.3 Record the manometer reading of the combined power nozzle and airflow source as soon as the reading is stabilized. This manometer reading is to be used as the baseline to monitor the degradation in performance during the test.

7.1.4 Record the wattage of the motorized nozzle mounted on the plenum chamber. This wattage reading is to be used as the baseline to monitor the nozzle load during the test.

7.1.5 Repeat the initial test sequence of 7.1 – 7.4, recording manometer and wattage readings of only the cleaner or airflow source connected to the plenum chamber.

7.1.6 The airflow and wattage reading shall be measured every 168 h to determine whether some component has failed and degraded the performance, reducing the load on the nozzle during the life test. See 7.10 if the degradation exceeds 40 %.

7.1.7 Monitor the suction at the motorized nozzle daily during the test, in addition to the weekly measurement on the plenum chamber, to maintain loading and to ensure that no mechanical problems exist.

7.2 Use a new section of carpet and padding in accordance with 5.11 and 5.12 without holes, tears, or other signs of wear when the test is started. Secure the carpet tautly. The lay of the carpet pile shall be such that the motorized nozzle moves in the direction of the lay of the carpet pile during the forward stroke (see Fig. 1). Measure the carpet pile height to determine the carpet wear in accordance with 7.5.1.

7.3 Install the motorized nozzle on the test fixture, as shown in Fig. 1, with the nozzle connected to the airflow source using a hose as provided with the unit. The hose with the least resistance to airflow (smallest pressure drop) shall be used if more than one type of hose can be provided.

7.4 If various settings are provided, set the motor speed, suction regulator, nozzle height, or a combination of these, in accordance with the manufacturer’s specified setting for using the nozzle on the level loop test carpet and pad. The setting shall be the same as that used for the cleanability embedded dirt carpet test in Test Method F608.

7.5 Keep the load within limits by controlling changes in the carpet, agitator brush, drive belt, and airflow source, or by replacing the components as determined in 7.5.1 – 7.5.4.

7.5.1 Replace the carpet when one-fourth of the pile height is worn away, as measured in the center one-third of the stroke, except at the beginning and end of the stroke path.

7.5.2 Change the agitator brush every 168 h of cycling time during the life test.

7.5.3 Change the drive belts every 168 h of cycling time or if they cease to drive the agitator on the test carpet prior to 168 h. Replace the positive drive belts if they cease to function as intended.

7.5.4 During the life test, change the disposable filter or clean the reusable, primary, and secondary filter every 168 h of cycling time or when the airflow decreases 40 % due to filter clogging. To determine whether the filters must be changed or cleaned prior to the 168 h period, an initial dust clogging test shall be conducted in accordance with the procedure described in Annex A2.

7.6 Perform all tests in an ambient, having a dry bulb, temperature of 68 °F to 81 °F (20 °C to 27 °C) and with a relative humidity of 30 % to 50 %.

7.7 Operate the central vacuum cleaning system or airflow source (see 5.13) at the regulated and required voltage to obtain the desired airflow through the motorized nozzle. Operate the motorized nozzle at its regulated and applicable voltage. Operate both the vacuum cleaner or airflow source and motorized nozzle from a remote on/off switch that will control the test units to a duty cycle of 8 min of operation followed by 2 min off following the cyclic criteria set forth in 5.14.

7.8 Monitor the suction and wattage input at the motorized nozzle initially and daily on the test fixture to provide a base line for identifying whether degradation has occurred. The unit can then be removed and tested on the plenum chamber to determine whether it exceeds the degradation limitation in accordance with 7.10.1.

7.9 Spread 10 g of the standard dirt mixture (Annex A1) at the start of the test and once every 24 h of cycling time on the test carpet. Spread it evenly over the area traversed by the nozzle opening.

7.10 The airflow and wattage readings shall be measured every 168 h during the test per 7.1 – 7.1.5 to determine whether some component has failed or degraded, or both, in performance, thereby reducing the load on the nozzle or indicating failure.

7.10.1 *Air Flow Loss*—In accordance with the procedure described in Annex A2, the suction at the start of the test, as determined in 7.1.3, is to be used as the base for determining the 40 % degradation of performance. If degradation is in the airflow source, replace or repair the airflow source and continue testing. If degradation is in the motorized nozzle, determine and correct the cause. Replace or repair any part, except the motor in the motorized nozzle, to bring the system within the performance limits and continue the test.

7.11 Judge the end of the test in accordance with Section 3. Express the life in terms of “on” time in hours only.

7.12 Calculate an estimate of the population mean in accordance with the following procedure:

7.12.1 Calculate the sample mean for units tested and confidence interval, half-width, as follows: