



Designation: **C1373/C1373M – 11 (Reapproved 2017) C1373/C1373M – 23**

Standard Practice for Determination of Thermal Resistance of Attic Insulation Systems Under Simulated Winter Conditions¹

This standard is issued under the fixed designation C1373/C1373M; the number immediately following the designation indicates the year of original adoption or, in the case of revision, the year of last revision. A number in parentheses indicates the year of last reapproval. A superscript epsilon (ϵ) indicates an editorial change since the last revision or reapproval.

1. Scope

1.1 This practice presents a laboratory procedure to determine the thermal resistance of attic insulation systems under simulated steady-state winter conditions. The practice applies only to attic insulation systems that face an open attic air space.

1.2 The thermal resistance of the insulation is inferred from calculations based on measurements on a ceiling system consisting of components consistent with the system being studied. For example, such a system might consist of a gypsum board or plywood ceiling, wood ceiling joists, and attic insulation with its top exposed to an open air space. The temperature applied to the gypsum board or plywood shall be in the range of 18 to 24°C [64 to 75°F]. The air temperature above the insulation shall correspond to winter conditions and ranges from –46°C to 10°C [–51 to 50°F]. The gypsum board or plywood ceiling shall be sealed to prevent direct airflow between the warm and cold sides of the system.

1.3 This practice applies to a wide variety of loose-fill or blanket thermal insulation products including fibrous glass, rock/slag wool, or cellulosic fiber materials; granular types including vermiculite and perlite; pelletized products; and any other insulation material that is installed pneumatically or poured in place. The practice considers the effects on heat transfer of structures, specifically the ceiling joists, substrate, for example, gypsum board, air films, and possible facings, films, or other materials that are used in conjunction with the insulation.

1.4 This practice measures the thermal resistance of the attic/ceiling system in which the insulation material has been preconditioned according to the material Specifications **C549**, **C665**, **C739**, and **C764**.

1.5 The specimen preparation techniques outlined in this standard do not cover the characterization of loose-fill materials intended for enclosed applications.

1.6 This practice is to be used to characterize material behavior under controlled steady-state laboratory conditions intended to simulate actual temperature conditions of use. The practice does not simulate forced air flow conditions.

1.7 The values stated in either SI units or inch-pound units are to be regarded separately as standard. The values stated in each system may not be exact equivalents; therefore, each system shall be used independently of the other. Combining values from the two systems may result in non-conformance with the standard.

1.7.1 All values shall be reported in both SI and inch-pound units unless specified otherwise by the client.

¹ This practice is under the jurisdiction of ASTM Committee **C16** on Thermal Insulation and is the direct responsibility of Subcommittee **C16.30** on Thermal Measurement. Current edition approved May 1, 2017; Sept. 1, 2023. Published May 2017; October 2023. Originally approved in 1998. Last previous edition approved in 2014; 2017 as **C1373/C1373M – 11**; **C1373/C1373M – 11 (2017)**. DOI: 10.1520/C1373-C1373M-11R17; 10.1520/C1373-C1373M-23.

1.8 *This standard does not purport to address all of the safety concerns, if any, associated with its use. It is the responsibility of the user of this standard to establish appropriate safety and health practices and determine the applicability of regulatory limitations prior to use.*

1.9 *This international standard was developed in accordance with internationally recognized principles on standardization established in the Decision on Principles for the Development of International Standards, Guides and Recommendations issued by the World Trade Organization Technical Barriers to Trade (TBT) Committee.*

2. Referenced Documents

2.1 ASTM Standards:²

- C167 Test Methods for Thickness and Density of Blanket or Batt Thermal Insulations
- C168 Terminology Relating to Thermal Insulation
- C177 Test Method for Steady-State Heat Flux Measurements and Thermal Transmission Properties by Means of the Guarded-Hot-Plate Apparatus
- C518 Test Method for Steady-State Thermal Transmission Properties by Means of the Heat Flow Meter Apparatus
- C520 Test Methods for Density of Granular Loose Fill Insulations
- C549 Specification for Perlite Loose Fill Insulation
- C665 Specification for Mineral-Fiber Blanket Thermal Insulation for Light Frame Construction and Manufactured Housing
- C687 Practice for Determination of Thermal Resistance of Loose-Fill Building Insulation
- C739 Specification for Cellulosic Fiber Loose-Fill Thermal Insulation
- C764 Specification for Mineral Fiber Loose-Fill Thermal Insulation
- C1045 Practice for Calculating Thermal Transmission Properties Under Steady-State Conditions
- C1058 Practice for Selecting Temperatures for Evaluating and Reporting Thermal Properties of Thermal Insulation
- C1114 Test Method for Steady-State Thermal Transmission Properties by Means of the Thin-Heater Apparatus
- C1363 Test Method for Thermal Performance of Building Materials and Envelope Assemblies by Means of a Hot Box Apparatus

3. Terminology

3.1 *Definitions*— Unless otherwise stated, the definitions listed in Terminology C168 are applicable herein.

4. Significance and Use

4.1 The thermal resistance of a ceiling system is used to characterize its steady-state thermal performance.

4.2 The thermal resistance of insulation is related to the density and thickness of the insulation. Test data on thermal resistance are obtained at a thickness and density representative of the end use applications. In addition, the thermal resistance of the insulation system will be different from that of the thermal insulation alone because of the system construction and materials.

4.3 This practice is needed because the in-service thermal resistance of some permeable attic insulations under winter conditions is different, lower or higher R , than that measured at or close to simulated room temperature conditions utilizing small-scale tests in which the insulation is sandwiched between two isothermal impermeable plates that have a temperature difference (ΔT) of 20 to 30°C [36 to 54°F]. When such insulation is installed in an attic, on top of a ceiling composed of normal building materials such as gypsum board or plywood, with an open top surface exposed to the attic air space, the thermal resistance under winter conditions with heat flow up and large temperature differences is significantly less because of additional heat transfer by natural convection. Fig. 1 illustrates the difference between results from small scale tests and tests under the conditions of this practice. See Ref (1-12) for discussions of this phenomenon.³

4.4 In normal use, the thickness of insulation products ranges from 75 mm [3 in.] to 500 mm [20 in.]. Installed densities will depend upon the product type, the installed thickness, the installation equipment used, the installation technique, and the geometry of the insulated space.

4.5 The onset of natural convection under winter conditions is a function of specimen thickness for some materials. For purposes of this practice, the tests shall be carried out at thicknesses at which the product is used.

² For referenced ASTM standards, visit the ASTM website, www.astm.org, or contact ASTM Customer Service at service@astm.org. For *Annual Book of ASTM Standards* volume information, refer to the standard's Document Summary page on the ASTM website.

³ The boldface numbers in parentheses refer to the list of references at the end of this standard.

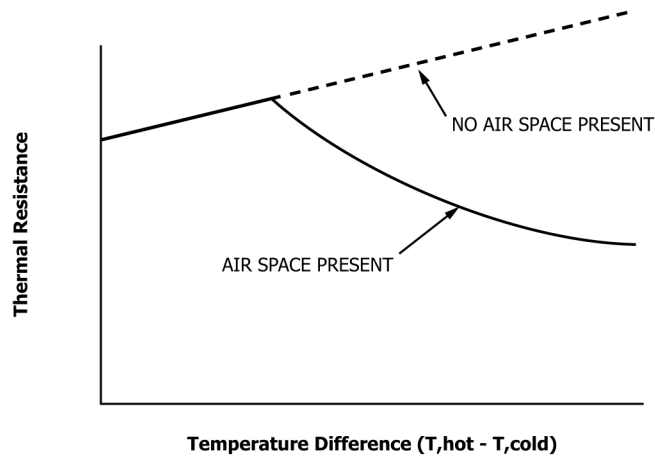

NOTE 1—A constant hot-side temperature (T_{hot}) is used for both tests and the temperature difference increases as the cold side temperature (T_{cold}) is decreased. See 5.1.6 for requirements on size of air space.

FIG. 1 Schematic of Thermal Resistance for a Permeable Attic Insulation Under Simulated Winter Conditions (Heat Flow Up)

4.6 Since this practice simulates winter conditions, the heat flow direction shall be vertically upwards.

4.7 Specimens shall be prepared in a manner consistent with the intended installation procedure. Products for pneumatic installation shall be pneumatically-applied (blown), and products for pour-in-place installation shall be poured into place. See 5.2.

5. Equipment

5.1 Thermal test apparatus used for this practice shall meet the following requirements:

5.1.1 *Conformance to Standards*—The apparatus shall conform to all requirements of the ASTM thermal test method used, except as required by 5.1.2 – 5.1.6.

5.1.2 *Size*—The apparatus shall be capable of testing specimens at the thickness intended for product use. Length and width of the metering area shall be at least twice the spacing of the wood joists or four times the specimen thickness, whichever is greater (see Fig. 2).

5.1.3 *Temperature*—The apparatus shall be capable of testing with the hot side surface maintained between 18 and 24°C [64 and 75°F], and with the cold side air temperature maintained near the winter condition for the particular climate being simulated, which ranges from –46 to 10°C [–51 to 50°F]. In the absence of specified temperatures, the ambient temperatures listed in Table 2 of C1058 on Temperatures for Thermal Transmittance Evaluations is one source of test temperatures.

NOTE 1—Only those with a hot ambient of 24°C [75°F] are applicable.

5.1.4 *Humidity*—The absolute humidity on both sides of the test apparatus shall be maintained low enough to prevent condensation within the specimen. See 6.9.6 of Test Method C1363 for humidity requirements for the hot box methods, 6.6 of Test Method C177 for the guarded hot plate method, and 7.10 of Test Method C518 for the heat flow meter apparatus.

5.1.5 *Orientation and Direction of Heat Flow*—The thermal test specimen shall be oriented horizontally with heat flow up.

5.1.6 *Thermal Test Specimen and Holder*—The test assembly shall be sized to match the test apparatus and shall be made of construction materials representative of the intended application. The substrate on which the insulation rests shall be representative of the intended application, typically gypsum board. The substrate shall be sealed to prevent direct airflow between the warm and cold sides of the system. Wood joists also shall be included. The test assembly shall be constructed such that the top of the insulation is open to an air space having a minimum thickness of 150 mm [6 in.]. Test Methods C1363 is preferred because of its ability to accommodate a large air space. Other apparatuses that simulate in-service conditions must meet the requirements of this practice, (for example, modifications of Test Methods C177, C518, or C1114 with Practice C1045). In all cases, the size

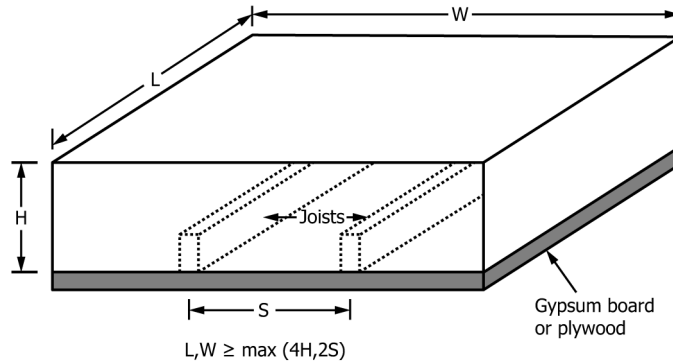

FIG. 2 Requirements on Dimensions of Test Specimen Metering Area

requirements given in 5.1.2 shall be met. Fig. 3 shows a schematic of an attic test module that has been used for these types of tests. Other configurations without the roof structure are acceptable as long as the minimum 150 mm [6 in.] air space is maintained.

5.2 Specimen Preparation Equipment:

5.2.1 *Blowing Apparatus*—A blowing apparatus is required when pneumatically-applied specimens are to be tested. Choose the combination of hopper, blower, hose size and length that is representative of common use for the application of the material to be tested. The following machine specifications have been developed for use with mineral fiber and cellulosic materials.

5.2.1.1 A commercial blowing machine with a design capacity for delivering the subject material at a rate recommended by the insulation manufacturer shall be used. The machine must utilize 46 m [150 ft] of flexible, internally corrugated blowing hose with an appropriate sized diameter as specified by the machine manufacturer. At least 30 m [100 ft] of the hose must be elevated between 3 and 6 m [10 and 20 ft] above the blowing machine to simulate typical installation configuration. The hose must have no more than eight 90° bends and no bends less than 1.2 m [4 ft] radius. It is good practice to clean the hose periodically by mechanically agitating it with the blower operating. This practice dislodges any pieces of old insulation that might be caught in the hose.

6. Sampling

6.1 A sample of material shall be selected from a lot according to sampling plans given in the material specifications, regulations, or other appropriate documents when applicable. In the absence of such directions, material from at least two randomly chosen packages shall be combined in equal portions (mass) so as to combine materials as uniformly as practicable.

6.2 The insulation material is preconditioned to a moisture content in equilibrium with the laboratory conditions prior to the specimen installation. Preconditioning of materials not only ensures controlled installation conditions but reduces the time required to condition the prepared specimen prior to thermal testing. For conditioning requirements, see the applicable materials Specifications C520, C549, C665, C739, and C764.

7. Specimen Preparation

7.1 General Instructions:

7.1.1 All specimens shall be prepared to a thickness and unit area mass that are given for the label *R*-value specification of interest for the material under test.

7.1.2 Specimens shall be prepared in a manner consistent with the intended installation procedure. All materials shall be installed carefully using the manufacturer's recommended installation practice. Batts shall be cut, as required, to fit the available specimen holder. Products for pneumatic installation shall be pneumatically-applied (blown), and products for pour-in-place installation shall be poured into the specimen holder. See 7.2.2 for the density of pneumatically-installed insulation. Other materials must be installed at the density suggested by the manufacturer.

7.1.3 The specimen holder shall represent typical attic frame construction, wherever possible. This requires, as a minimum, horizontal members representing the bottom chord of a truss system or rafter framing and an air-tight gypsum board or plywood bottom. The specimen holder shall be clean and free of insulation residue prior to installation of the sample insulation.

LARGE SCALE CLIMATE SIMULATOR

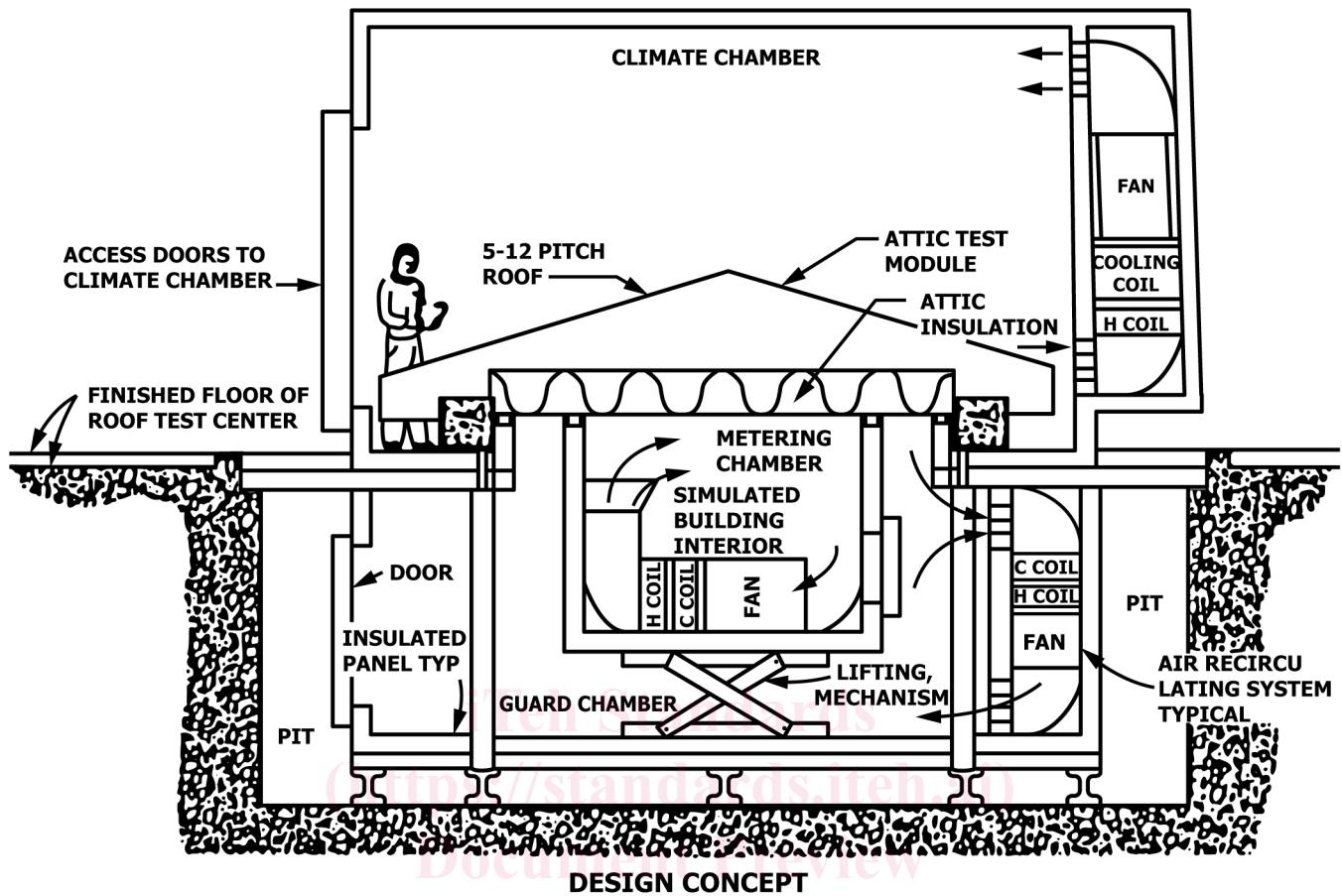

FIG. 3 Schematic of Attic Test Module and Large Scale Climate Simulator Used for Tests on Attic Insulation Under Simulated Winter Conditions

ASTM C1373M-23

<https://standards.iteh.ai/catalog/standards/sist/3ba60c63-21ae-4a95-998d-cca047fb2bd6/astm-c1373-c1373m-23>

NOTE 2—For commonly available loose-fill insulation, state and federal energy codes, ASTM material specifications and the Federal Trade Commission have identified those materials that shall apply a correction for settling when determining thermal performance. It is beyond the scope of this practice to outline the procedures for this determination.

NOTE 3—Many factors can influence the characteristics of the loose-fill insulation. These include blowing rate, machine adjustments, the size and length of the hose, and the angle and dimensions of the hose outlet in relation to the specimen holder. Trained operators are required to duplicate field-installed conditioning.

NOTE 4—For these tests, the specimen shall be blown close to the labeled density. Some operators may wish to establish a target mass of insulation required to fill the test frame to the desired thickness and density as a control during the specimen preparation process. By weighing the initial material and that remaining after blowing is complete, the operator can estimate the material in the test frame. Other operators may wish to eliminate these extra steps. The reported test density, however, is obtained from the metering area density measurement conducted after the thermal test.

7.2 Specimen Preparation—Pneumatic-Application:

7.2.1 The procedure described in this section is intended for all products, which normally are installed pneumatically. For materials exhibiting post installation settling, a supplemental instruction set is provided in 7.3 to correct the test specimen blown density to accommodate for in-situ settling after installation.

7.2.2 *Installed Density*—The thermal resistances of loose-fill insulations are specified using densities selected by manufacturers to represent the product settled densities. Generally, it is necessary to know the product thermal resistance at a representative density. Some bag labels utilize multiple densities to reflect the fact that greater thickness installations usually result in higher installed densities. The use of multiple densities is detected from the bag label by calculating the label density for several different R-value levels. Label densities for a given R-value are calculated from the bag label by dividing the minimum mass/unit area by

the minimum thickness. If the calculated densities are significantly different, the multiple density label has been used. When applicable specifications or codes do not specify the density to be used for comparison purposes, the recommended practice is to use the R-30 label density ($R(SI) = 5.3 \text{ m}^2 \cdot \text{K/W}$). If the density is not available from the bag label, a density for test purposes is established by the procedures outlined in Test Method **C520** or Specification **C739**.

7.2.3 Calculate the target mass of insulation required to fill the sample frame to the target thickness and density from the equation:

$$m = \rho [(L_{\text{ins}} \times A) - V_{\text{joist}}] \quad (1)$$

where:

m = target mass of insulation, kg [lb],
 ρ = target density, kg/m³ [lb/ft³],
 L_{ins} = target insulation thickness, m [ft],
 A = area within sample frame, m² [ft²], and
 V_{joist} = volume of joists within frame area, m³ [ft³].

7.2.4 Assemble the blowing machine, hose and hose length combination as appropriate for the material being prepared.

7.2.5 Set the blowing machine adjustments and select the feed rates in accordance with the insulation manufacturer's recommendations. If the insulation manufacturer does not provide this information, consult the machine manufacturer for recommended settings.

7.2.6 Place the required amount of insulation material (7.2.3) into the blowing machine hopper. If the hopper is too small to hold the entire amount required, fill the hopper to capacity with the premixed insulation (see 6.1). Additional material is added as required during the blowing process until the total amount of needed insulation is blown.

7.2.7 Turn on the blowing machine with the hose outlet directed away from the center of the specimen metering area and toward the far end of the specimen holder. The hose outlet orientation is varied, side to side, as needed to cover uniformly the entire area of the specimen holder, but shall remain approximately horizontal.

NOTE 5—Since the insulation material has been premeasured, some means of limiting the loose-fill trajectory to within the sample frame is required. A screen tent arrangement has been found effective in performing this operation.

7.2.8 Blow insulation into the specimen holder from the far end to approximately the middle line of the holder. Then move the hose to the opposite end of the specimen holder and blow the remainder of the holder with insulation. The direction from which the insulation is blown is alternated several times during the blowing period in order to provide as nearly uniform coverage of the specimen holder as possible while obtaining the desired thickness and mass.

NOTE 6—A new specimen shall be prepared if the intent is to test at label thickness and density, but the specimen exceeds the upper mass without reaching the target thickness or exceeds the upper thickness limit without meeting the target mass.

NOTE 7—Care should be observed when handling or moving the filled specimen holder so as not to disturb the test specimen any more than is absolutely necessary. Any vibration or impact can change the pack structure of the blown specimen and change its thermal properties.

7.2.9 Use a rake or piece of stiff wire to level the top surface of the specimen taking care not to disturb the subsurface material.

7.3 *Pneumatic Application—Settled Density Correction:*

7.3.1 The procedure listed below is required for those materials where the specimen preparation shall be modified to accommodate a correction for settling after installation. See **Note 2** following 7.1.3.

7.3.2 Prepare the insulation specimen as directed in 7.2.

7.3.3 Using the mass of the insulation material in the specimen holder, determine the required test thickness that provides the final product settled density.

7.3.4 Uniformly compress the insulation material using a large flat board or paddle to establish the targeted test thickness determined in 7.3.3.