



Standard Practice for Measuring the Uniformity of Furnace Exposure on Test Specimens¹

This standard is issued under the fixed designation E2749; the number immediately following the designation indicates the year of original adoption or, in the case of revision, the year of last revision. A number in parentheses indicates the year of last reapproval. A superscript epsilon (ϵ) indicates an editorial change since the last revision or reapproval.

1. Scope

1.1 This standard provides general principles for measuring the uniformity of the furnace exposure on specimens tested in accordance with Test Methods E119, E814, E1529, E1725, E1966 and E2336.

1.2 This practice specifies the materials and the construction requirements for a standardized test specimen used to provide a mounting surface for the instrumentation that measures furnace exposure.

1.3 The instrumentation records temperatures, pressure differentials, and oxygen content near the exposed surface of the test specimen.

1.4 The values stated in SI units are to be regarded as the standard. The units given in parentheses are for information only.

1.5 *This standard is used to measure and describe the response of materials, products, or assemblies to heat and flame under controlled conditions, but does not by itself incorporate all factors required for fire hazard or fire risk assessment of the materials, products, or assemblies under actual fire conditions.*

1.6 *Fire testing is inherently hazardous. Adequate safeguards for personnel and property shall be employed in conducting these tests.*

1.7 *This standard does not purport to address all of the safety concerns, if any, associated with its use. It is the responsibility of the user of this standard to establish appropriate safety, health, and environmental practices and determine the applicability of regulatory limitations prior to use.*

1.8 *This international standard was developed in accordance with internationally recognized principles on standardization established in the Decision on Principles for the Development of International Standards, Guides and Recom-*

mendations issued by the World Trade Organization Technical Barriers to Trade (TBT) Committee.

2. Referenced Documents

2.1 *ASTM Standards:*²

C1396/C1396M Specification for Gypsum Board
E119 Test Methods for Fire Tests of Building Construction and Materials

E176 Terminology of Fire Standards

E814 Test Method for Fire Tests of Penetration Firestop Systems

E1529 Test Methods for Determining Effects of Large Hydrocarbon Pool Fires on Structural Members and Assemblies

E1725 Test Methods for Fire Tests of Fire-Resistive Barrier Systems for Electrical System Components

E1966 Test Method for Fire-Resistive Joint Systems

E2336 Test Methods for Fire Resistive Grease Duct Enclosure Systems

2.2 *ISO Standard:*³

ISO 834-2 Fire resistance tests – Elements of building construction – Part 2: Guide on measuring uniformity of furnace exposure on test samples

3. Terminology

3.1 *Definitions*—For definitions of terms used in this practice, refer to Terminology E176.

3.2 *Definitions of Terms Specific to This Standard:*

3.2.1 *effective area of the furnace opening, n*—furnace opening within the boundaries of the monitoring instrumentation.

4. Summary of Practice

4.1 This practice consists of preparing a standardized test specimen to represent test specimens described in Test Methods E119, E814, E1529, E1725, E1966 and E2336. The

¹ This practice is under the jurisdiction of ASTM Committee E05 on Fire Standards and is the direct responsibility of Subcommittee E05.11 on Fire Resistance.

Current edition approved Oct. 1, 2023. Published October 2023. Originally approved in 2010. Last previous edition approved in 2019 as E2749 – 15a (2019). DOI:10.1520/E2749-23.

² For referenced ASTM standards, visit the ASTM website, www.astm.org, or contact ASTM Customer Service at service@astm.org. For *Annual Book of ASTM Standards* volume information, refer to the standard's Document Summary page on the ASTM website.

³ Available from International Organization for Standardization (ISO), ISO Central Secretariat, Chemin de Blandonnet 8, CP 401, 1214 Vernier, Geneva, Switzerland, <https://www.iso.org>.

standardized test specimen provides a low cost, easily constructed supporting construction for the mounting of instrumentation that measures the exposure imposed by the furnace onto test specimens.

4.2 The standardized test specimen consists of two layers of 15.9 mm (5/8 in.) thick Type X gypsum board on the surface facing the furnace chamber attached to steel channels and a single layer of structural panels (plywood or oriented strand board) attached to the steel channels on the surface away from the furnace chamber. The gypsum board provides a fire-resistant surface for the mounting of the instrumentation. The structural panels provide stability for the steel support channels.

4.3 Instrumentation to measure the thermal impact due to exposure to the furnace upon the standardized test specimen is installed at various locations on the exposed surface of the standardized test specimen. Probes used to gather air samples within the furnace chamber are also installed.

4.4 The standardized test specimen is exposed to the time-temperature curve specified in referenced ASTM fire test standards for a time period of 45 min during which time data are recorded by the instrumentation mounted on the standardized test specimen.

4.5 The data provide a record of the conditions and uniformity of the furnace exposure upon standardized test specimens. The area bounded by the instrumentation installed on the standardized test specimen is designated as the effective area of the furnace opening.

5. Significance and Use

5.1 This practice describes a procedure to gather data intended to measure the uniformity of exposure conditions upon test specimens for the fire test methods described in Test Methods E119, E814, E1529, E1725, E1966 and E2336. The collected data from furnaces are intended to form a basis for performance requirements for the furnaces described in the referenced standards.

5.2 This practice does not include requirements for furnace performance.

5.3 In this procedure, the standardized test specimen is subjected to one or more specific sets of laboratory test conditions. If different test conditions are substituted or the end-use conditions are changed, it is not always possible by or from this procedure to predict changes in the fire-test-response characteristics measured. Therefore, the results are valid only for the fire-test-exposure conditions described in this procedure.

5.4 The attention of all persons connected with the conduct of this practice is drawn to the fact that fire testing is hazardous and that there is a possibility that harmful smoke and gases are developed during the test. There is also a possibility that mechanical and operational hazards develop during the construction of the test specimen and the disposal of the test residues. An assessment of all potential hazards and risks to health shall be made and safety precautions shall be identified and provided. Written safety instructions shall be issued.

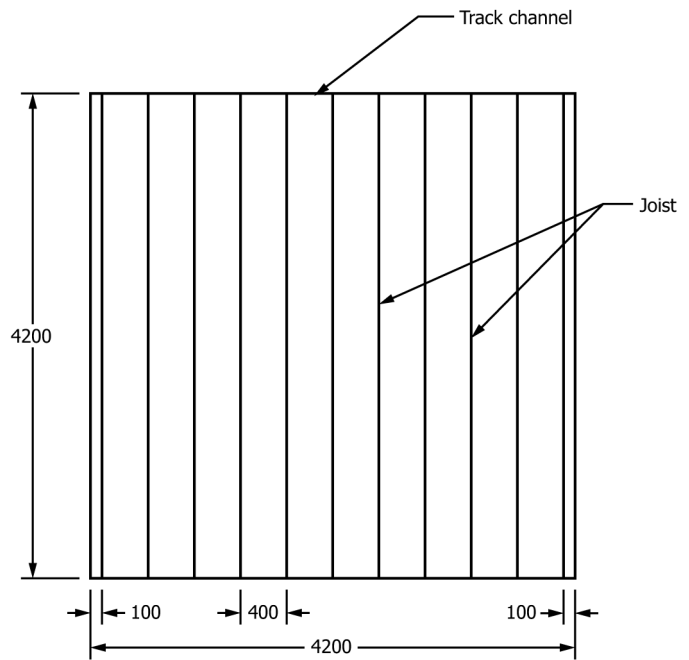

Dimensions in millimetres.

FIG. 1 Horizontal Standardized Test Specimen, Location of Joists and Track Channels

Appropriate training shall be provided to relevant personnel. Laboratory personnel shall ensure that they follow written safety instructions at all times.

6. Apparatus

6.1 The furnace(s) and restraining frame(s) used to conduct tests in accordance with Test Methods E119, E814, E1529, E1725, E1966 and E2336 shall be used.

6.2 Standardized Test Specimen:

6.2.1 *Materials*—The materials used to construct the standardized test specimen shall consist of the following: gypsum board, structural panels, cold-formed steel supports and fasteners.

6.2.1.1 The gypsum board shall be minimum 15.9 mm (5/8 in.) thick complying with the requirements of Type X as defined in Specification C1396/C1396M.

6.2.1.2 The structural panels shall be minimum 18 mm (nominal 3/4 in.) thick. Typical materials include plywood and oriented strand boards.

6.2.1.3 The cold-formed steel joists for horizontal specimens shall be fabricated from minimum 1.4 mm thick (0.055 in.) steel. The cold formed steel joists shall be “C” shaped having a minimum depth of 240 mm (9 1/2 in.), a minimum flange width of 40 mm (1 5/8 in.) and a minimum lip length of 12 mm (1/2 in.).

6.2.1.4 The cold-formed steel wall studs for vertical specimens shall be fabricated from minimum 0.9 mm thick (0.035 in.) steel. The cold-formed steel wall studs shall be “C” shaped having a minimum depth of 90 mm (3 1/2 in.), a minimum flange width of 30 mm (1 1/4 in.) and a minimum folded back return flange legs of 5 mm (1/4 in.).

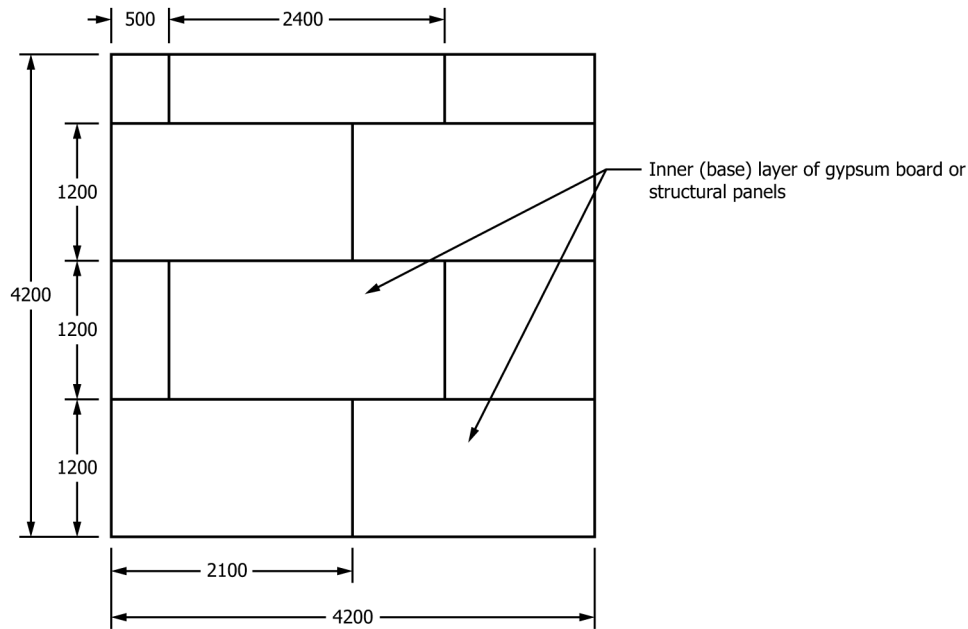

Dimensions in millimetres.

FIG. 2 Horizontal Standardized Test Specimen, Location of Inner Layer of Gypsum Board and Structural Panels

6.2.1.5 The cold-formed steel track channels for the horizontal and vertical specimens shall be “C” shaped having a depth compatible with the joists or wall studs being used.

6.2.1.6 Steel fasteners used to attach the gypsum board to the studs shall be designed for the attachment of gypsum board to steel supports. Typical screws have a thread diameter of 5 mm (1/4 in.) and a head diameter of 8 mm (3/8 in.). The steel fasteners used to attach the inner layer shall have a minimum length of 25 mm (1 in.). The steel fasteners used to attach the exposed layer shall have a minimum length of 40 mm (1 5/8 in.).

6.2.1.7 Fasteners used to attach the structural panels to the studs shall be designed for the attachment of the panels to steel supports.

6.2.2 *Construction Method*—Horizontal Standardized Test Specimen.

6.2.2.1 The construction details with respect to the location of the joists, track channels, gypsum board and the structural panels are shown in Figs. 1-3. The construction details assume a furnace opening of 4.2 m by 4.2 m (13 ft 9 3/8 in. by 13 ft 9 3/8 in.). Modifications to dimensions are necessary for other furnace openings.

6.2.2.2 The steel joists shall be spaced 300 mm to 450 mm (11 7/8 in. to 17 3/4 in.) on center. The joists are inserted into the track channels. The use of steel clip angles are permissible to facilitate the attachment of the joists to the track channels.

6.2.2.3 The inner layer of gypsum board shall be attached to the joists with the steel screws spaced a maximum of 200 mm (7 7/8 in.) on center along each joist. A distance of 10 mm to 15 mm (3/8 in. to 5/8 in.) shall be provided between the screws and the edges of the gypsum board.

NOTE 1—The inner layer, or base layer, of gypsum board is in contact with the joists.

6.2.2.4 The exposed layer of gypsum board shall be attached to the joists with steel screws spaced a maximum

200 mm (7 7/8 in.) on center along each joist and shall be spaced 100 mm (4 in.) from the screws used to attach the inner layer. A distance of 10 mm to 15 mm (3/8 in. to 5/8 in.) shall be provided between the screws and the edges of the gypsum board.

NOTE 2—The exposed layer, or outside layer, of gypsum board is in contact with the inner layer of gypsum board.

6.2.2.5 The structural panels shall be attached to the joists with steel screws spaced a maximum of 150 mm (5 7/8 in.) on center along each joist. A distance of 10 mm to 15 mm (3/8 in. to 5/8 in.) shall be provided between the screws and the edges of the structural panels. Holes are permissible in the structural panels to facilitate the installation of the instrumentation.

6.2.3 *Construction Method*—Vertical Standardized Test Specimen:

6.2.3.1 The construction details with respect to the location of the wall studs, track channels, gypsum board and the structural panels are shown in Figs. 4-6. The construction details assume a furnace opening of 3.1 m by 3.1 m (10 ft 2 in. by 10 ft 2 in.). Modifications to dimensions are necessary for other furnace openings.

6.2.3.2 The wall studs shall be spaced 300 mm to 450 mm (11 7/8 in. to 17 3/4 in.) on center. The studs are inserted into track channels. The use of steel clip angles are permissible to facilitate the attachment of the studs to the track channels.

6.2.3.3 The inner layer of gypsum board shall be attached to the studs with the steel screws spaced a maximum of 200 mm (7 7/8 in.) on center along each stud. A distance of 10 mm to 15 mm (3/8 in. to 5/8 in.) shall be provided between the screws and the edges of the gypsum board.

NOTE 3—The inner layer, or base layer, of gypsum board is in contact with the studs.

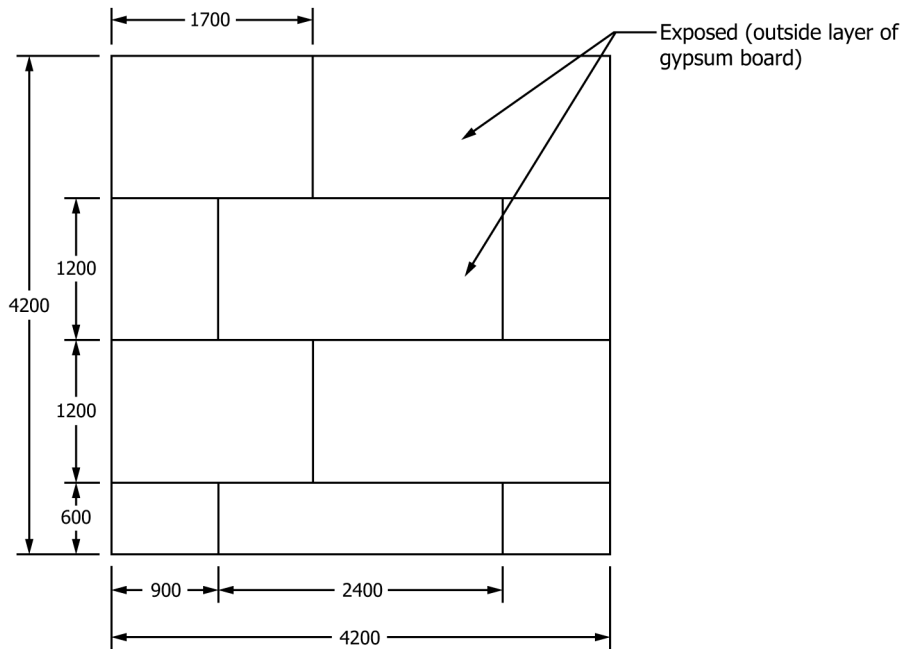

Dimensions in millimetres.

FIG. 3 Horizontal Standardized Test Specimen, Location of Outer Layer of Gypsum Board

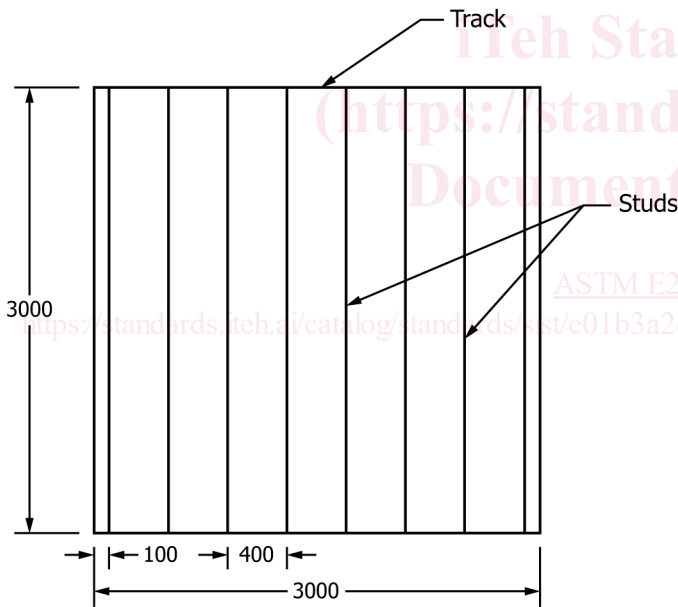

Dimensions in millimetres.

FIG. 4 Vertical Standardized Test Specimen, Location of Wall Studs and Track Channels

6.2.3.4 The exposed layer of gypsum board shall be attached to the studs with steel screws spaced a maximum 200 mm (7⁷/₈ in.) on center along each stud and shall be spaced 100 mm (4 in.) from the screws used to attach the inner layer. A distance of 10 mm to 15 mm (³/₈ in. to ⁵/₈ in.) shall be provided between the screws and the edges of the gypsum board.

NOTE 4—The exposed layer, or outside layer, of gypsum board is in contact with the inner layer of gypsum board.

6.2.3.5 The structural panels shall be attached to the support channels with steel screws spaced a maximum of 150 mm (5⁷/₈ in.) on center along each support channel. A distance of 10 mm to 15 mm (³/₈ in. to ⁵/₈ in.) shall be provided between the screws and the edges of the structural panels. Holes are permissible in the structural panels to facilitate the installation of the instrumentation.

6.3 Furnace Limitations—Furnaces with dedicated applications, such as testing of ceiling assemblies, typically have specific horizontal or vertical assemblies for this purpose and therefore do not include open restraining frames.

6.3.1 It is permissible to modify the standardized test specimen to account for these limitations.

6.4 Instrumentation—The instrumentation installed on the standardized test specimen shall include plate thermometers, a directional flame thermometer, bi-directional probes, Type K thermocouples and air sampling probes.

6.4.1 The plate thermometers (1)⁴ shall be constructed as shown in Fig. 7.

6.4.1.1 The plate part of the plate thermometer shall be constructed from 150 mm ± 1 mm long by 100 mm ± 1 mm wide by 0.7 mm ± 0.1 mm thick nickel alloy plate strips folded to the design shown in Fig. 7.

6.4.1.2 A Type K ungrounded Inconel⁵ sheathed thermocouple having a maximum diameter of 1 mm shall be fixed to the geometric center of the plate in the position shown in Fig. 7 by a steel strip made from the same material as the plate. The steel strip shall be welded or screwed to the plate. The strip shall be 18 mm ± 1 mm by 6 mm ± 1 mm when it is spot

⁴ The boldface numbers in parentheses refer to a list of references at the end of this standard.

⁵ Inconel is a registered trademark of Special Metals Corporation.

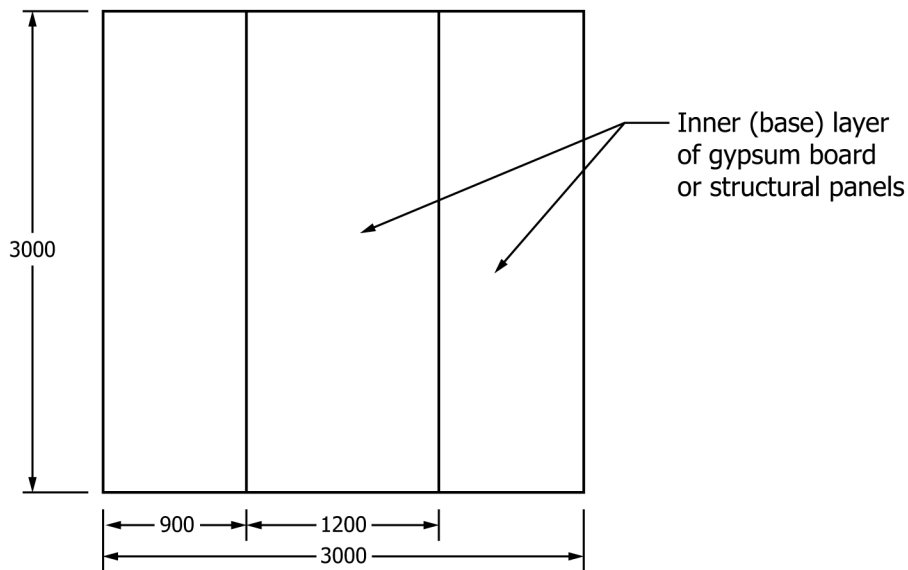

Dimensions in millimetres.

FIG. 5 Vertical Standardized Test Specimen, Location of Inner Layer of Gypsum Board and Structural Panels

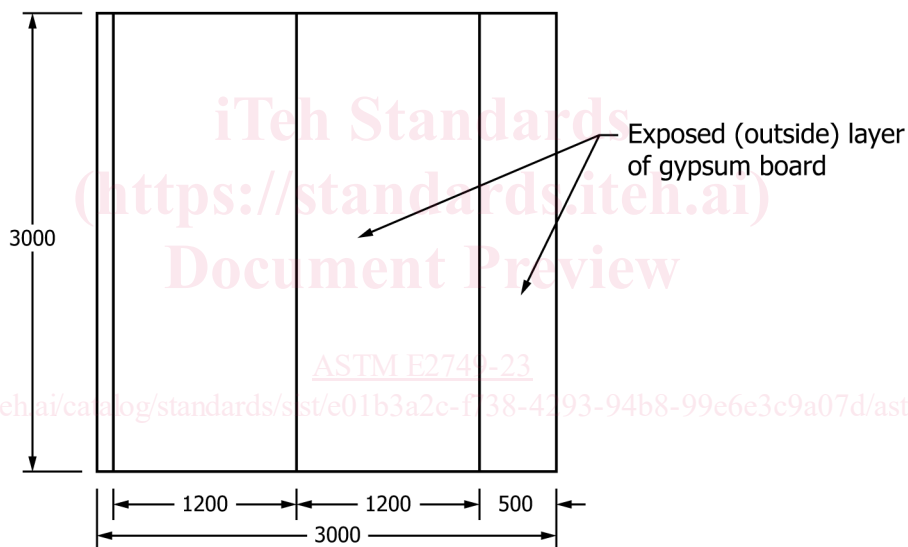

Dimensions in millimetres.

FIG. 6 Vertical Standardized Test Specimen – Location of Outer Layer of Gypsum Board

welded to the plate (Fig. 7) and $25\text{ mm} \pm 1\text{ mm}$ by $6\text{ mm} \pm 1\text{ mm}$ when it is to be screwed to the plate. The screw shall be a maximum 2 mm in diameter.

6.4.1.3 The assembly of the plate and thermocouple shall be fitted with a pad of inorganic insulation material $97\text{ mm} \pm 1\text{ mm}$ by $97\text{ mm} \pm 1\text{ mm}$ by $10\text{ mm} \pm 1\text{ mm}$ thick. The density of the insulation material shall be $280\text{ kg/m}^3 \pm 30\text{ kg/m}^3$.

6.4.1.4 The plate thermometers shall be aged by immersing in a pre-heated oven at $1000\text{ }^\circ\text{C}$ for 1 h before their first use or exposed in a furnace following the time-temperature curve specified in Test Methods E119 for a minimum of 90 min.

6.4.2 The directional flame thermometers(2) shall be constructed as shown in Fig. 8.

6.4.2.1 The plate parts of the directional flame thermometers shall be constructed from 120 mm by $120\text{ mm} \pm 0.1\text{ mm}$ by $3.0\text{ mm} \pm 0.1\text{ mm}$ thick Inconel plate.

6.4.2.2 A $6.7\text{ mm} \pm 0.4\text{ mm}$ diameter (Drill size H) hole shall be drilled near each corner of each plate.

6.4.2.3 The plates shall be oxidized by placing them in a furnace at $1000\text{ }^\circ\text{C} \pm 50\text{ }^\circ\text{C}$ for a minimum of 24 h.

6.4.2.4 By sanding, the oxide shall be removed from an area approximately 13 mm by 31 mm at the geometric center of each plate.

6.4.2.5 In the sanded area, a Type K ungrounded Inconel sheathed thermocouple having a maximum diameter of 1.6 mm shall be fixed to the geometric center of each plate using nickel

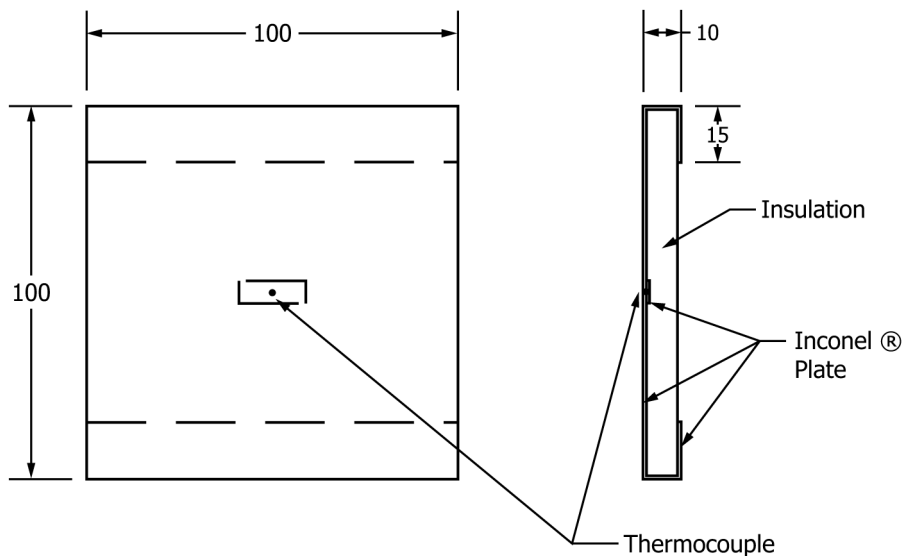

Dimensions in millimetres.

FIG. 7 Plate Thermometer

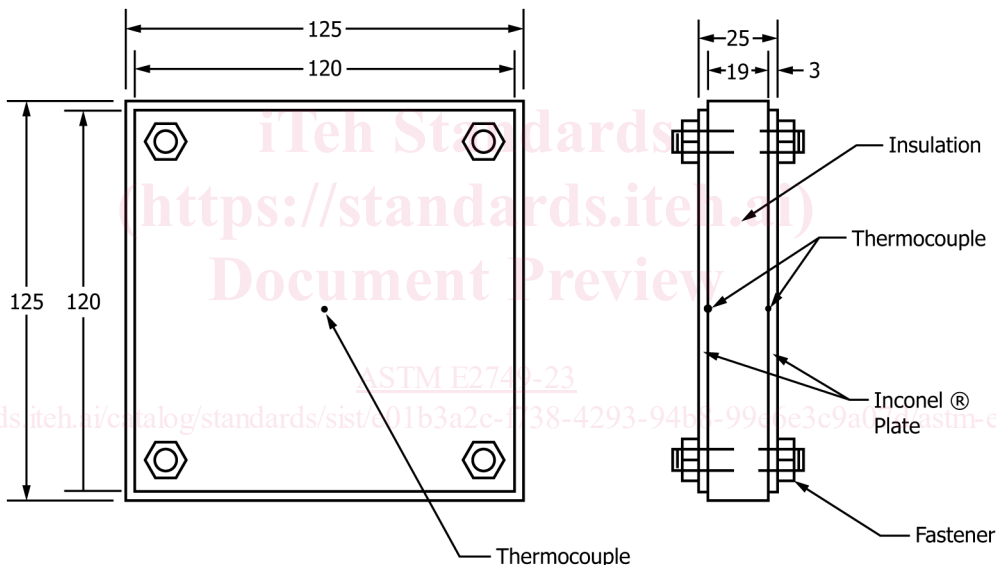

Dimensions in millimetres.

FIG. 8 Directional Flame Thermometer

or nichrome foil tightly fitted over the last 25 mm of the thermocouple and spot welded to the plate.

6.4.2.6 Place a 125 mm by 125 mm by 25 mm thick piece of 128 kg/m³ ceramic fiber insulation between the plates. The plate surface with the thermocouples shall be in contact with the insulation as shown in Fig. 8.

NOTE 5—Cerablanket, manufactured by Thermal Ceramics, has been found to be a suitable insulation.

6.4.2.7 Using stainless steel tubular spacers with 304 stainless steel or Inconel® bolts, compress the insulation to a thickness of 19 mm.

6.4.3 The bi-directional probe(3) shall be constructed as shown in Fig. 9.

6.4.4 The Type K (Chromel–Alumel) Inconel sheathed thermocouple with an ungrounded tip shall have a maximum diameter of 1.5 mm.

6.4.5 The air sampling probes shall be a Tee-shaped probe or a tube probe and shall be manufactured from stainless steel or other suitable material.

6.4.6 The plate thermometers, directional flame thermometer, bi-directional low velocity probes and the probe to measure oxygen content are to be located as shown in Fig. 10.

6.4.6.1 Dimensions A₁ and A₂ are to be determined by the testing laboratory.