



Designation: D2863 – 23

Standard Test Method for Measuring the Minimum Oxygen Concentration to Support Candle-Like Combustion of Plastics (Oxygen Index)¹

This standard is issued under the fixed designation D2863; the number immediately following the designation indicates the year of original adoption or, in the case of revision, the year of last revision. A number in parentheses indicates the year of last reapproval. A superscript epsilon (ϵ) indicates an editorial change since the last revision or reapproval.

This standard has been approved for use by agencies of the U.S. Department of Defense.

1. Scope*

1.1 This fire-test-response standard describes a procedure for measuring the minimum concentration of oxygen, expressed as percent volume, that will just support flaming combustion in a flowing mixture of oxygen and nitrogen.

1.2 This test method provides three testing procedures. Procedure A involves top surface ignition, Procedure B involves propagating ignition, and Procedure C is a short procedure involving the comparison with a specified minimum value of the oxygen index.

1.3 Test specimens used for this test method are prepared into one of six types of specimens (see [Table 1](#)).

1.4 This test method provides for testing materials that are structurally self-supporting in the form of vertical bars or sheet up to 10.5-mm thick. Such materials are solid, laminated or cellular materials characterized by an apparent density greater than 15 kg/m³.

1.5 This test method also provides for testing flexible sheet or film materials, while supported vertically.

1.6 This test method is also suitable, in some cases, for cellular materials having an apparent density of less than 15 kg/m³.

NOTE 1—Although this test method has been found applicable for testing some other materials, the precision of the test method has not been determined for these materials, or for specimen geometries and test conditions outside those recommended herein.

1.7 This test method measures and describes the response of materials, products, or assemblies to heat and flame under controlled conditions, but does not by itself incorporate all factors required for fire hazard or fire risk assessment of the materials, products, or assemblies under actual fire conditions.

1.8 The values stated in SI units are to be regarded as standard. No other units of measurement are included in this standard.

¹ This test method is under the jurisdiction of ASTM Committee D20 on Plastics and is the direct responsibility of Subcommittee D20.30 on Thermal Properties.

Current edition approved Oct. 1, 2023. Published October 2023. Originally approved in 1970. Last previous edition approved in 2019 as D2863 - 19. DOI: 10.1520/D2863-23.

1.9 *This standard does not purport to address all of the safety concerns, if any, associated with its use. It is the responsibility of the user of this standard to establish appropriate safety, health, and environmental practices and determine the applicability of regulatory limitations prior to use. Specific hazards statement are given in Section 10.*

1.10 *Fire testing is inherently hazardous. Adequate safeguards for personnel and property shall be employed in conducting these tests.*

NOTE 2—This test method and ISO 4589-2 are technically equivalent when using the gas measurement and control device described in [6.3.1](#), with direct oxygen concentration measurement.

1.11 *This international standard was developed in accordance with internationally recognized principles on standardization established in the Decision on Principles for the Development of International Standards, Guides and Recommendations issued by the World Trade Organization Technical Barriers to Trade (TBT) Committee.*

2. Referenced Documents

2.1 ASTM Standards:²

- D618 Practice for Conditioning Plastics for Testing
- D883 Terminology Relating to Plastics
- D1071 Test Methods for Volumetric Measurement of Gaseous Fuel Samples
- D1622 Test Method for Apparent Density of Rigid Cellular Plastics
- D4802 Specification for Poly(Methyl Methacrylate) Acrylic Plastic Sheet
- D4968 Practice for Annual Review of Test Methods and Specifications for Plastics
- E176 Terminology of Fire Standards
- E177 Practice for Use of the Terms Precision and Bias in ASTM Test Methods
- E456 Terminology Relating to Quality and Statistics
- E691 Practice for Conducting an Interlaboratory Study to Determine the Precision of a Test Method

² For referenced ASTM standards, visit the ASTM website, www.astm.org, or contact ASTM Customer Service at service@astm.org. For *Annual Book of ASTM Standards* volume information, refer to the standard's Document Summary page on the ASTM website.

*A Summary of Changes section appears at the end of this standard

TABLE 1 Test Specimen Dimensions

Test Specimen Type ^A	Dimensions			Material Form
	Length, mm	Width, mm	Thickness, mm	
I	80 to 150	10 ± 0.5	4 ± 0.25	for molding materials
II	80 to 150	10 ± 0.5	10 ± 0.5	for cellular materials
III ^B	80 to 150	10 ± 0.5	≤ 10.5	for sheet materials
IV	70 to 150	6.5 ± 0.5	3 ± 0.25	alternative size for self-supporting molding or sheet materials
V ^B	140 ± 5	52 ± 0.5	≤ 10.5	for flexible film or sheet
VI ^{B, C}	140 to 200	20	0.02 to 0.10	for thin film; limited to film that can be rolled by the wire specified in 6.7

^A Test specimens of Types I, II, III, and IV are suitable for materials that are self-supporting at these dimensions. Test specimens of Form V and VI are suitable for materials that require support during testing. Test specimens of Form VI are suitable for film materials that can be rolled into a self-supporting specimen by the procedure in 7.4.

^B Compare results obtained using Type III, V, and VI test specimens only to those obtained using specimens of the same form and thickness. It is assumed that the amount of variation in thickness for such materials will be controlled by other standards.

^C The test specimen of Type VI is suitable for thin film that is self-supporting when it is rolled (see 7.4). Dimensions in the table are of the specimen size from which the rolled form is made. If the film is very thin, it is possible that proper results will only be obtained if two or more layers are combined in the preparation of the roll to obtain proper results.

E2935 Practice for Evaluating Equivalence of Two Testing Processes

2.2 ISO Standards:³

ISO 4589-2 Plastics—Determination of Flammability by Oxygen Index—Part 2, Ambient Temperatures

ISO 7823-1 Poly(Methylmethacrylate) Sheets—Types, Dimensions and Characteristics—Part 1—Cast Sheets

ISO 13943 Fire Safety—Vocabulary

3. Terminology

3.1 Definitions—For definitions of terms relating to plastics, the definitions in this test method are in accordance with Terminology D883. For terms relating to fire, the definitions in this test method are in accordance with Terminology E176 and ISO 13943. In case of conflict, the definitions given in Terminology E176 shall prevail. For terms relating to precision and bias and associated issues, the terms used in this test method are in accordance with the definitions in Terminology E456.

3.2 Definitions of Terms Specific to This Standard:

3.2.1 ignition—the initiation of combustion.

3.2.2 oxygen index (OI)—the minimum concentration of oxygen, expressed as volume percent, in a mixture of oxygen and nitrogen that will just support flaming combustion of a material initially at 23 ± 2°C under the conditions of this test method.

4. Summary of Test Method

4.1 A small test specimen is supported vertically in a mixture of oxygen and nitrogen flowing upwards through a

transparent chimney. The upper end of the specimen is ignited and the subsequent burning behavior of the specimen is observed to compare the period for which burning continues, or the length of specimen burnt, with specified limits for each burning. By testing a series of specimens in different oxygen concentrations, the minimum oxygen concentration is determined.

4.2 Three procedures are included in this test method. In Procedure A, a complete assessment of the oxygen index is conducted using top surface ignition. In Procedure B, a complete assessment of the oxygen index is conducted using propagating ignition. Procedure C provides a comparison with a specified minimum value of oxygen index and can be conducted using top surface ignition or propagating ignition.

5. Significance and Use

5.1 This test method provides for the measuring of the minimum concentration of oxygen in a flowing mixture of oxygen and nitrogen that will just support flaming combustion of plastics. Correlation with burning characteristics under actual use conditions is not implied.

5.2 In this test method, the specimens are subjected to one or more specific sets of laboratory test conditions. If different test conditions are substituted or the end-use conditions are changed, it is not always possible by or from this test to predict changes in the fire-test-response characteristics measured. Therefore, the results are valid only for the fire-test-exposure conditions described in this test method.

6. Apparatus

6.1 Test Chimney. The test chimney consists of a heat-resistant glass tube of 75 to 100-mm inside diameter and 450 to 500-mm height. The opening at the top of the chimney shall be restricted to provide an outlet of 40 ± 2-mm diameter, either by providing an overhead cap or by designing the glass chimney appropriately. The bottom of the chimney, or the base to which the tube is attached, shall contain noncombustible material to evenly mix and distribute the gas mixture entering at this base. Glass beads 3 to 5 mm in diameter in a bed 80 to 100-mm deep have been found suitable. The chimney shall be mounted securely on the base to prevent air leaks. One example of a design is shown in Fig. 1.

NOTE 3—It is helpful to place a wire screen above the noncombustible material to catch falling fragments and to aid in keeping the base of the column clean.

6.2 Specimen Holders

6.2.1 Specimen Holder for Self-Supporting Specimens—Any small holding device that will support the specimen at its base and hold it vertically in the center of the chimney is an acceptable specimen holder. A typical arrangement (see Fig. 1) consists of a laboratory thermometer clamp inserted into the end of a glass tube held in place by glass beads or otherwise firmly supported.

6.2.2 Specimen Holder for Specimens of Flexible Sheet or Film Materials that Require Support—A specimen holder for flexible film or sheet materials that require support shall be able to support the specimen by both vertical edges in a frame equivalent to that illustrated by Fig. 2, with reference marks at

³ Available from International Organization for Standardization (ISO), ISO Central Secretariat, BIBC II, Chemin de Blandonnet 8, CP 401, 1214 Vernier, Geneva, Switzerland, http://www.iso.org.

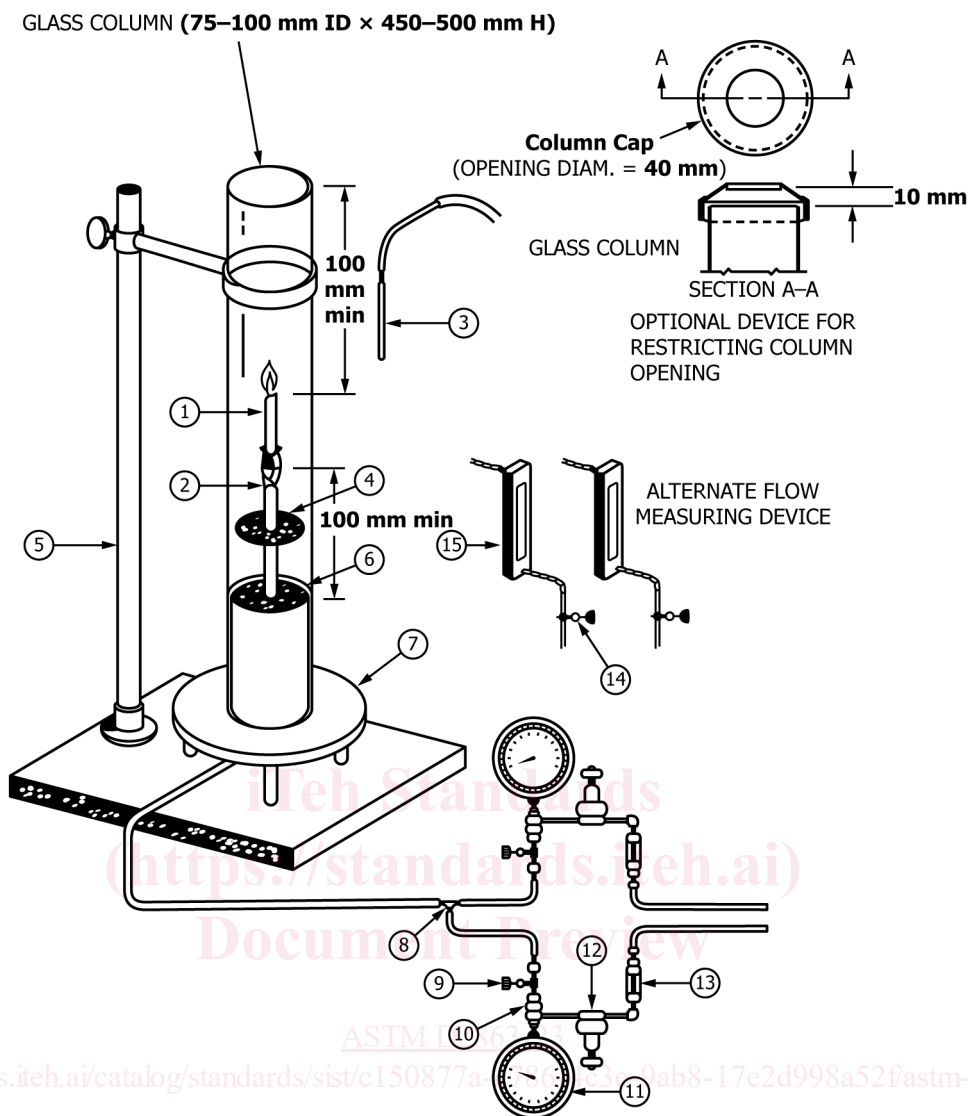

- 1. Burning Specimen
- 2. Clamp with Rod Support
- 3. Igniter
- 4. Wire Screen
- 5. Ring Stand

- 6. Glass Beads in a Bed
- 7. Brass Base
- 8. Tee
- 9. Cut-Off Valve
- 10. Orifice in Holder

- 11. Pressure Gauge
- 12. Precision Pressure Regulator
- 13. Filter
- 14. Needle Valve
- 15. Rotameter

FIG. 1 Typical Equipment Layout

20 and 100 mm below the top of the frame. The profile of the holder and its support shall be smooth to minimize induction of turbulence in the rising flow of gas.

6.2.3 *Thin Film Rolling Tool*—In order to prepare self-supporting specimens from thin films (see 7.4), use a 2 ± 0.1 -mm stainless steel rod with a 0.3 ± 0.05 -mm slit at one end, equivalent to that illustrated in Fig. 3. The actual specimen holder shall be the one in 6.2.1.

6.3 *Gas Measurement and Control Devices.* Gas measurement and control devices shall be suitable for measuring the concentration of oxygen in the gas mixture entering the chimney with an accuracy of ± 0.5 %, by volume, of the gas mixture and for adjusting the concentration of oxygen in the

mixture with a precision of ± 0.1 %, by volume, of the gas mixture, when the gas velocity through the chimney is 40 ± 2 mm/s at $23 \pm 2^\circ\text{C}$.

6.3.1 The system for direct gas measurement and control involves needle valves on individual and mixed gas supply lines, a paramagnetic oxygen analyzer that continuously samples the mixed gas, and a flow meter to indicate when the gas flow through the chimney is within the required limits.

6.3.2 An alternate system for gas measurement is described in Annex A4. The system used for indirect gas measurement (Annex A4) requires calibration after assembly to ensure that the compounded errors of the component parts do not exceed the requirements of 6.3.

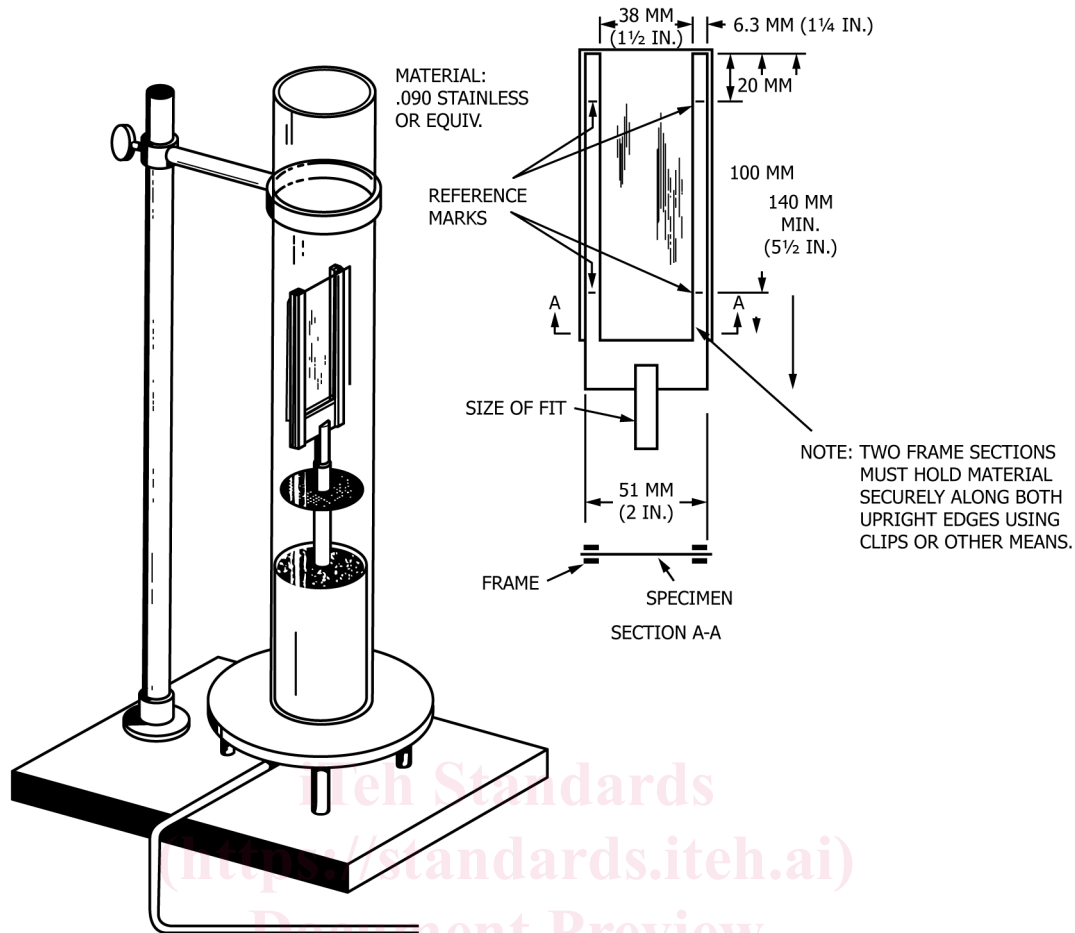

FIG. 2 Frame Design

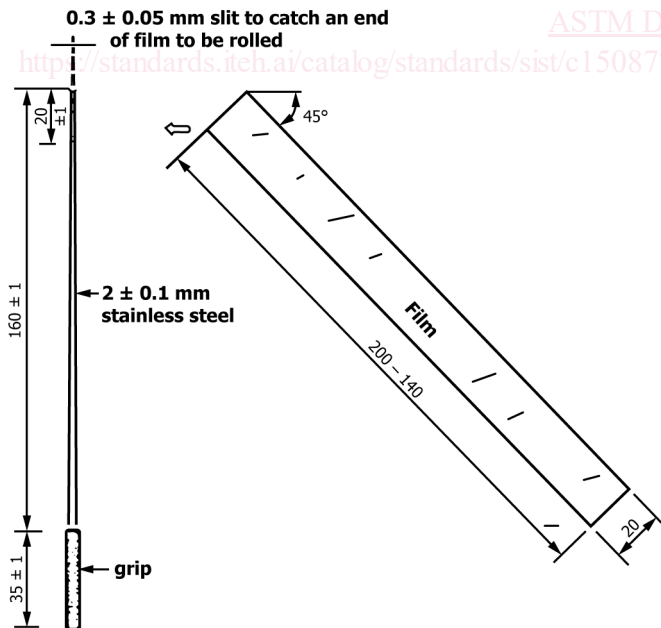

FIG. 3 Rod with a Slit

6.3.3 Means shall be provided for checking or ensuring that the temperature of the gas mixture entering the chimney is 23

ASTM D2863 ± 2°C. If this involves an internal probe, its position and profile shall be designed to minimize induction of turbulence within the chimney.

6.4 *Flame Igniter*. The flame igniter shall comprise a tube, with an inside diameter of 2 ± 1 mm, that can be inserted into the chimney to apply the test flame.

6.4.1 The fuel supply shall be adjusted so that the flame height is 16 ± 4 mm (measured from the bottom of the flame to the top of the flame) when the flame igniter tube is vertical within the chimney and the flame is burning within the chimney atmosphere (see Fig. 4).

6.4.2 The flame fuel shall be one of the following: methane, or natural gas of at least 97 % purity, or propane of at least 98 % purity. The flame fuel shall have no premixed air.

6.5 *Timing Device*. A timing device shall be provided, which is capable of measuring periods up to 5 min with an accuracy of ± 0.5 s.

6.6 *Fume Extraction System*. A fume extraction system shall be provided with sufficient ventilation or exhaust to remove fumes or soot expelled from the chimney without disrupting the gas-flow rate or temperatures in the chimney.

NOTE 4—If soot-generating materials are being tested, it is likely that the glass chimney, gas inlets, and inlet screen will require cleaning between tests to maintain good visibility and to function properly.

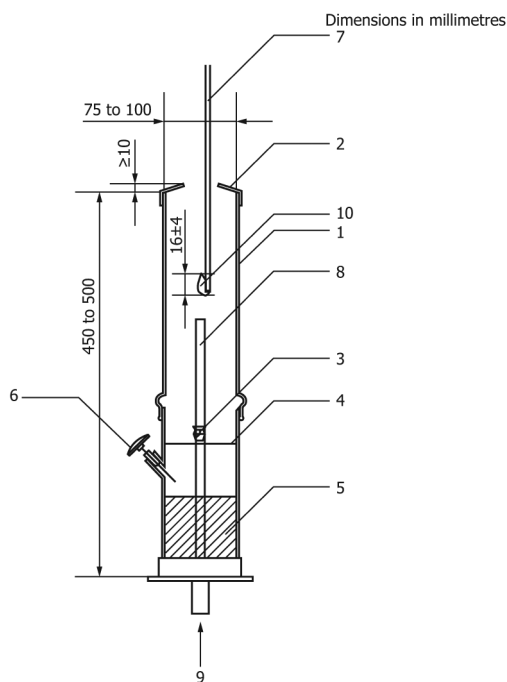

- Key**
- | | |
|---------------------------------|---|
| 1 chimney | 6 optional temperature measurement device |
| 2 chimney cap | 7 tube |
| 3 specimen holder | 8 test specimen |
| 4 wire-mesh debris screen | 9 oxygen/nitrogen mixture |
| 5 diffuser and a mixing chamber | 10 flame igniter |

FIG. 4 Oxygen Index Apparatus Schematic Showing Igniter Flame Detail

6.7 *Gas Supplies.* The gas supplied to the test apparatus shall consist of pressurized sources of oxygen or nitrogen, or both, not less than 98 % pure or clean dry air, or both, (containing 20.9 % oxygen), as appropriate.

6.7.1 The gas mixture entering the chimney shall have a moisture content of <0.1 %, unless the results have been shown to be insensitive to higher moisture levels in the gas mixture. The gas supply system shall incorporate a drying device, or provision for monitoring or sampling the gas supply for moisture content, unless the moisture content of the gas supplies is known to be acceptable.

NOTE 5—It must be noted that bottled oxygen or nitrogen will not always contain <0.1 % of water; moisture contents of 0.003 to 0.01 % are typical for commercial supplies as filled bottles >98 % pure, but as such bottled gases are depressured to below about 1 MPa, the moisture content of the gas drawn off has been found to rise above 0.1 %.

7. Test Specimens

7.1 General:

7.1.1 The specimens shall be die-punched, cut by hand using a razor blade or other sharp tool, or cut by an automatic machine. Alternatively, specimens shall be prepared directly by injection molding.

7.1.2 Ensure that the surfaces of the specimens are clean and free from flaws that could affect burning behavior, for example, peripheral molding flash or burrs from machining. The edges of the specimens shall be smooth and free from fuzz or burrs of material left from machining or molding.

7.1.3 Record the position and orientation of the test specimens with respect to any asymmetry in the sample material (see Note 6).

NOTE 6—Oxygen index results are likely to be significantly affected by differences in burning behavior, due to material inhomogeneity (for example, different levels of shrinkage when heated for specimens cut in different directions from asymmetrically-oriented thermoplastics film).

7.1.4 The test specimens shall conform to the dimensions and geometry listed in Table 1. If non-standard size specimens are used, a difference in oxygen index is likely to result.

7.1.5 It is likely that, for materials where the oxygen index is known to within ± 2 % by volume, 15 test specimens will be sufficient. However, for materials of unknown oxygen index, or which exhibit erratic burning characteristics, between 15 and 30 test specimens are likely to be required.

7.2 Self-Supporting Specimens (Specimen Types I, II, III, and IV)

7.2.1 The specimens shall be prepared in accordance with 7.1.

7.3 Specimens of Flexible Sheet or Film Materials that Require Support (Specimen Type IV)

7.3.1 The specimens shall be prepared in accordance with 7.1 and they shall be supported by both vertical edges in a frame equivalent to that illustrated by Fig. 2 (see 6.2.2).

7.4 Self-Supporting Specimens Rolled from Thin Films (Specimen Type VI)

7.4.1 For preparation of Type VI specimens, use the rolling tool described in 6.2.3.

7.4.2 Specimen films shall be prepared in accordance with 7.1.

7.4.3 Insert one corner of the film into the slit of the thin film rolling tool and then wind the film around the rod in a spiral of 45°, as shown in Fig. 3. Ensure that the 45° angle is maintained during the winding process so that the film reaches exactly to the end of the tool, to produce a test piece of the correct length. After the winding is finished, tape the last end of the roll while the material is still on the stainless steel rod to prevent loosening. Then pull the rod out of the rolled film.

7.4.4 Cut off the rolled film at a distance of 20 mm from the top end. See Fig. 5.

7.5 Specimen Marking

7.5.1 For monitoring the distance over which burning occurs, mark the specimen with transverse lines at one or more levels which are dependent upon the specimen form and the ignition procedure to be used. Structurally self-supporting specimens shall be marked on at least two adjacent faces. If wet inks are used, ensure that the marks are dry before the specimen is ignited.

7.5.2 If test specimens of Type I, II, III, IV, or VI are to be tested in accordance with Procedure A, they shall be marked 50 mm from the end to be ignited. If specimens of Type I, II, III, IV, and VI are to be tested in accordance with Procedure B, they shall be marked at 10 mm and at 60 mm from the end to be ignited.

7.5.3 The reference marks for testing specimens of Type V are carried by the supporting frame (see Fig. 2), but thermally stable materials shall additionally be marked at 20 mm and at 100 mm from the end to be ignited, for convenience.

7.6 For cellular materials, the density shall be determined in accordance with Test Method D1622.

NOTE 7—It is possible that the oxygen index samples of cellular materials that contain volatile flammable blowing agents that diffuse from the sample will change with time.

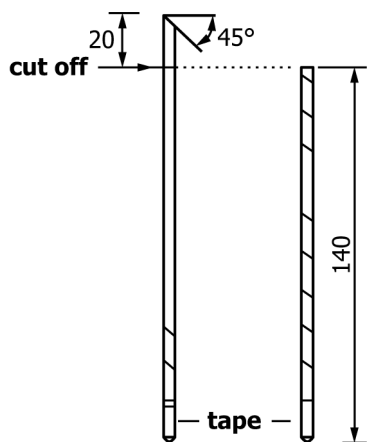

FIG. 5 Rolled Film

8. Conditioning

8.1 Unless otherwise specified, each test specimen shall be conditioned for at least 40 h at $23 \pm 2^\circ\text{C}$ and $50 \pm 5\%$ relative humidity (RH) immediately prior to use in accordance with Practice D618.

8.2 Maintain the ambient conditions for the test apparatus at $23 \pm 5^\circ\text{C}$. Keep the test specimens in an enclosure at $23 \pm 2^\circ\text{C}$ and $50 \pm 5\%$ RH and take the test specimens out of the enclosure just before testing (so that testing is conducted within 30 minutes of the test specimen removal from the conditioning environment).

9. Calibration of Apparatus

9.1 Calibration for systems with direct oxygen gas concentration measurement. Calibrate the system for direct oxygen gas concentration measurement with a paramagnetic oxygen analyzer, used for the measurements in 6.3.1, by the following: (a) turning the nitrogen flow on and closing the oxygen flow and confirming that the oxygen concentration on the display reads 0.0 %, and (b) turning the oxygen flow on and closing the nitrogen flow and confirming that the oxygen concentration on the display reads the same value as the concentration of oxygen in the supply gas (see 6.7).

9.2 Calibration for systems using indirect gas measurement in accordance with Annex A4. Calibrate the flow-measuring system used for the indirect measurements of oxygen concentration and flow rate with the instrumentation in 6.3.2 using a water-sealed rotating drum meter (wet test meter) in accordance with Test Method D1071 or by equivalent calibration devices. The maximum interval between recalibration shall be six months.

9.3 A cast PMMA specimen shall be used as a verification material at least once a month. See Annex A1 for calibration method.

10. Hazards

10.1 The exhaust system must be so designed and operated that the laboratory environment is protected from smoke and gases or vapors. The operator shall be instructed on ways to minimize exposure to combustion products by following sound safety and industrial hygiene practices. For example, ensure that the exhaust system is working properly and wear appropriate clothing including gloves, safety glasses, breathing apparatus (when hazardous fumes are expected).

10.2 During this test, high temperatures are generated that are capable of igniting some clothing following even brief exposures. Precautions shall be taken to avoid ignitions of this type.

11. Symbols and Criteria for This Test Method

11.1 Test Method Criteria:

11.1.1 The criteria for oxygen index measurements are described in Table 2.

11.1.2 The extent of burning in this test method is considered to have been exceeded when any part of the visibly