



Standard Consumer Safety Specification for Toy Safety¹

This standard is issued under the fixed designation F963; the number immediately following the designation indicates the year of original adoption or, in the case of revision, the year of last revision. A number in parentheses indicates the year of last reapproval. A superscript epsilon (ϵ) indicates an editorial change since the last revision or reapproval.

INTRODUCTION

The purpose of this consumer safety specification is to establish nationally recognized safety requirements for toys. Although this specification will not eliminate the need for the exercise of parental responsibility in selecting toys appropriate to the age of a child, or parental supervision in situations in which children of various ages may have access to the same toys, its application will minimize accidents in the normal, intended use and reasonably foreseeable abuse of the toys covered by this specification. This specification was developed originally as a Voluntary Product Standard under the auspices of the National Bureau of Standards, Department of Commerce, and published in 1976 (PS 72–76). The present revision is intended to update the safety requirements to include the following by reference: published federal mandatory requirements, relevant voluntary standards, certain new requirements for addressing potential hazards, and several technical revisions based on producer experience with the original standard.

1. Scope

1.1 This specification² relates to possible hazards that may not be recognized readily by the public and that may be encountered in the normal use for which a toy is intended or after reasonably foreseeable abuse. It does not purport to cover every conceivable hazard of a particular toy. This specification does not cover product performance or quality, except as related to safety. Except for the labeling requirements pointing out the functional hazards and age range for which the toy is intended, this specification has no requirements for those aspects of a toy that present an inherent and recognized hazard as part of the function of the toy. Such an example is a sharp point necessary for the function of a needle. The needle is an inherent hazard that is well understood by the purchaser of a toy sewing kit, and this hazard is communicated to the user as part of the normal educational process.

1.2 On the other hand, while a riding toy has inherent hazards associated with its use (for example, falling off onto the sidewalk), the possible hazards associated with its con-

struction (sharp edges, exposed mechanisms, etc.) will be minimized by the application of this specification.

1.3 This specification covers requirements and contains test methods for toys intended for use by children under 14 years of age. Different age limits for various requirements will be found in this specification. These limits reflect the nature of the hazards and expected mental or physical ability, or both, of a child to cope with the hazards.

1.4 Articles not covered by this specification are as follows:

- Bicycles
- Tricycles
- Non-Powered Scooters
(see Consumer Safety Specification [F2264](#))
- Recreational Powered Scooters and Pocket Bikes
(see Consumer Safety Specification [F2641](#))
- Sling shots and sharp-pointed darts
- Playground equipment
- Non-powder guns
- Kites
- Hobby and craft items in which the finished item is not primarily of play value
- Model kits in which the finished item is not primarily of play value
- Crayons, paints, chalks, and other similar art materials in which the material itself or the finished item is not primarily of play value, except that all art materials, whether or not a component of a toy, shall comply with [LHAMA](#), in accordance with [4.29.1 – 4.29.3](#).
- Sporting goods, camping goods, athletic equipment,

¹ This consumer safety specification is under the jurisdiction of ASTM Committee [F15](#) on Consumer Products and is the direct responsibility of Subcommittee [F15.22](#) on Toy Safety.

Current edition approved Aug. 1, 2023. Published October 2023. Originally approved in 1986. Last previous edition approved in 2017 as F963 – 17. DOI: 10.1520/F0963-23.

² The Toy Association sometimes provides its interpretations of this specification through its counsel as a service to its members and others. The Toy Association's interpretations are not reviewed or approved by ASTM and should be viewed as The Toy Association's alone.

musical instruments, juvenile products, and furniture; however, toys that are their counterparts are covered. (It is recognized that there is often a fine line between, for example, a musical instrument or a sporting item and its toy counterpart. The intention of the producer or distributor, as well as normal use and reasonably foreseeable abuse, determines whether the item is a toy counterpart.)

Powered models of aircraft, rockets, boats, and land vehicles; however, toys that are their counterparts are covered.

Constant air inflatables

1.5 General guidelines for age labeling toys and toy packaging are contained in **Annex A1**.

1.6 Information regarding packaging and shipping is contained in **Annex A2**.

1.7 This consumer safety specification includes the following sections:

| Title | Section |
|---|---------|
| Scope | 1 |
| Referenced Documents | 2 |
| Terminology | 3 |
| Safety Requirements | 4 |
| Material Quality | 4.1 |
| Flammability | 4.2 |
| Toxicology | 4.3 |
| Electrical/Thermal Energy | 4.4 |
| Sound-producing Toys | 4.5 |
| Small Objects | 4.6 |
| Accessible Edges | 4.7 |
| Projections | 4.8 |
| Accessible Points | 4.9 |
| Wires or Rods | 4.10 |
| Nails and Fasteners | 4.11 |
| Plastic Film | 4.12 |
| Folding Mechanisms and Hinges | 4.13 |
| Cords, Straps, and Elastics | 4.14 |
| Stability and Over-load Requirements | 4.15 |
| Confined Spaces | 4.16 |
| Wheels, Tires, and Axles | 4.17 |
| Holes, Clearance, and Accessibility of Mechanisms | 4.18 |
| Simulated Protective Devices | 4.19 |
| Pacifiers | 4.20 |
| Projectile Toys | 4.21 |
| Teethers and Teething Toys | 4.22 |
| Rattles | 4.23 |
| Squeeze Toys | 4.24 |
| Battery-operated Toys | 4.25 |
| Toys Intended to be Attached to a Crib or Playpen | 4.26 |
| Stuffed and Beanbag-type Toys | 4.27 |
| Stroller and Carriage Toys | 4.28 |
| Art Materials | 4.29 |
| Toy Gun Marking | 4.30 |
| Balloons | 4.31 |
| Certain Toys with Nearly Spherical Ends | 4.32 |
| Marbles | 4.33 |
| Balls | 4.34 |
| Pompoms | 4.35 |
| Hemispheric-shaped Objects | 4.36 |
| Yo Yo Elastic Tether Toys | 4.37 |
| Magnets | 4.38 |
| Jaw Entrapment in Handles and Steering Wheels | 4.39 |
| Expanding Materials | 4.40 |
| Toy Chests | 4.41 |
| Labeling Requirements | 5 |

| | |
|--|-----------|
| Instructional Literature | 6 |
| Producer's Markings | 7 |
| Test Methods | 8 |
| General | 8.1 |
| Testing for Hazardous Substance Content | 8.2 |
| Test Methods for Determination of Heavy Element Content in Toys, Toy Components, and Materials | 8.3 |
| Tests for Cleanliness and Preservative Effectiveness | 8.4 |
| Normal Use Testing | 8.5 |
| Abuse Testing | 8.6 |
| Impact Tests | 8.7 |
| Torque Tests for Removal of Components | 8.8 |
| Tension Test for Removal of Components | 8.9 |
| Compression Test | 8.10 |
| Tests for Tire Removal and Snap-in Wheel and Axle Assembly Removal | 8.11 |
| Flexure Test | 8.12 |
| Test for Mouth-actuated Toys and Mouth-actuated Projectile Toys | 8.13 |
| Projectiles | 8.14 |
| Test for Stability of Ride-on Toys or Toy Seats | 8.15 |
| Pompoms | 8.16 |
| Stalled Motor Test for Battery-operated Toys | 8.17 |
| Tests for Battery-Powered Ride-on Toys | 8.18 |
| Test for Toys that Contain Secondary Cells or Batteries | 8.19 |
| Tests for Toys which Produce Sound | 8.20 |
| Dynamic Strength Test for Wheeled Ride-on Toys | 8.21 |
| Plastic Film Thickness | 8.22 |
| Test for Loops and Cords | 8.23 |
| Yo Yo Elastic Tether Toy Test Methods | 8.24 |
| Magnet Test Methods | 8.25 |
| Test Methods for Locking Mechanisms or Other Means | 8.26 |
| Tests for Toy Chest Lids and Closures | 8.27 |
| Test for Overload of Ride-on Toys and Toy Seats | 8.28 |
| Stuffing Materials Evaluation | 8.29 |
| Expanding Materials – Test Method | 8.30 |
| Identification | 9 |
| Age Grading Guidelines | Annex A1 |
| Packaging and Shipping | Annex A2 |
| Design Guidelines for Toys Attached to Cribs or Playpens | Annex A3 |
| Design Guidelines for Bath Toy Projections | Annex A4 |
| Flammability Testing Procedure for Solids and Soft Toys | Annex A5 |
| Flammability Testing Procedure for Fabrics | Annex A6 |
| Compositing Procedure for Total Heavy Metal Analysis | Annex A7 |
| Design Guidelines for Battery Operated Toys | Annex A8 |
| Rationale for 2007 Revisions | Annex A9 |
| Rationale for 2008 Revisions | Annex A10 |
| Rationale for 2011 Revisions | Annex A11 |
| Rationale for 2016 Revisions | Annex A12 |
| Rationale for 2017 Revisions | Annex A13 |
| Rationale for 2023 Revisions | Annex A14 |

1.8 The values stated first are to be regarded as the standard. The values given in parentheses are for information only.

1.9 The following precautionary statement pertains only to the test methods portion, Section 8, of this specification: *This standard does not purport to address all of the safety concerns, if any, associated with its use. It is the responsibility of the user of this standard to establish appropriate safety, health, and environmental practices and determine the applicability of regulatory limitations prior to use.*

1.10 *This international standard was developed in accordance with internationally recognized principles on standardization established in the Decision on Principles for the Development of International Standards, Guides and Recommendations issued by the World Trade Organization Technical Barriers to Trade (TBT) Committee.*

2. Referenced Documents

2.1 *ASTM Standards*:³

- D374/D374M Test Methods for Thickness of Solid Electrical Insulation
- D642 Test Method for Determining Compressive Resistance of Shipping Containers, Components, and Unit Loads
- D880 Test Method for Impact Testing for Shipping Containers and Systems
- D999 Test Methods for Vibration Testing of Shipping Containers
- D1193 Specification for Reagent Water
- D2240 Test Method for Rubber Property—Durometer Hardness
- D4236 Practice for Labeling Art Materials for Chronic Health Hazards
- D5276 Test Method for Drop Test of Loaded Containers by Free Fall
- F404 Consumer Safety Specification for High Chairs
- F406 Consumer Safety Specification for Non-Full-Size Baby Cribs/Play Yards
- F1066 Specification for Vinyl Composition Floor Tile
- F1313 Specification for Volatile *N*-Nitrosamine Levels in Rubber Nipples on Pacifiers (Withdrawn 2020)⁴
- F1148 Consumer Safety Performance Specification for Home Playground Equipment
- F2264 Consumer Safety Specification for Non-Powered Scooters
- F2641 Consumer Safety Specification for Recreational Powered Scooters and Pocket Bikes
- F2853 Test Method for Determination of Lead in Paint Layers and Similar Coatings or in Substrates and Homogenous Materials by Energy Dispersive X-Ray Fluorescence Spectrometry Using Multiple Monochromatic Excitation Beams
- F2923 Specification for Consumer Product Safety for Children's Jewelry

2.2 *ANSI Standards*:⁵

- ANSI C18.1 M, Part 1 American National Standard for Portable Primary Cells and Batteries with Aqueous Electrolyte – General and Specifications
- ANSI C18.1 M, Part 2 American National Standard for Portable Primary Cells and Batteries with Aqueous Electrolyte – Safety Standard
- ANSI C18.2 M, Part 1 American National Standard for Portable Rechargeable Cells and Batteries – General and Specifications
- ANSI C18.2 M, Part 2 American National Standard for Portable Rechargeable Cells and Batteries – Safety Standard

- ANSI C18.3 M, Part 1 American National Standard for Portable Lithium Primary Cells and Batteries – General and Specifications
- ANSI C18.3 M, Part 2 American National Standard for Portable Lithium Primary Cells and Batteries – Safety Standard
- ANSI/UL 1012 Power Units Other Than Class 2
- ANSI/UL 60950–1 Information Technology Equipment – Safety – Part 1: General Requirements
- ANSI/UL 2595 General Requirements for Battery-Powered Appliances
- S1.4 Specification for Sound Level Meters
- Z315.1 Safety Requirements for Tricycles
- ### 2.3 *European Union Standards*:⁶
- EN 71-1 Safety of toys – Part 1: Mechanical and physical properties
- EN 71-3 Safety of toys – Part 3: Migration of certain elements
- ### 2.4 *Federal Standards*:⁷
- 15 CFR 272 Marking of Toy, Look-Alike and Imitation Firearms
- 16 CFR 1199.1 Children's toys and child care articles: Phthalate-containing inaccessible component parts
- 16 CFR 1251 Toys: Determinations Regarding Heavy Elements Limits for Certain Materials
- 16 CFR 1252 Children's Products, Children's Toys, and Child Care Articles: Determinations Regarding Lead, ASTM F963 Elements, and Phthalates for Engineered Wood Products
- 16 CFR 1253 Children's Toys and Child Care Articles: Determinations Regarding the ASTM F963 Elements and Phthalates for Unfinished Manufactured Fibers
- 16 CFR 1303 Ban of Lead-Containing Paint and Certain Consumer Products Bearing Lead Containing Paint
- 16 CFR 1307 Prohibition of Children's Toys and Child Care Articles Containing Specified Phthalates
- 16 CFR 1308 Prohibition of Children's Toys and Child Care Articles Containing Specified Phthalates: Determinations Regarding Certain Plastics
- 16 CFR 1500 Hazardous Substances Act Regulations, including the following sections:
- 16 CFR 1500.3 (c) (6) (vi) Definition of "flammable solid"
- 16 CFR 1500.14 Products requiring special labeling under section 3(b) of the act
- 16 CFR 1500.18 Banned toys and other banned articles intended for use by children
- 16 CFR 1500.19 Misbranded toys and other articles intended for use by children
- 16 CFR 1500.44 Method for determining extremely flammable and flammable solids
- 16 CFR 1500.48 Technical requirements for determining a sharp point in toys and other articles intended for use by children under 8 years of age

³ For referenced ASTM standards, visit the ASTM website, www.astm.org, or contact ASTM Customer Service at service@astm.org. For *Annual Book of ASTM Standards* volume information, refer to the standard's Document Summary page on the ASTM website.

⁴ The last approved version of this historical standard is referenced on www.astm.org.

⁵ Electronic copy available from American National Standards Institute website: www.ansi.org; hard copies from Global Engineering Documents, 15 Inverness Way East, Englewood, CO 80112.

⁶ Available from European Committee for Standardization (CEN), Avenue Marnix 17, B-1000, Brussels, Belgium, <http://www.cen.eu>.

⁷ Available from U.S. Consumer Product Safety Commission website: www.cpsc.gov or U.S. Government Printing Office, Superintendent of Documents; P.O. Box 371954, Pittsburgh, PA 15250-7954; website: www.gpo.gov

16 CFR 1500.49 Technical requirements for determining a sharp metal or glass edge in toys and other articles intended for use by children under 8 years of age

16 CFR 1500.50-53 Test method for simulating use and abuse of toys and other articles intended for use by children

16 CFR 1500.83 Exemptions for small packages, minor hazards, and special circumstances

16 CFR 1500.85 Exemptions from classification as banned hazardous substances

16 CFR 1500.86 Exemptions from classification as a banned toy or other banned article for use by children

16 CFR 1500.87 Children's products containing lead: inaccessible component parts

16 CFR 1500.88 Exemptions from lead limits under section 101 of the Consumer Product Safety Improvement Act for certain electronic devices

16 CFR 1500.91 Determinations regarding lead content for certain materials or products under section 101 of the Consumer Product Safety Improvement Act

16 CFR 1501 Method for Identifying Toys and Other Articles Intended for Use by Children Under 3 Years of Age which Present Choking, Aspiration, or Ingestion Hazards Because of Small Parts

16 CFR 1505 Requirements for Electrically Operated Toys or Other Electrically Operated Articles Intended for Use by Children

16 CFR 1510 Requirements for Rattles

16 CFR 1511 Requirements for Pacifiers

16 CFR 1610 Standard for Flammability of Clothing Textiles

21 CFR 110 Current Good Manufacturing Practice in Manufacturing, Processing, Packaging, or Holding Human Food

21 CFR 170-189 Food for Human Consumption

21 CFR 700-740 Requirements for Specific Cosmetic Products

21 CFR 73, 74, 81, 82 Color Additives

29 CFR 1910 Occupational Safety and Health Standards

40 CFR 141.63 Maximum Contaminant Levels (MCLs) for Microbiological Contaminants

49 CFR 173.100, 109 Definition of Class C Explosives

CPSC-CH-C1001-09.4 Standard Operating Procedure for Determination of Phthalates⁸

CPSC-CH-E1001-08.3 Standard Operating Procedure for Determining Total Lead (Pb) in Metal Children's Products (including Children's Metal Jewelry)⁸

CPSC-CH-E1002-08.3 Standard Operating Procedure for Determining Total Lead (Pb) in Non-Metal Children's Products⁸

CPSC-CH-E1003-09.1 Standard Operating Procedure for Determining Lead (Pb) in Paint and Other Similar Surface Coatings⁸

CPSC-CH-E1004-11 Standard Operating Procedure for Determining Cadmium (Cd) Extractability from Children's Metal Jewelry⁸

MIL-D-17951 Military Specification: Deck Covering, Lightweight, Nonslip, Abrasive Particle Coated Fabric, Film, or Composite and Sealing Compound

Voluntary Product Standard PS 72-76 Toy Safety⁹

2.5 ISO and IEC Standards:¹⁰

ISO 3696 Water for analytical laboratory use – Specification and test methods

ISO 3746:1995 Acoustics – Determination of Sound Power Levels of Noise Sources Using Sound Pressure – Survey Method Using an Enveloping Measurement Surface Over a Reflecting Plane

ISO 7779 Acoustics – Measurement of Airborne Noise Emitted by Computer and Business Equipment

ISO 8124-1 Safety of toys – Part 1: Safety aspects related to mechanical and physical properties

ISO 8124-3 Safety of toys – Part 3: Migration of certain elements

ISO 11201 Acoustics – Noise Emitted by Machinery and Equipment – Determination of Emission Sound Pressure Levels at a Work Station and at Other Specified Positions in an Essentially Free Field Over a Reflecting Plane with Negligible Environmental Corrections

ISO 11202 Acoustics – Noise Emitted by Machinery and Equipment – Measurement of Emission Sound Pressure Levels at a Work Station and at Other Specified Positions – Survey Method in situ

ISO 11204 Acoustics – Noise Emitted by Machinery and Equipment – Measurement of Emission Sound Pressure Levels at a Work Station and at Other Specified Positions – Method Requiring Environmental Corrections

IEC 60086-2 Primary Batteries: Physical and Electrical Specifications

IEC 60384-14 Fixed Capacitors for Use in Electronic Equipment – Part 14: Sectional Specification – Fixed Capacitors for Electromagnetic Interference Suppression and Connection to the Supply Mains

IEC 60738-1 Thermistors – Directly Heated Positive Temperature Coefficient – Part 1: Generic Specification

IEC 60950-1 Information Technology Equipment – Safety – Part 1: General Requirements

IEC 61672-1 Electroacoustics – Sound Level Meters – Part 1: Specifications

IEC 61672-2 Electroacoustics – Sound Level Meters – Part 2: Pattern Evaluation Tests

IEC 62133 Secondary Cells and Batteries Containing Alkaline or Other Non-acid Electrolytes – Safety Requirements for Portable Sealed Secondary Cells and for Batteries Made From Them, For Use in Portable Applications

2.6 UL Standards:¹¹

UL-94 Standard for Safety of Flammability of Plastic Materials for Parts in Devices and Appliances Testing

⁹ Available from U.S. Government Printing Office Superintendent of Documents, 732 N. Capitol St., NW, Mail Stop: SDE, Washington, DC 20401, <http://www.access.gpo.gov>.

¹⁰ Available from International Organization for Standardization (ISO), 1 rue de Varembé, Case postale 56, CH-1211, Geneva 20, Switzerland, <http://www.iso.ch>.

¹¹ Available from Underwriters Laboratories (UL), 2600 N.W. Lake Rd., Camas, WA 98607-8542, <http://www.ul.com>.

⁸ Available from U.S. Consumer Product Safety Commission (CPSC), 4330 East West Hwy., Bethesda, MD 20814, <http://www.cpsc.gov>.

- UL 1642 Standard for Lithium Batteries
- UL 2054 Standard for Household and Commercial Batteries
- UL 62133 Secondary Cells and Batteries Containing Alkaline or Other Non-acid Electrolytes – Safety Requirements for Portable Sealed Secondary Cells and for Batteries Made From Them, For Use in Portable Applications
- ANSI/UL 1012 Power Units Other Than Class 2
- ANSI/UL 2595 General Requirements for Battery-Powered Appliances
- ANSI/UL 60950-1 Information Technology Equipment – Safety – Part 1: General Requirements

2.7 Canadian Standards:¹²

- CAN/CSA E62133 Secondary Cells and Batteries Containing Alkaline or Other Non-acid Electrolytes – Safety Requirements for Portable Sealed Secondary Cells and for Batteries Made From Them, For Use in Portable Applications

2.8 Other Documents:

- CTFA Microbiological Guidelines, Methods M-1 Determination of the Microbial Content of Personal Care Products¹³
- CTFA Microbiological Guidelines, Methods M-2 Examination for and Identification of *Staphylococcus aureus*, *Escherichia coli*, *Pseudomonas aeruginosa*, and *Candida albicans*¹³
- CTFA Microbiological Guidelines, Methods M-3 A Method for Preservation Testing of Water Miscible Personal Care Products

- CTFA Microbiological Guidelines, Methods M-6 A Method for Preservation Testing of Atypical Personal Care Products
- U.S. Food and Drug Administration Bacteriological Analytical Manual¹⁴
- United States Pharmacopeia, Volume 35 (or most current), Method 61 Microbiological Examination of Nonsterile Products: Microbial Enumeration Tests¹⁵
- United States Pharmacopeia, Volume 35 (or most current), Method 62 Microbiological Examination of Nonsterile Products: Tests for Specified Microorganisms¹⁵
- United States Pharmacopeia, Volume 35 (or most current), Chapter 1231 Water for Pharmaceutical Purposes¹⁵

3. Terminology

3.1 Definitions of Terms Specific to This Standard:

3.1.1 *A-weighted equivalent sound pressure level, L_{Aeq}* —the level of a steady-state sound which, in a stated time period and at a stated location, has the same A-weighted sound energy as the time-varying sound.

3.1.2 *accessible*—(part or component) describing any area of the toy that can be contacted by any portion forward of the collar of the accessibility probe as described in 16 CFR 1500.48 and 16 CFR 1500.49. (See Fig. 1.)

NOTE 1—Dimensions are provided in Fig. 1 for two probes corresponding to two age ranges of children.

3.1.3 *alkaline battery*—a non-rechargeable dry cell battery with an alkaline manganese electrochemistry.

¹⁴ Available from U.S. Food and Drug Administration (FDA), 10903 New Hampshire Ave., Silver Spring, MD 20993, <https://www.fda.gov/food/foodscienceresearch/laboratorymethods/ucm2006949.htm#intro>.

¹⁵ Available from U.S. Pharmacopeial Convention (USP), 12601 Twinbrook Pkwy., Rockville, MD 20852-1790, <http://www.usp.org>.

¹² Available from Canadian General Standards Board (CGSB), 11 Laurier St., Phase III, Place du Portage, Gatineau, Quebec K1A 0S5, Canada, <http://www.tpsgc-pwgsc.gc.ca/ongc-cgsb>.

¹³ Available from Personal Care Products Council (PCPC), 1620 L St., NW, Suite 1200, Washington, DC 20036, www.personalcarecouncil.org.

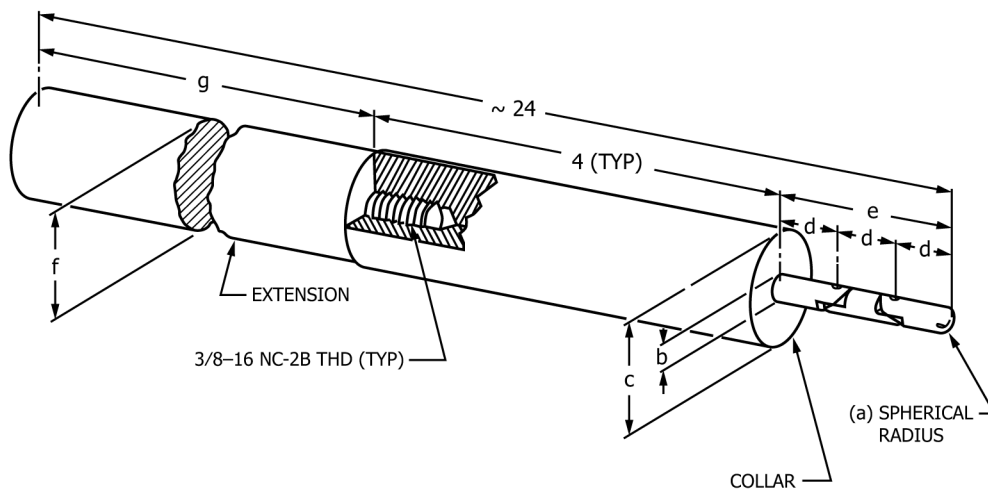

| | a | b | c | d | e | f | g |
|-----------------------------|--------------|------|-------|------|-------|-------|----------|
| (CHILDREN 0–36 MONTHS INCL) | PROBE A .110 | .220 | 1.020 | .577 | 1.731 | 1 | 18 9/32 |
| (" 37–96 " ") | PROBE B .170 | .340 | 1.510 | .760 | 2.280 | 1 1/2 | 17 25/32 |

ALL DIMENSIONS IN INCHES

FIG. 1 Accessibility Probes

3.1.4 *aquatic toy*—an article, whether inflatable or not, intended to bear the mass of a child and used as an instrument of play in shallow water. This does not include bath toys, beach balls, and United States Coast Guard-approved life saving devices.

3.1.5 *arrow*—projectile in the form of a shaft with a length of 150 mm or more that is intended to be discharged from a bow held by a child.

3.1.6 *art material*—any substance marketed or represented by the producer or repackager as suitable for use in any phase of the creation of any work of visual or graphic art of any medium. This definition includes items that become a component of the work of art such as paint, canvas, inks, crayons, chalk, solder, brazing rods, flux, paper, clay, stone, thread, cloth, and photographic film. It also includes items that are associated closely with the creation of the final work of art such as brushes, brush cleaners, solvents, ceramic kilns, silk screens, molds, mold making material, and photographic developing chemicals.

3.1.7 *ball*—any spherical, ovoid, or ellipsoidal object that is designed or intended to be thrown, hit, kicked, rolled, dropped, or bounced. The term “ball” includes any spherical, ovoid, or ellipsoidal object that is attached to a toy or article by means of string, elastic cord, or similar tether. The term “ball” also includes any multisided object formed by connecting planes into a generally spherical ovoid, or ellipsoidal shape that is designated or intended to be used as a ball. The term “ball” does not include dice, or balls permanently enclosed inside pinball machines, mazes, or similar outer containers. A ball is permanently enclosed if, when tested in accordance with 16 CFR 1500.53, it is not removed from the outer container.

3.1.8 *base material*—material upon which coatings may be formed or deposited.

3.1.9 *battery, button cell*—small round non-lithium battery, in which the overall height is less than the diameter.

3.1.9.1 *Discussion*—This definition is from ANSI C18.1M Part 1; these batteries are typically identified by a SR or LR designation; for example: SR44, LR44, SR45, LR45, SR54, LR54.

3.1.10 *battery, coin cell*—small round lithium battery, in which the overall height is less than the diameter.

3.1.10.1 *Discussion*—This definition is from ANSI C18.1M Part 1; these batteries are typically identified by a CR designation; for example: CR1620, CR2016, CR2020, CR2032, CR3032.

3.1.11 *battery-operated toy*—toy having at least one function dependent on electricity and powered by batteries.

3.1.12 *burr*—a roughness that may be found at an edge or joint of a toy or component if the material is not severed or finished cleanly.

3.1.13 *C-weighted peak sound pressure level, L_{Cpeak}* —the peak sound pressure level obtained when using standardized C-weighting.

3.1.14 *close-to-the-ear toy*—a toy that is intended to be used close to the ear, that is, the sound-emitting part of such a toy is

normally put against the ear of a child (example—toy telephones that emit sounds from the earpiece).

3.1.14.1 *Discussion*—While these toys may be held in the hand(s), they are distinguished from “hand-held” toys, as defined in 3.1.37, by their typical use distance.

3.1.15 *coating*—all layers of material formed or deposited on the base material or toy and includes paints, varnishes, lacquers, or other substances of a similar nature, whether they contain metallic particles or not, which can be removed by scraping with a sharp blade as defined under 16 CFR 1303, et seq.

3.1.16 *collapse*—sudden or unexpected folding of a structure.

3.1.17 *common household tool*—screwdriver (straight-blade or Phillips-type), pliers, coin, or other object commonly found in most households and which may be used to operate a screw, clip, or similar fixing device.

3.1.18 *compression spring*—spring which essentially returns to its initial state after compression.

3.1.19 *constant air inflatables*—structure relying on a continuous supply of air pressure supplied from one or more electrical blowers to maintain its shape, typically made of flexible fabric and designed for children’s use that may include but not be limited to the following activities: bounce, climb, slide, or interactive play.

3.1.20 *cord*—a length of slender, flexible material including monofilaments, woven and twisted cord, rope, plastic textile tapes, ribbon, and those fibrous materials commonly called string.

3.1.21 *cosmetics*—for the purposes of this standard, cosmetics are items meeting the Federal Food, Drug, and Cosmetics Act definition of a cosmetic (“any articles intended or likely to be rubbed, sprinkled, or sprayed on, introduced onto, or otherwise applied to the human body for cleansing, beautifying, promoting or enhancing attractiveness, or for altering appearance”) that are sold as part of or included with a toy, including such items sold for imitative or “dress-up” play, as well as similar items which are intended to be applied to a toy (examples: eye shadow or lip gloss intended to be applied to a doll’s face; such items are not subject to FDCA labeling requirements). “Cosmetics” also includes temporary tattoos.

3.1.22 *crushing*—injury to part of the body resulting from compression between two rigid surfaces.

3.1.23 *curled edge*—an edge in which the portion of the sheet adjacent to the edge is bent into an arc and forms an angle of less than 90° with the base sheet, as shown in Fig. 2.

3.1.24 *detection limit of a method*—three times the standard deviation of the blank value.



FIG. 2 Curled Edge

3.1.25 *discharge mechanism*—a component(s) of the toy which releases or propels the projectile into free flight.

3.1.26 *edge, hazardous*—an accessible edge that presents an unreasonable risk of injury during the normal use and reasonably foreseeable abuse of a toy. Metal and glass edges on toys intended for children under the age of eight years are defined as potentially hazardous if they fail the sharp edge test described in 16 CFR 1500.49. Edges other than metal and glass are defined as potentially hazardous if they are sharp to the touch under casual handling conditions.

3.1.27 *elastic*—material that will recover its former size and shape essentially and instantaneously after being elongated at least 10 % at a testing speed of not less than 20 in. (510 mm)/min.

3.1.28 *expanding material*—any material used in a toy which expands greater than 50 % in any dimension from its as-received state when tested in accordance with 8.30.

3.1.29 *explosive action*—the sudden release of energy characterized by the rapid expansion or bursting of a material.

3.1.30 *extension spring*—spring which essentially returns to its initial state after tension.

3.1.31 *fastener*—mechanical device which attaches two or more elements together (for example, screws, rivets, and staples).

3.1.32 *feathering*—the beveling of an edge (or decrease in thickness moving toward the edge) caused during the shearing or cutting of material.

3.1.33 *flash*—excess material that escapes between the mating parts of a mold assembly.

3.1.34 *folding mechanism*—an assembly of hinged, pivoted, folding, or sliding members that can produce a crushing, scissoring, pinching, or shearing action during operation.

3.1.35 *free flight*—unconstrained travel caused by a force, other than gravity alone, through the air in a trajectory regardless of whether the travel is ultimately constrained by means of a tether (for example, pop-gun).

3.1.36 *fuzz*—bits of fibrous-type material that can be readily removed from toys with a pile surface.

3.1.37 *hand-held toy*—a toy that is intended to be used or operated while being held in the hand. Examples include toy tools, small electronic games, stuffed animals, dolls, musical toys, and cap-firing toys.

3.1.37.1 *Discussion*—This definition does not include close-to-the-ear toys, as defined in 3.1.14.

3.1.38 *hazard*—any characteristic of a toy that presents an unreasonable risk of injury or illness during normal use or as a result of reasonably foreseeable abuse.

3.1.39 *hazardous magnet*—a magnet which is a small object (refer to 4.6 and Fig. 3) and which has a flux index ≥ 50 (as determined in accordance with the test method in 8.25.1).

3.1.40 *hazardous magnetic component*—any part of a toy that is a small object (refer to 4.6 and Fig. 3) and which contains an attached or imbedded magnet which has a flux index ≥ 50 (as determined in accordance with the test method in 8.25.1).

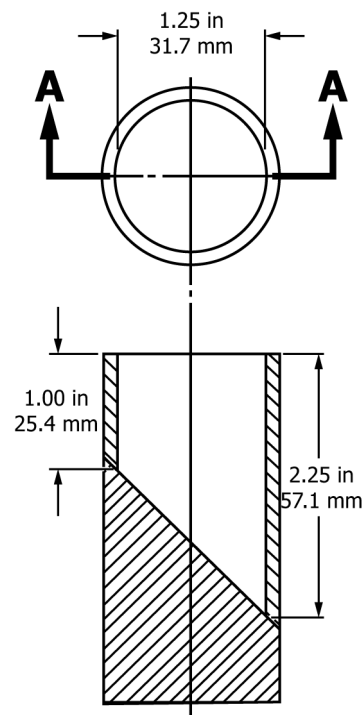

FIG. 3 Small Parts Cylinder

3.1.41 *helical spring*—spring in the form of a coil.

3.1.42 *hemmed edge*—an edge in which the portion of the sheet adjacent to the edge is folded back on the sheet itself through an angle of approximately 180°, so that the portion of the sheet adjacent to the edge is approximately parallel to the main sheet, as shown in Fig. 4.

3.1.43 *hinge-line clearance*—the distance between the stationary portion of a toy and the movable portion along, or adjacent to, a line projected through the axis of rotation, shown as Dimension A in Fig. 5.

3.1.44 *juvenile products*—consumer products designed or intended primarily for use by children which are not used primarily for play. These include, but are not limited to, items such as bassinets/cradles, bath seats, infant bath tubs, carriages and strollers, changing tables, full size cribs, gates and enclosures, handheld infant carriers, high chairs, infant bouncers, infant swings, play yards/non-full size cribs, portable bed rails, portable hook-on chairs, soft infant carriers, stationary activity centers, toddler beds and walkers.

3.1.45 *lap joint*—a joint in which an edge overlaps a parallel surface but is not necessarily attached to it mechanically at all points along the length, as in the examples shown in Fig. 6.

3.1.46 *large and bulky toy*—toy that has a projected base area of more than 400 in.² (0.26 m²) or a volume of more than 3 ft³ (0.08 m³) calculated without regard to minor appendages.



FIG. 4 Hemmed Edge

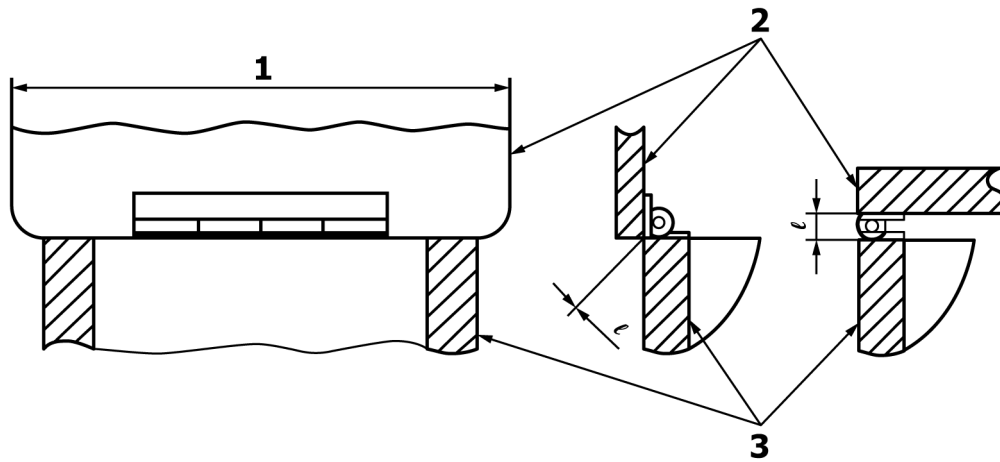

Key

- 1 Hinge line
- 2 Lid
- 3 Box

l = Hinge-line clearance

FIG. 5 Changing Clearance at Hinge Line



FIG. 6 Typical Lap Joints

NOTE 2—The base area for toys having permanently attached legs is measured by calculating the area enclosed by straight lines connecting the outermost edge of each leg of the perimeter.

3.1.47 *latex balloon*—any toy or decorative item consisting of a latex bag that is designed to be inflated by air or gas. The term does not include inflatable children’s toys that are used in aquatic activities such as rafts, water wings, swim rings, or other similar items.

3.1.48 *leading edge(s)*—the location(s) on or area(s) of the projectile (for example, tips, edges, or protrusions), which would be expected to make contact with the eyeball in the event of an intentional or unintended launch toward the eye.

3.1.48.1 *Discussion*—This would include all areas that could reasonably be expected to strike the eye in situations where the projectile may travel in unpredictable orientations (for example, tumbling). In determining whether an edge can strike the eye, the size and spherical shape of the eye should be considered.

3.1.49 *magnetic/electrical experimental set*—toy containing one or more magnets intended for carrying out educational experiments involving both magnetism and electricity.

3.1.50 *marble*—a sphere made of a hard material, such as glass, agate, marble, or plastic, that is used in various children’s games, generally as a playing piece or marker. The term “marble” does not include a marble permanently enclosed in a

toy or game. A marble is permanently enclosed if, when tested in accordance with 16 CFR 1500.53, it is not removed from the toy or game.

3.1.51 *materials intended to leave a trace*—graphite material in pencils, liquid in pens, and similar substances.

3.1.52 *maximum A-weighted sound pressure level, L_{AFmax}* —the maximum sound pressure level obtained when using standardized A-weighting and fast detector response (time-weighting).

3.1.53 *non-replaceable battery*—an electrochemical device that is not consumer accessible, is not intended to be replaced after the useful life of the battery, and is not accessible when tested in accordance with the normal use and, where appropriate, reasonably foreseeable abuse tests.

3.1.53.1 *Discussion*—Reasonably foreseeable abuse tests are included in 8.6 – 8.10.

3.1.54 *normal use*—play modes that conform to the instructions accompanying the toy, that have been established by tradition or custom, or that are evident from an examination of the toy.

3.1.55 *other materials, whether mass colored or not*—materials such as wood, leather, and other porous substances which may absorb coloring matter without forming a coating.

3.1.56 *packaging*—material accompanying the toy when purchased, but having no intended play function.

3.1.57 *pinching*—created when two moving or one moving and one fixed surface come together in such a way that they could entrap and compress flesh, usually resulting in a contusion or laceration.

3.1.58 *point, hazardous*—an accessible point that presents an unreasonable risk of injury during normal use or reasonably foreseeable abuse. Points on toys intended for children under the age of 8 years are potentially hazardous if they fail the sharp point test described in 16 CFR 1500.48.

3.1.59 *pompom*—lengths or strands of fiber, yarns, or threads clamped or secured and tied in the center, and brushed up to form a spherical shape. Also included are spherical-shaped attachments made of stuffed material.

3.1.60 *primary battery*—one or more primary cells, including case, terminals, and markings.

3.1.61 *primary cell*—basic functional unit providing a source of electrical energy by direct conversion of chemical energy, which consists of an assembly of electrodes, separators, electrolyte, container, and terminals, and that is not designed to be electrically recharged.

3.1.62 *principal display panel*—the display panel for a retail package or container, bin, or vending machine that is most likely to be displayed, shown, presented, or examined under normal or customary conditions of display for retail sale.

3.1.63 *projectile*—an object intended to be launched into a free flight.

3.1.63.1 *Discussion*—This does not include self-propelled flying toys such as remote control helicopters and wind-up airplanes. (See Rationale for additional explanation.)

3.1.64 *projectile toy with stored energy*—toy with a projectile launched by means of a discharge mechanism capable of storing energy independent of the user and typically requiring at least one discrete action by the user to launch the projectile.

3.1.64.1 *Discussion*—This includes toy rockets and similar toys propelled by a chemical reaction or compressed gasses (for example, air) where the energy can be stored independent of the user. For example, in a rocket propelled by a mixture of vinegar and baking soda, the user initiates the reaction by mixing the two substances but no longer has control of the actual launching. The rocket will launch when the pressure build up overcomes the force that holds the rocket onto the launch platform.

3.1.65 *projectile toy without stored energy*—toy with a projectile propelled by energy imparted by the user or by means of a discharge mechanism incapable of storing energy independent of the user.

3.1.66 *projection, hazardous*—a projection that, because of its material or configuration, or both, may present a puncture hazard if a child should fall onto it. Excluded from this definition are puncture hazards to the eyes or mouth, or both, because of the impossibility of eliminating puncture hazards to those areas of the body by product design.

3.1.67 *protective cap or cover*—a component that is attached to a potentially hazardous edge or projection to reduce the possibility of injury.

3.1.68 *protective tip*—a component that is attached to the impacting end of a projectile to minimize injury if it should impact on the body, and also to prevent damage to the projectile upon striking a target, provide a means of attaching the projectile to the target as in the case of suction cups, or prevent damage to inanimate objects.

3.1.69 *push or pull toy*—a toy with a cord, tether, or handle attached to the toy and where the toy is intended for use on the floor or ground with the child in a standing/upright position, typically walking, while pushing or pulling the toy.

3.1.70 *rattle*—a toy that is clearly designed to emit sound when shaken and typically intended for children under 18 months.

3.1.71 *reasonably foreseeable abuse*—conditions to which a child may subject a toy that are not normal use conditions, such as deliberate disassembly, dropping, or using the toy for a purpose for which it was not intended. Simulated use and abuse tests for toys are given in 16 CFR 1500.50-53 (excluding the bite test, Paragraph (c), of each section).

3.1.72 *reference box*—a hypothetical surface which is the smallest rectangular parallelepiped that encloses the toy without regard to minor appendages.

3.1.73 *removable component*—a component of a toy which is intended or likely to be removed by the child during normal use.

3.1.74 *resilient leading edge*—a leading edge of a projectile made with any material having a Shore A scale durometer of 70 or less.

3.1.74.1 *Discussion*—The measurement shall be performed in accordance with the latest revision of Test Method D2240.

3.1.75 *rigid*—any material having a hardness greater than 70 Shore A scale durometer, as measured by the latest revision of Test Method D2240.

3.1.76 *rigid leading edge*—a leading edge of a projectile made with any material having a Shore A scale durometer greater than 70.

3.1.76.1 *Discussion*—The measurement shall be performed in accordance with the latest revision of Test Method D2240.

3.1.77 *rolled edge*—an edge in which the portion of the sheet adjacent to the edge is bent into an arc and forms an angle between 90 and 120° with the main sheet, as shown in Fig. 7.

3.1.78 *scraping*—mechanical removal of coatings down to the base material without damaging the substrate material.

3.1.79 *secondary battery*—assembly of secondary cell(s) ready for use as a source of electrical energy characterized by its voltage, size, terminal arrangement, capacity, and rate capability.

3.1.80 *secondary cell*—basic functional unit providing a source of electrical energy by direct conversion of chemical energy, which consists of electrodes, separators, electrolyte, container and terminals, and that is designed to be electrically recharged.

3.1.81 *simulated protective equipment*—toys designed to mimic products that infer some sort of physical protection to the wearer (for example, protective helmets and visors).

3.1.82 *soft-filled toy/stuffed toy*—toy, clothed or unclothed, with soft body surfaces and filled with soft materials, allowing compression of the torso readily with the hand.

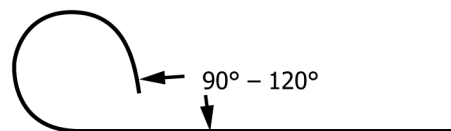

FIG. 7 Rolled Edge

3.1.83 *splinter*—sharp pointed fragment.

3.1.84 *spiral spring*—clockwork-type spring.

3.1.85 *squeeze toy*—a handheld pliable toy, intended for children under the age of 18 months, usually incorporating a noise-making feature activated by forcing air through an opening when flexed or squeezed, and which recovers to its original shape when released.

3.1.86 *steady-state sound (noise)*—noise in which there are negligibly small fluctuations of sound pressure level within the period of observation.

3.1.87 *strap*—a piece of flexible material in which the width is significantly greater than the thickness.

3.1.88 *substrate material*—all of the accessible materials present in toys, other than paint or similar surface coatings.

3.1.89 *tabletop, floor, or crib toy*—toys intended to be used atop a table, on the floor or ground, or on or attached to a crib; the child can be sitting or standing at the table; sitting, kneeling, or lying on the floor or ground; or sitting, lying, or standing in a crib while the toy is in use.

3.1.89.1 *Discussion*—These toys can remain stationary, be self-propelled, be user-propelled, or any combination of these modes. Examples of tabletop, floor, or crib toys include, but are not limited to, toy vehicles, stacking toys, games, large and bulky toys, and activity toys that attach to crib rails. This definition does not include push or pull toys, as defined in 3.1.69.

3.1.90 *tangle or form a loop*—loops that are formed by reasonably foreseeable manipulation of the cord/strap/elastic. Loops that are formed by excessive or intricate manipulations, or both, of the cord/strap/elastic shall be considered as exempt.

3.1.91 *teether*—toy designed for oral use and intended primarily for symptomatic relief of teething discomfort.

3.1.92 *toy*—any object designed, manufactured, or marketed as a plaything for children under 14 years of age.

3.1.93 *toy chest*—toy boxes that are designed and marketed as storage containers for toys. The products subject to the requirements are those with a volume of 1.1 ft³ (0.031 m³) or more.

3.1.94 *toy seat*—a stationary toy product with a seat where the amusement of the child is a primary function of the product and the play pattern intends that the child be in a seated position.

3.1.94.1 *Discussion*—Play features may include, but are not limited to, sliding or rotating features, learning toys, manually actuated music etc. with which the seated child may interact. Children’s furniture products without any interactive play features such as stools, chairs, patio sets, rocking chairs, picnic tables, storage units etc. are not considered toy seats. In addition, juvenile products such as bouncers, infant seats, stationary activity centers etc. are not considered toy seats.

3.1.95 *yo yo elastic tether toy*—a toy consisting of an elastic tether that usually contains a loop on one end to wear around the finger, and a flexible object on the other end intended to be thrown and returned to the hand.

4. Safety Requirements

4.1 *Material Quality*—Toys may be made from new or reprocessed materials and shall be visually clean and free from infestation. The materials shall be assessed visually by the unaided eye rather than under magnification. If reprocessed materials are used, they shall be refined so that the level of hazardous substances conforms to the requirements of 4.3.1.

4.2 *Flammability*—Materials other than textiles (excluding paper) used in toys shall not be flammable, as defined under 16 CFR 1500.3(c)(6)(vi) under the Federal Hazardous Substances Act (FHSA) (see 16 CFR 1500). For testing purposes, any textile fabrics used in toys shall comply with 16 CFR 1610. A test procedure for testing flammability of toys, which is an interpretation of 16 CFR 1500.44, is contained in Annex A5. A procedure for testing the flammability of fabrics is contained in Annex A6.

4.3 *Toxicology:*

4.3.1 *Hazardous Substances*—Toys or materials used in toys shall conform to the FHSA and to the regulations promulgated under that act. Exemptions to this act for certain types of toys are given in 16 CFR 1500.85. The regulations define limits for substances that are toxic, corrosive, an irritant, sensitizer or pressure generating, and radioactive, flammable, and combustible materials. Testing references for hazardous substance content are given in 8.2. It should be noted that specific states may have hazardous substances regulations that are more restrictive than the Federal regulations.

4.3.2 *Manufacturing and Packaging of Food*—All food products supplied with toys shall be manufactured and packaged in compliance with 21 CFR 110, which is concerned with the sanitation practices for the manufacture, processing, packaging, or holding of human food.

4.3.3 *Indirect Food Additives*—Toy components intended to be used in contact with food, such as toy cooking utensils, shall conform to the applicable requirements of the Food, Drug and Cosmetic Act (FDCA), specifically 21 CFR 170 through 189.

4.3.3.1 *Toys in Contact with Food*—Toys comprising components intended to be used in contact with food, such as toy cooking utensils and toy tableware shall meet the requirements of 6.7 for instructional literature.

4.3.3.2 *Ceramicware, Lead, and Cadmium Contamination*—Ceramic toy components intended or likely to hold food, such as a porcelain tea set, shall conform to the applicable requirements of the FDCA, Section 402 (a) (2) (c), and FDA Compliance Policy Guides.

4.3.4 *Cosmetics*—Cosmetics shall conform to the requirements of the Federal FDCA as codified in 21 CFR. The regulations applicable to cosmetics are stated in 21 CFR 700 through 740. The color additive regulations applicable to cosmetics are found in 21 CFR 73, 74, 81, and 82.

4.3.4.1 In addition, cosmetics intended for use by children under 8 years of age shall meet all requirements of this specification and the FHSA regulations, notwithstanding the exclusions of 16 CFR 1500.81 and 1500.3(b)(4)(ii).

4.3.4.2 The requirements from the Food and Drug Administration (FDA) will therefore be additive to those existing for children’s products.

4.3.5 Heavy Elements:

NOTE 3—While it is anticipated that the majority of testing to establish compliance with the heavy elements requirements of this standard will be conducted on complete toy samples, it is also acceptable to confirm compliance by testing of raw materials or components, or both, so long as it can be established that the results so obtained are representative of those which would be obtained by testing finished items; that is, this latter approach is only valid when it is determined that: (1) the manufacturing process does not in any way affect the test results obtained; and (2) the materials tested are representative of those in the final toy. For example, if the above conditions are met, it would be possible to demonstrate compliance with this standard for a surface coating by applying the coating to a clean glass plate, allowing it to dry, then testing the scraped-off material per section 8.3.1.

As noted above, the production process subsequent to component testing can in some instances have a significant impact on compliance, sometimes causing components previously tested and found to be compliant to become noncompliant. Those opting to test raw materials or components in lieu of finished items should take great care to be certain that results on components remain valid for the finished item, and be aware that results obtained in this manner may differ from those obtained on finished toys for a variety of reasons; among the most common are: (1) Substitution of raw materials occurring during production; (2) Contamination of the raw material occurring during production (for example, spray guns contaminated by lead used to apply compliant paint thereby rendering it noncompliant, use of contaminated thinners or solvents to thin paint or clean silk screens, etc.); (3) Migration of elements and their compounds from substrate (especially plasticized ones) to surface coating.

While component testing is an entirely valid approach, care shall be exercised to be certain that the production process subsequent to component testing does not create any change which might affect compliance.

4.3.5.1 Paint and Similar Surface-coating Materials—Paint and other similar surface-coating materials applied to toys shall comply with the lead content provisions of 16 CFR 1303, issued under the Consumer Product Safety Act (CPSA), as amended by the Consumer Product Safety Improvement Act of 2008 (CPSIA).

(1) This regulation prohibits the use of paints or similar surface-coating materials that contain lead or lead compounds and in which the lead content (calculated as lead metal (Pb)) is in excess of 0.009 % (90 ppm) of the weight of the total nonvolatile content of the paint or the weight of the dried paint film.

(2) In addition, surface-coating materials shall not contain compounds of antimony, arsenic, barium, cadmium, chromium, lead, mercury, or selenium, of which the metal content of the soluble material is in excess of the levels by weight of the contained solids (including pigments, film solids, and driers) given in Table 1. The analytical results obtained should be adjusted in accordance with the test method in 8.3.4.3 prior to comparing them to the values in Table 1. To determine conformance, the soluble level shall be determined by dissolving the contained solids (dried film including pigments, film solids, and driers) as specified in 8.3.2.

TABLE 1 Maximum Soluble Migrated Element in ppm (mg/kg) for Surface Coatings and Substrates Other Than Modeling Clay Included as Part of a Toy

| Antimony (Sb) | Arsenic (As) | Barium (Ba) | Cadmium (Cd) | Chromium (Cr) | Lead (Pb) | Mercury (Hg) | Selenium (Se) |
|------------------|-----------------|----------------|-----------------|------------------|--------------|-----------------|------------------|
| 60 | 25 | 1000 | 75 | 60 | 90 | 60 | 500 |

4.3.5.2 Toy Substrate Materials—These requirements are intended to reduce children’s exposure to heavy elements potentially contained in accessible toy substrate materials.

(1) Toy substrate materials shall conform to the requirements and test methods for total lead and the migration of antimony, arsenic, lead, barium, cadmium, chromium, mercury, and selenium in accessible substrate materials. For accessible glass, metal, and ceramic toys or parts of toys, the migration testing requirements are only applied if they are small parts (that is, they fit completely within the test fixture specified at 16 CFR 1501) (see Fig. 3).

(a) Accessibility of parts shall be determined as defined in 3.1.2 before and after use and abuse testing described in 8.5 – 8.10. See Note 4.

(b) Toys and parts of toys which, due to their inaccessibility, size, mass, function, or other characteristics, cannot be sucked, mouthed, or ingested are not subject to the migration testing requirements. See Note 5 and Note 6.

NOTE 4—For the purposes of this requirement, paint, coatings, or electroplating are not considered as barriers to accessibility. In addition, fabric coverings of toys or components shall not be considered a barrier to accessibility if any dimension of the covered toy or component measures less than 5 cm, or if a fabric material does not withstand testing per 8.7 – 8.10 sufficiently to prevent the internal component(s) from becoming accessible.

NOTE 5—For the purposes of this requirement, the following criteria are considered reasonably appropriate for the classification of toys or parts likely to be sucked, mouthed, or ingested: (1) All toy parts intended to be mouthed or contact food or drink, components of toys which are cosmetics, and components of writing instruments categorized as toys; (2) Toys intended for children less than 6 years of age, that is, all accessible parts and components where there is a probability that those parts and components may come into contact with the mouth.

NOTE 6—The CPSIA-mandated total lead in substrate requirement applies to all accessible parts or components of toys, unless exempted as outlined in (f) and (g) below, for ages 12 years and under, regardless of whether they can be mouthed, licked, or sucked.

(c) Packaging materials are not subject to these requirements unless they are intended to be retained as part of the toy or are intended to provide play value.

(d) These requirements are not intended to apply to children’s jewelry, which is addressed by Specification F2923.

(e) Paper and paperboard are not subject to these requirements.

(1) Stickers consisting of a paper substrate with no laminate coating (that is, those that consist solely of paper and ink, with or without adhesive, along with any varnish or topcoat which is absorbed into the substrate and becomes inseparable from it, and is not a plastic film) are exempt from substrate testing under the paper exemption. Stickers which are printed on a plastic or other nonporous substrate or have a laminated plastic coating are to be tested as a single polymeric material per 8.3.5.4. If scrapeable, the ink or other surface coating is tested as a surface coating and the underlying substrate is tested separately unless the substrate is exempt because it is composed of paper. Pressure-sensitive adhesive (either standard or low-tack as that used for repositionable (for example, 3M brand “Post-it” note paper) applications) applied to a porous substrate is not a surface coating as defined (see 16 CFR 1303.2(b)(1)) in that it does not dry to a solid film, but instead exists as a viscous liquid (primarily on the surface of

the substrate, but also becoming inseparable from it due to “wicking” by capillary action). Since pressure-sensitive adhesives are not likely to contain appreciable amounts of any of the proscribed heavy elements, they are exempt from testing except when inseparable from and tested as part of a composite substrate.

(f) Materials that are the subject of exemptions listed in the most current version of 16 CFR 1500.88 are excluded from the lead-related requirements of this section. See **Note 7**.

(g) Materials that are the subject of determinations listed in the most current revision(s) of 16 CFR 1251, 16 CFR 1252, 16 CFR 1253, or 16 CFR 1500.91 as exempt from testing and certification requirements are excluded from the requirements of this section. See **Note 8**.

(h) Printed textiles where the printing can be easily separated (for example, pigment prints and screen inks) should have the printed matter removed and tested separately as a surface coating, and the remaining textile substrate tested per **8.3.5.4**. All other textiles (for example, unprinted/undyed fabrics, textiles where the printed matter cannot be easily separated, such as mass-dyed polymeric fibers, fiber-reactive prints on cellulosic fabrics, discharge printing of either mass or reactive dyed fabric, etc.), the entire material should be tested as a single item per **8.3.5.4**.

NOTE 7—These exemptions are both material- and element-specific and should be examined with care. 16 CFR 1500.88 exempts certain materials from total lead requirements; these exemptions are also extended to lead migration testing for the purposes of this standard.

NOTE 8—These determinations are both material- and element-specific and should be examined with care. Determinations only remove the CPSIA-mandated requirement for third-party testing and certification; they do not alter the requirement to comply with relevant heavy element limits.

(2) *Requirements:*

(a) Accessible component parts of children’s products, before and after use and abuse testing described in **8.5 – 8.10** and in 16 CFR 1500.50-53 and 16 CFR 1500.87, shall not contain lead or lead compounds in which the lead content (calculated as lead metal (Pb)) is in excess of 0.01 % (100 ppm) of the weight of the component.

(b) The migration of elements from toys and parts of toys as specified in **4.3.5.2(1)** shall not exceed the limits specified in **Table 1** when tested in accordance with the methods set forth in **8.3**. The analytical results obtained should be adjusted in accordance with the test method in **8.3.4.3** prior to comparing them to the values in **Table 1**.

(c) Modeling clays included as part of a toy shall not exceed the limits specified in **Table 2** when tested in accordance with the methods set forth in **8.3**. The analytical results obtained should be adjusted in accordance with the test method in **8.3.4.3** prior to comparing them to the values in **Table 2**.

TABLE 2 Maximum Soluble Migrated Element in ppm (mg/kg) for Modeling Clays Included as Part of a Toy

| Antimony (Sb) | Arsenic (As) | Barium (Ba) | Cadmium (Cd) | Chromium (Cr) | Lead (Pb) | Mercury (Hg) | Selenium (Se) |
|---------------|--------------|-------------|--------------|---------------|-----------|--------------|---------------|
| 60 | 25 | 250 | 50 | 25 | 90 | 25 | 500 |

(d) In addition, metallic toys or metallic toy components which are small parts may not exhibit extraction of more than 200 µg of cadmium when tested per **8.3.5.5(3)**.

(e) Alternatively, it is permitted to establish compliance with the requirements of (a), (b), (c), and (d) by a screening of total element content as specified in **8.3.1**. If total cadmium level in the screening test is below 75 ppm, the item or component is to be deemed compliant with the cadmium requirement of (d) above.

4.3.6 Cosmetics, Liquids, Pastes, Putties, Gels, Powders, and Items of Avian Feather Origin—The purpose of this requirement is to minimize the risks associated with potential lack of cleanliness, shelf life degradation, and contamination in use of cosmetics, liquids, pastes, putties, gels, powders, and items of avian feather origin (example: “marabou” items derived from poultry feathers) used in toys (excluding art materials). It sets standards for cleanliness and the ability to withstand extended shelf life or contamination, or both, during use without microbiological degradation.

4.3.6.1 Process water used in the manufacturing and filling of toys shall comply with the bacteriological standards for USP Purified Water (USP 35, or the most recent edition of the USP, <1231>) as well as for drinking water per the EPA standard (40 CFR 141.63); specifically, this requires a heterotrophic plate count of <10 colony forming units per milliliter (cfu/ml) and the absence by test of coliform bacteria.

NOTE 9—The various methods for producing purified water each present different potentials for contaminating the final product. Purified water produced by distillation is sterile, provided that the production equipment is suitable and sterile. On the other hand, ion-exchange columns, microfiltration units, and reverse osmosis units require special attention in that they afford sites for microorganisms to foul the system and contaminate the effluent. Frequent monitoring may thus be called for, particularly with the use of these units following periods of shutdown of more than a few hours.

4.3.6.2 The formulations of these products used in toys shall be such that they are not subject to microbial degradation during shelf life or reasonably foreseeable use.

4.3.6.3 The cleanliness of these products used in toys and their ingredients shall be determined in accordance with **8.4.1**.

4.3.6.4 Formulations of these products (except avian feather items) shall be evaluated for potential microbiological degradation in accordance with **8.4.2**.

4.3.7 Stuffing Materials—Loose fillers for stuffed toys shall be free of objectionable matter originating from insect, bird, rodent, or other animal infestation and of contaminants, such as splinters, glass and metal chips to the extent possible in good manufacturing practice when evaluated in accordance with **8.29**.

4.3.8 Phthalates—Toys (including pacifiers, rattles, and teethers) for children 12 years of age and younger shall not contain more than 0.1 % (1000 ppm) concentration of any of the phthalates restricted by 16 CFR 1307 in any accessible plasticized component.

NOTE 10—Accessibility to be determined in accordance with 16 CFR 1199.1.

4.3.8.1 Testing for compliance is to be conducted in accordance with CPSC test method CPSC-CH-C1001-09.4 or the most recent revision of that test procedure.

NOTE 11—The CPSC test method referenced in 4.3.8.1 allows the use of multiple alternative test protocols (with appropriate modifications) for increased flexibility.

4.3.8.2 While all accessible toy components subject to the requirements of 4.3.8 shall be in compliance, CPSC has determined that components composed of certain materials do not require third-party testing; these materials determinations are codified at 16 CFR 1252, 16 CFR 1253, and 16 CFR 1308.

4.4 *Electrical/Thermal Energy*—Toys operating from nominal 120-V branch circuits shall conform to 16 CFR 1505, issued under the FHSA.

4.5 *Sound-producing Toys*—These requirements are intended to minimize the possibility of hearing damage that might be caused by toys that are designed to produce sound. These requirements are applicable before and after testing in accordance with 8.5 through 8.10. For toys intended for children up to 14 years of age, both the acoustics and use and abuse requirements are to be applied. For toys for ages 8 years to 14 years, the use and abuse requirements appropriate to a child 36 months to 96 months of age are to be applied. These acoustic requirements do not apply to: (1) sounds produced by mouth-actuated toys where the sound pressure level is determined by the blowing action of the child; (2) sounds such as those produced by xylophones, bells, drums, and squeeze toys where the sound pressure level is determined by the muscular action of the child (this exemption does not apply to rattles which shall conform to the requirement in 4.5.1.3); (3) sounds produced by radios, MP3 players, CD players, and other similar electronic toys and toys where the sound output is dependent on the content of removable media such as discs, flash cards, or internet downloaded content; (4) sounds produced by toys that are connected to or interfaced with external devices such as televisions and computers where the sound pressure level is determined by the external device; (5) sound emitted from earphones/headphones; or (6) sounds produced by toys that reproduce or alter the child's voice such as walkie-talkies, recording devices, megaphones, karaoke players, voice-altering electronic toys, etc.

4.5.1 *Requirements*—Toys that are designed to emit sound shall conform to the requirements of 4.5.1.1 through 4.5.1.7 as applicable. If the toy has features that allow it to fit into multiple categories below, it shall be tested to all applicable requirements. For example, a stacking toy with a rattle and a push-button activated sound would be tested to both the requirement for rattles (4.5.1.3) and the requirements for stationary or self-propelled tabletop, floor, or crib toys (4.5.1.4). Toys that do not clearly fit in any of the categories listed shall conform to the most appropriate requirement(s); a general rule when determining most appropriate requirement(s) is to consider how the sound is produced and the typical acoustical use distance.

NOTE 12—See A14.4 for additional information.

4.5.1.1 *Close-to-the-ear Toys:*

(1) The A-weighted equivalent sound pressure level, L_{Aeq} , produced by close-to-the-ear toys shall not exceed 65 dB when tested per 8.20.2.1.

(2) The C-weighted peak sound pressure level, L_{Cpeak} , produced by close-to-the-ear toys shall not exceed 110 dB when tested per 8.20.2.1.

4.5.1.2 *Hand-held Toys:*

(1) The A-weighted equivalent sound pressure level, L_{Aeq} , produced by hand-held toys, *excluding* rattles, shall not exceed 85 dB when tested per 8.20.2.2.

(2) The C-weighted peak sound pressure level, L_{Cpeak} , produced by hand-held toys, *excluding* both rattles and sounds produced by explosive action (for example, percussion caps), shall not exceed 115 dB when tested per 8.20.2.2. Sounds produced by explosive action of hand-held toys shall conform to the L_{Cpeak} requirement in 4.5.1.7.

4.5.1.3 *Rattles*—The C-weighted peak sound pressure level, L_{Cpeak} , produced by rattles shall not exceed 115 dB when tested per 8.20.2.3.

4.5.1.4 *Stationary or Self-propelled Tabletop, Floor, or Crib Toys:*

NOTE 13—Such toys may be usable in a stationary or a self-propelled mode, or both; if both modes are applicable to the toy, it is to be tested separately in each mode. User-propelled versions/modes are addressed in 4.5.1.5.

(1) The A-weighted equivalent sound pressure level, L_{Aeq} , produced by tabletop, floor, or crib toys when in stationary or self-propelled modes shall not exceed 85 dB when tested per 8.20.2.4.

(2) The C-weighted peak sound pressure level, L_{Cpeak} , produced by tabletop, floor, or crib toys in stationary or self-propelled modes, *excluding* sounds produced by explosive action (for example, percussion caps), shall not exceed 115 dB when tested per 8.20.2.4. Sounds produced by explosive action of tabletop, floor, or crib toys in stationary or self-propelled modes shall conform to the L_{Cpeak} requirement in 4.5.1.7.

4.5.1.5 *User-propelled Tabletop, Floor, or Crib Toys:*

(1) The maximum A-weighted sound pressure level, L_{AFmax} , produced by tabletop, floor, or crib toys in user-propelled modes, where the sound is created as a result of translational motion imparted on the toy by the user (for example, a mechanical sound-producing mechanism attached to the axle of a toy vehicle), shall not exceed 85 dB when tested per 8.20.2.5.

(2) The C-weighted peak sound pressure level, L_{Cpeak} , produced by tabletop, floor, or crib toys in user-propelled modes, where the sound is caused as a result of translational motion imparted on the toy by the user (for example, a mechanical sound-producing mechanism attached to the axle of a toy vehicle), *excluding* sounds produced by explosive action (for example, percussion caps), shall not exceed 115 dB when tested per 8.20.2.5. Sounds produced by explosive action of tabletop, floor, or crib toys in user-propelled modes caused as a result of translational motion imparted on the toy by the user shall conform to the L_{Cpeak} requirement in 4.5.1.7.

4.5.1.6 *Push or Pull Toys:*

(1) The A-weighted equivalent sound pressure level, L_{Aeq} , produced by push or pull toys in stationary or self-propelled modes, *excluding* those created by explosive action (for example, percussion caps) shall not exceed 85 dB when tested per 8.20.2.4. Each mode, if applicable to the toy, is to be tested

separately. The maximum A-weighted sound pressure level, L_{AFmax} , produced by push or pull toys where the sound is caused as a result of translational motion imparted on the toy by the user (for example, a sound-producing mechanism attached to an axle of a pull toy) shall not exceed 94 dB when tested per 8.20.2.5.

(2) The C-weighted peak sound pressure level, L_{Cpeak} , produced by push or pull toys in stationary or self-propelled modes, *excluding* sounds produced by explosive action (for example, percussion caps), shall not exceed 115 dB when tested per 8.20.2.4. Each mode, if applicable to the toy, is to be tested separately. The C-weighted peak sound pressure level, L_{Cpeak} , produced by push or pull toys where the sound is caused as a result of translational motion imparted on the toy by the user (for example, a mechanical sound-producing mechanism attached to an axle of a pull toy), *excluding* sounds produced by explosive action (for example, percussion caps), shall not exceed 115 dB when tested per 8.20.2.5. Sounds produced by explosive action of push or pull toys shall conform to the L_{Cpeak} requirement in 4.5.1.7.

4.5.1.7 *Toys Using Explosive Action*—The C-weighted peak sound pressure level, L_{Cpeak} , produced by a toy using explosive action (for example, percussion caps), shall not exceed 125 dB when tested per 8.20.2.6.

4.6 *Small Objects*—These requirements are intended to minimize the hazards from choking, ingestion, or inhalation to children under 36 months of age created by small objects.

4.6.1 Toys that are intended for children under 36 months of age are subject to the requirements of 16 CFR 1501. Criteria for determining which toys are subject to these requirements are provided, in part, in 16 CFR 1500.50 and 1501 and also in Annex A1 of this specification. The requirements of 16 CFR 1501 state, in part, that no toy (including removable, liberated components, or fragments of toys) shall be small enough without being compressed to fit entirely within a cylinder of the specified dimensions as shown in Fig. 3. For the purposes of this specification, fragments of toys include, but are not limited to, pieces of flash, slivers of plastics, pieces of foam, or fine bits or shavings. Pieces of paper, fabric, yarn, fuzz, elastic, and string are excluded from this requirement.

4.6.1.1 The requirements are applicable before and after use and abuse testing in accordance with Section 8 to determine the accessibility of small objects such as small toys or components of toys including eyes, squeakers, or knobs, or pieces that break off or are removed from toys.

4.6.1.2 The following articles are exempt from the requirements: balloons; books and other paper articles; writing materials (crayons, chalk, pencils, and pens); phonograph records and compact discs (CDs); modeling clay and similar products; and fingerpaints, watercolors, and other paint sets. A listing of exempt articles is provided in 16 CFR 1501.3.

4.6.1.3 Toys that are intended to be assembled by an adult and contain potentially hazardous small objects in the unassembled state shall be labeled in accordance with 5.8.

4.6.2 *Mouth-actuated Toys:*

4.6.2.1 This requirement relates to toys, such as noisemakers, that are intended to be actuated by blowing or sucking. Mouth-actuated toys that contain loose objects, such

as spheres in a whistle, or inserts, such as reeds in a noisemaker, shall not release an object that will fit within the small parts test cylinder, as shown in Fig. 3, when air is alternatively blown and sucked rapidly through the mouthpiece, when tested in accordance with 8.13.1. The procedure of 8.13.1 shall also be applied to the outlet if the air outlet is capable of being inserted into or covered by the mouth.

4.6.2.2 Projectile toys in which the projectile is launched by the user blowing into the discharge mechanism.

(1) Mouth-actuated discharge mechanisms shall include a permanently-installed means to prevent passage of the projectile backwards through the mouth end of the launcher when tested in accordance with 8.13.2. This mechanism shall not be user-removable and shall not detach during testing per applicable sections of 8.7.1, 8.8, 8.9, and 8.10. If such means to prevent passage of the projectile is integral with the mouthpiece, the mouthpiece shall not be user-removable, and shall not detach during testing per applicable sections of 8.7.1, 8.8, 8.9, and 8.10. If the toy includes user-removable mouthpieces or projectiles of different designs, or both, each design or combination, or both, shall be tested separately.

(2) Mouthpieces intended to be user-removable shall not fit entirely within the small parts test cylinder, as shown in Fig. 3. If a permanently-attached mouthpiece detaches from the discharge mechanism when subjected to applicable sections of 8.7.1, 8.8, 8.9, and 8.10, it shall not fit entirely within the small parts test cylinder, as shown in Fig. 3.

NOTE 14—The requirements of 4.6.2.2 apply to all mouth actuated projectile launchers regardless of the intended age group of the toy.

4.6.2.3 Small objects contained in an inflatable toy shall not be liberated during inflation or deflation.

4.6.3 Toys and games that are intended for use by children who are at least three years old (36 months) but less than six years of age (72 months) are subject to the requirements of 16 CFR 1500.19. With the exception of products such as paper punch-out games and similar items, any toy or game that is intended for use by children who are at least three years old (36 months) but less than six years of age (72 months) and includes a small part is subject to the labeling requirements in accordance with 5.11.2.

4.7 *Accessible Edges*—Toys shall not have accessible, potentially hazardous sharp edges. Toys that are intended to be assembled by an adult, and may contain unprotected potentially hazardous sharp edges in the unassembled state, shall be labeled in accordance with 5.8.

4.7.1 Potentially hazardous sharp metal and glass edges are defined in 16 CFR 1500.49. Toys intended for use by children under 8 years of age are subject to this requirement before or after use and abuse testing, or both, as specified in 8.5 – 8.10. An illustration of a sharp edge tester is shown in Fig. 8.

4.7.2 Toys containing potentially hazardous edges that are a necessary part of the function of a toy shall carry cautionary labeling as specified in 5.10 if the toy is intended for use by children from 48 months to 96 months. Toys intended for children aged less than 48 months shall not have accessible hazardous functional sharp edges.