



Designation: **C1243–93 (Reapproved 2015)^{ε2} C1243 – 23**

Standard Test Method for Relative Resistance to Deep Abrasive Wear of Unglazed Ceramic Tile by Rotating Disc¹

This standard is issued under the fixed designation C1243; the number immediately following the designation indicates the year of original adoption or, in the case of revision, the year of last revision. A number in parentheses indicates the year of last reapproval. A superscript epsilon (ϵ) indicates an editorial change since the last revision or reapproval.

^{ε1} NOTE—Corrected Eq 1 editorially in Nov. 2019.

1. Scope

1.1 This test method covers the deep abrasive wear by measuring the loss of volume resulting from abrasion of unglazed ceramic tile under given conditions by means of a rotating disc and the use of abrasive material.

1.2 The values stated in SI units are to be regarded as standard. No other units of measurement are included in this standard.

1.3 *This standard does not purport to address all of the safety concerns, if any, associated with its use. It is the responsibility of the user of this standard to establish appropriate safety, health, and environmental practices and determine the applicability of regulatory limitations prior to use.*

1.4 *This international standard was developed in accordance with internationally recognized principles on standardization established in the Decision on Principles for the Development of International Standards, Guides and Recommendations issued by the World Trade Organization Technical Barriers to Trade (TBT) Committee.*

2. Referenced Documents

- 2.1 *ASTM Standards:*²
- [C242 Terminology of Ceramic Whitewares and Related Products](#)
 - [C448 Test Methods for Abrasion Resistance of Porcelain Enamels](#)
 - [C501 Test Method for Relative Resistance to Wear of Unglazed Ceramic Tile by the Taber Abraser](#)
 - [C1027 Test Method for Determining Visible Abrasion Resistance of Glazed Ceramic Tile](#)

3. Terminology

3.1 Definitions:

3.1.1 For definitions of terms used in this test method, see Terminology [C242](#).

4. Significance and Use

4.1 This test method provides the means to measure the potential resistance to wear of unglazed ceramic tile intended for floor

¹ This test method is under the jurisdiction of ASTM Committee C21 on Ceramic Whitewares and Related Products and is the direct responsibility of Subcommittee C21.06 on Ceramic Tile.

Current edition approved Dec. 15, 2015; Oct. 1, 2023. Published December 2015; October 2023. Originally approved in 1993. Last previous edition approved in 2015 as C1243 – 93 (2015); (2015)^{ε2}. DOI: 10.1520/C1243-93R15E02; 10.1520/C1243-23.

² For referenced ASTM standards, visit the ASTM website, www.astm.org, or contact ASTM Customer Service at service@astm.org. For *Annual Book of ASTM Standards* volume information, refer to the standard's Document Summary page on the ASTM website.

coverings. This test method does not consider physical appearance but is intended to measure durability. See Test Method C1027 for the determination of visible abrasion resistance of glazed ceramic tile.

4.1.1 See Test Method C501 for an alternative method to determine deep abrasion.

5. Apparatus³

5.1 Abrasion apparatus (see Fig. 1) consisting essentially of a rotating disc, a storage hopper with a dispensing device for the abrasive material, a test specimen support, and a counterweight. The disc is made of Fe 360A steel (ISO 630-1980) with a diameter of 200 ± 0.2 mm and thickness at the edge of 10 ± 0.1 mm, and with a rate of revolution of 75 r/min. The pressure with which test specimens are held against the steel disc is determined by calibrating the apparatus against float glass (bathside)-fused silica. The pressure is adjusted such that, after 150 revolutions, a chord of 24 ± 0.5 mm is produced.

Note 1—For the specification of float glass, see Test Method C448, Table A1.4.

5.1.1 When the disc diameter has worn to 199 mm, the steel disc shall be replaced.

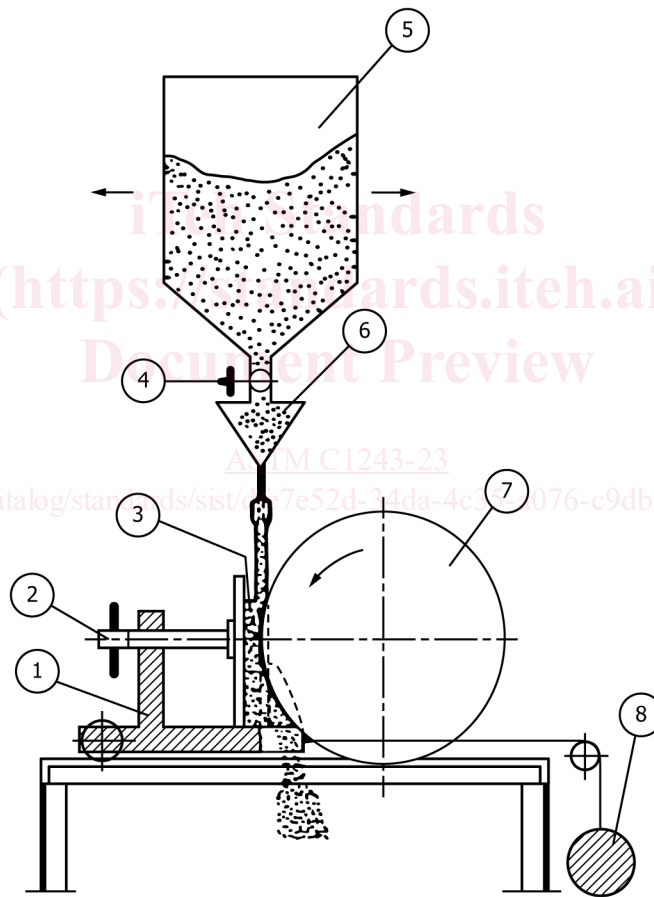

1. Test specimen clamp
2. Fixing screw
3. Test specimen
4. Valve
5. Storage hopper for abrasive material
6. Even-flow funnel
7. Steel disc
8. Counterweight

FIG. 1 Abrasion Apparatus

³ The sole source of supply of the apparatus known to the committee at this time is Gabrielli S.R.L., Box 218, 50019 Sesto Fiorentino, Florence, Italy, Fax: 55-42-15-654.. If you are aware of alternative suppliers, please provide this information to ASTM International Headquarters. Your comments will receive careful consideration at a meeting of the responsible technical committee,¹ which you may attend.