



Standard Test Method for Critical Radiant Flux of Exposed Attic Floor Insulation Using a Radiant Heat Energy Source¹

This standard is issued under the fixed designation E970; the number immediately following the designation indicates the year of original adoption or, in the case of revision, the year of last revision. A number in parentheses indicates the year of last reapproval. A superscript epsilon (ϵ) indicates an editorial change since the last revision or reapproval.

1. Scope

1.1 This fire-test-response standard describes a procedure for measuring the critical radiant flux of exposed attic floor insulation subjected to a flaming ignition source in a graded radiant heat energy environment in a test chamber. The specimen is any attic floor insulation. This test method is not applicable to those insulations that melt or shrink away when exposed to the radiant heat energy environment or the pilot burner.

1.2 This fire-test-response standard measures the critical radiant flux at the point at which the flame advances the farthest. It provides a basis for estimating one aspect of fire exposure behavior for exposed attic floor insulation. The imposed radiant flux simulates the thermal radiation levels likely to impinge on the floors of attics whose upper surfaces are heated by the sun through the roof or by flames from an incidental fire in the attic. This fire-test-response standard was developed to simulate an important fire exposure component of fires that develop in attics, but is not intended for use in estimating flame spread behavior of insulation installed other than on the attic floor.

1.3 The values stated in SI units are to be regarded as standard. The values given in parentheses are for information only.

1.4 The text of this standard references notes and footnotes that provide explanatory information. These notes and footnotes, excluding those in tables and figures, shall not be considered as requirements of this standard.

1.5 *This standard is used to measure and describe the response of materials, products, or assemblies to heat and flame under controlled conditions, but does not by itself incorporate all factors required for fire hazard or fire risk assessment of the materials, products, or assemblies under actual fire conditions.*

¹ This test method is under the jurisdiction of ASTM Committee E05 on Fire Standards and is the direct responsibility of Subcommittee E05.22 on Surface Burning.

Current edition approved Oct. 1, 2023. Published October 2023. Originally approved in 1983. Last previous edition approved in 2017 as E970–17^{ε1}. DOI: 10.1520/E0970-23.

1.6 *This standard does not purport to address all of the safety concerns, if any, associated with its use. It is the responsibility of the user of this standard to establish appropriate safety, health, and environmental practices and determine the applicability of regulatory limitations prior to use.*

1.7 The text of this standard references notes and footnotes which provide explanatory material. These notes and footnotes (excluding those in tables and figures) shall not be considered as requirements of the standard.

1.8 *This international standard was developed in accordance with internationally recognized principles on standardization established in the Decision on Principles for the Development of International Standards, Guides and Recommendations issued by the World Trade Organization Technical Barriers to Trade (TBT) Committee.*

2. Referenced Documents

2.1 ASTM Standards:²

- C167 Test Methods for Thickness and Density of Blanket or Batt Thermal Insulations
- C665 Specification for Mineral-Fiber Blanket Thermal Insulation for Light Frame Construction and Manufactured Housing
- C739 Specification for Cellulosic Fiber Loose-Fill Thermal Insulation
- C764 Specification for Mineral Fiber Loose-Fill Thermal Insulation
- E84 Test Method for Surface Burning Characteristics of Building Materials
- E122 Practice for Calculating Sample Size to Estimate, With Specified Precision, the Average for a Characteristic of a Lot or Process
- E176 Terminology of Fire Standards
- E177 Practice for Use of the Terms Precision and Bias in ASTM Test Methods
- E631 Terminology of Building Constructions
- E648 Test Method for Critical Radiant Flux of Floor-Covering Systems Using a Radiant Heat Energy Source

² For referenced ASTM standards, visit the ASTM website, www.astm.org, or contact ASTM Customer Service at service@astm.org. For *Annual Book of ASTM Standards* volume information, refer to the standard's Document Summary page on the ASTM website.

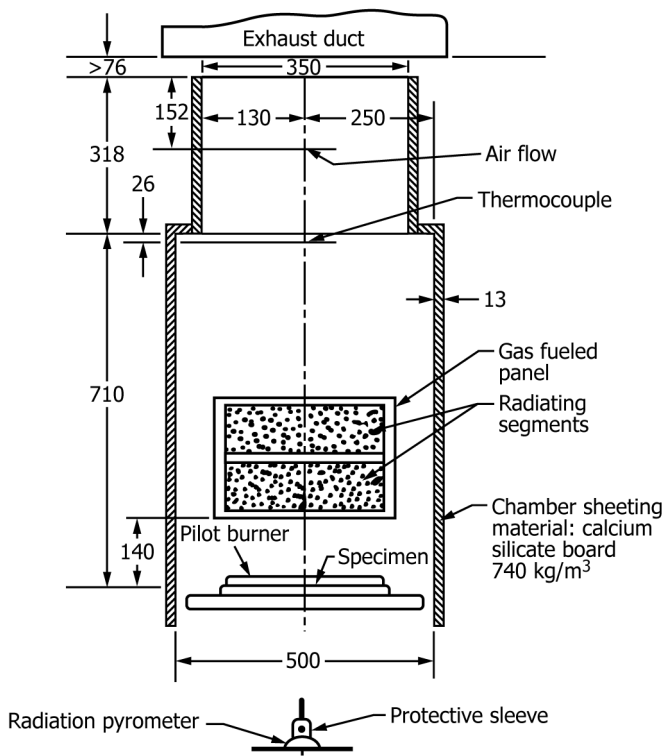

NOTE 1—All dimensions in millimetres. 1 in. = 25.4 mm.

FIG. 2 Flooring Radiant Panel Tester Schematic Low Flux End, Elevation

moved out for mounting or removal of test specimens. At the low flux end of the chamber on the 500 mm side, a draft-tight fire-resistant window is permitted for additional observations.

6.1.2 The bottom of the test chamber shall consist of a sliding steel platform which has provisions for rigidly securing the test specimen holder in fixed and level position. The free, or air access, area around the platform shall be in the range from 0.2580 m² to 0.3225 m² (400 in.² to 500 in.²).

6.1.3 When the flame front advance is to be measured, a metal scale marked with 10 mm intervals shall be installed on the back of the platform or on the back wall of the chamber.

6.1.4 The top of the chamber shall have an exhaust stack with interior dimensions of 102 mm ± 3 mm (4 in. ± 0.13 in.) wide by 380 mm ± 3 mm (15.00 in. ± 0.13 in.) deep by 318 mm ± 3 mm (12.50 in. ± 0.13 in.) high at the opposite end of the chamber from the radiant energy source.

6.2 *Radiant Heat Energy Source*, a panel of porous material mounted in a cast iron or steel frame, with a radiation surface of 305 mm by 457 mm (12 in. by 18 in.). It shall be capable of operating at temperatures up to 816 °C (1500 °F). The panel fuel system shall consist of a venturi-type aspirator for mixing gas⁴ and air at approximately atmospheric pressure, a clean dry air supply capable of providing 28.3 m³/h (1000 f³/h) at standard temperature and pressure at 76 mm (3.0 in.) of water,

⁴ Gas used in this test method shall be either commercial grade propane having a heating value of approximately 83.1 MJ/m³ (2500 Btu/ft³), or natural gas, or commercial grade methane having a minimum purity of 96 %.

and suitable instrumentation for monitoring and controlling the flow of fuel to the panel.

6.2.1 The radiant heat energy panel is mounted in the chamber at 30° ± 5° to the horizontal specimen plane. The radiant energy panel angle shall be adjusted to obtain the flux profile within the limits specified in accordance with 10.6. The horizontal distance from the 0 mark on the specimen fixture to the bottom edge (projected) of the radiating surface of the panel is 89 mm ± 3 mm (3.5 in. ± 0.13 in.). The panel-to-specimen vertical distance is 140 mm ± 3 mm (5.5 in. ± 0.13 in.) (Fig. 1).

6.2.2 *Radiation Pyrometer* for standardizing the thermal output of the panel, suitable for viewing a circular area 254 mm (10 in.) in diameter at a range of about 1.37 m (54 in.). It shall be calibrated over the 460 °C to 510 °C (860 °F to 950 °F) operating blackbody temperature range in accordance with the procedure described in Annex A1.

6.2.3 *Voltmeter*, high-impedance or potentiometric, with a suitable millivolt range shall be used to monitor the output of the radiation pyrometer described in 6.2.2.

6.3 *Dummy Specimen Holder* (Fig. 3 and Fig. 4), constructed from heat-resistant stainless steel (UNS N08330 (AISI Type 330) or equivalent) having a thickness of 1.98 mm (0.078 in.) and an overall dimension of 1140 mm by 320 mm (45 in. by 12¾ in.) with a specimen opening of 200 mm by 1000 mm (7.9 in. by 39.4 in.). Six slots shall be cut in the flange on either side of the holder to reduce warping. The holder shall be fastened to the platform with two stud bolts at each end.

6.4 *Dummy Specimen*, used in the flux profile determination, made of 19 mm (¾-in.) inorganic 740 kg/m³ (46-lb/ft³) nominal density calcium silicate board (Fig. 3 and

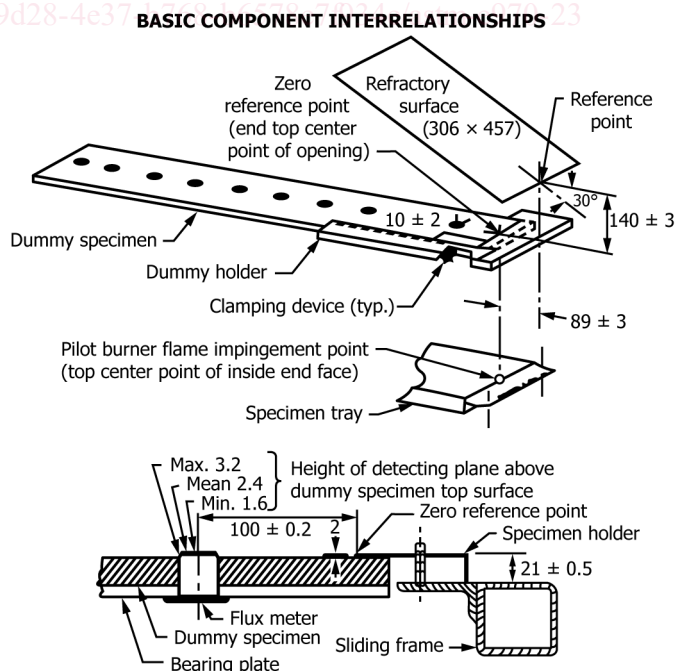

NOTE 1—All dimensions in millimetres. 1 in. = 25.4 mm.

FIG. 3 Zero Reference Point Related to Detecting Plane

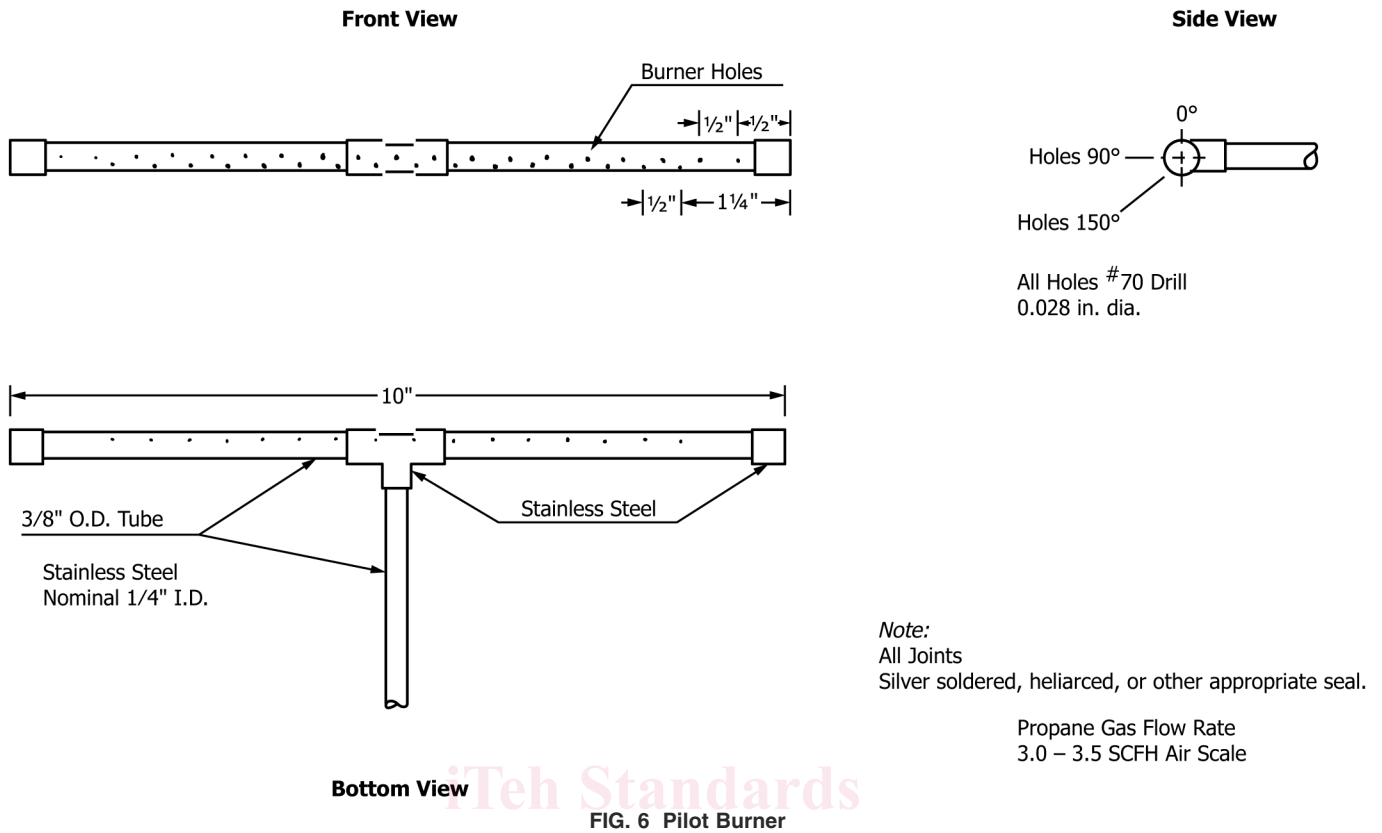

FIG. 6 Pilot Burner

position, the pilot flame will extend from approximately 63.5 mm (2.5 in.) at the ends to approximately 127 mm (5 in.) at the center.

6.7.2 The holes in the pilot burner shall be kept clean. One means for opening the holes in the pilot burner is to use nickel-chromium or stainless steel wire that has a diameter of 0.5 mm (0.020 in.). Surface contaminants shall be removed from the burner. One means for removing contaminants is the use of a soft wire brush.

6.7.3 The pilot burner is positioned no more than 5° from the horizontal so that the flame generated will impinge on, and reach out over the specimen from the zero distance point (see Fig. 1 and Fig. 2). The burner must have the capability of being moved at least 50 mm (2 in.) away from the specimen when not in use.

6.8 *Thermocouples*—A 3.2 mm (1/8-in.) stainless steel sheathed grounded junction Chromel-Alumel thermocouple (6.8.1) shall be located in the radiant panel test chamber (Fig. 1 and Fig. 2). The chamber thermocouple is located in the longitudinal central vertical plane of the chamber 25 mm (1 in.) down from the top and 102 mm (4 in.) back from the inside of the exhaust stack.

6.8.1 The thermocouple shall be kept clean to ensure accuracy of readout.

6.8.2 An indicating potentiometer with a range from 100 °C to 500 °C (212 °F to 932 °F) shall be used to determine the chamber temperature prior to a test.

6.9 *Exhaust Duct*, with a capacity of 28.3 m³/min to 85 m³/min (1000 ft³/min to 3000 ft³/min) at standard tempera-

ture and pressure decoupled from the chamber stack by at least 76 mm (3 in.) on all sides and with an effective area of the canopy slightly larger than plane area of the chamber with the specimen platform in the OUT position, is used to remove combustion products from the chamber. With the panel turned on and the dummy specimen in place, the air flow through the stack shall be 76.2 m/min ± 15.2 m/min (250 ft/min. ± 50 ft/min.) when measured with a calibrated hot-wire anemometer. The reading is taken about 30 s after insertion of the probe into the center of the stack opening at a distance of 152 mm (6 in.) down from the top of the stack opening (Fig. 1 and Fig. 2).

6.10 A timing device with a minimum resolution of 0.10 min shall be used to measure preheat, pilot contact, time of maximum flame travel, and when all flaming goes out.

7. Hazards

7.1 Suitable safeguards following sound engineering practices shall be installed in the panel fuel supply to guard against a gas-air explosion in the test chamber. Consideration shall be given, but not limited to the following : (1) a gas feed cutoff activated when the air supply fails, (2) a fire sensor directed at the panel surface that stops fuel flow when the panel flame goes out, and (3) a commercial gas water heater or gas-fired furnace pilot burner control thermostatic shut-off that is activated when the gas supply fails or other suitable and approved device. Manual reset is a requirement of any safeguard system used.

7.2 In view of the potential hazard from products of combustion, the exhaust system must be so designed and

operated that the laboratory environment is protected from smoke and gas. The operator shall be instructed to minimize his exposure to combustion products by following sound safety practice; for example, ensure that the exhaust system is working properly, wear appropriate clothing including gloves, etc.

8. Sampling

8.1 The samples selected for testing shall be representative of the product.

8.2 Standard ASTM sampling practice shall be followed where applicable; see Practice E122 for choice of sample size to estimate the average quality of a lot or process.

9. Test Specimens

9.1 The test specimen shall be attic floor insulation sized to provide for adequate filling of the specimen tray (see Fig. 5).

9.2 A minimum of three specimens per sample shall be tested.

9.3 The insulation specimen to be used for the test shall simulate actual installation practice.

9.4 The insulation specimen shall be representative of the manufacturer's recommended design density for loose-fill insulation, or the manufactured density for board and batt type insulation.

9.5 The following are specific instructions for some individual types of materials. The materials discussed under 9.5.1 through 9.5.4 represent some materials typically used with this test method. Sections 9.5.1 through 9.5.4 do not exclude other materials, which shall also be permitted to be tested in accordance with this test method.

9.5.1 Cellulosic Fiber Loose-Fill

9.5.1.1 The test shall be conducted at the design density per Specification C739.

9.5.1.2 If the design density is not provided by product label, determine the product design density in accordance with Section 8 procedures of Specification C739.

9.5.1.3 Determine the weight of insulation required to fill the specimen tray to achieve the design density determined above.

9.5.1.4 Specimen trays shall be prepared for testing by one of the following two methods described in 9.5.3.

9.5.2 Mineral Fiber Loose-Fill

9.5.2.1 The test shall be conducted at the design density as defined in Specification C764.

9.5.2.2 If no design density is provided by the product label then the test shall be conducted at the as-blown density. The report shall indicate that the as-blown density was used for the test.

9.5.2.3 Determine the weight of insulation required to fill the specimen tray to achieve the design density determined above.

9.5.2.4 Specimen trays shall be prepared for testing by one of the following two methods described in 9.5.3.

9.5.3 Preparing Loose-Fill Specimen Trays

9.5.3.1 Method A – Hand Loading

(1) Blow the material through a commercial blower using a minimum length of 30.5 m (100 ft) length of hose, with a hose diameter as recommended per manufacturer installation requirements. Blow into a sample receiver while holding the hose horizontally at a height of 4 ft.

(2) Load the specimen tray by hand with the amount of insulation measured by weight that corresponds to the density of insulation. Gently shake the specimen to settle the insulation while loading. The top of the insulation is to be level with the top of the tray.

(3) Be careful not to compact the insulation.

9.5.3.2 Method B—Blowing the material into the specimen trays.

(1) Blow the material through a commercial blower using a minimum length of 30.5 m (100 ft) length of hose, with a hose diameter as recommended per manufacturer installation requirements. While holding the hose horizontally at a height of 4 ft, blow the test sample into the test specimen trays.

(2) Gently shake specimen, removing excess and over-blown insulation. The specimen shall then be gently screeded with a metal straight edge in one direction so that the specimen is level across the top of the tray. Take care not to compact the insulation.

(3) As an alternative to screeding, the specimen tray may be gently dropped onto a hard level surface until the specimen is level with the sides of the specimen tray. Holding the specimen tray at a height of 1 in., drop the tray. Repeat as needed.

(4) Surface irregularities shall not exceed 4.8 mm ($\frac{3}{16}$ in.). Additional material may be added to fill any voids or valleys around the periphery of the specimen tray.

(5) Weigh each of the specimen trays to validate that the material is at design density.

9.5.4 Insulation Batts or Boards

9.5.4.1 Cut the batts or boards to a thickness of 50 mm (2 in.) and cut to fit into the specimen tray.

9.5.4.2 The test density for the batt or board specimens shall be determined in accordance with Section 8 of Test Method C167 prior to the test.

10. Radiant Heat Energy Flux Profile Standardization

10.1 In a continuing program of tests, the flux profile shall be determined not less than once a week. Where the time interval between tests is greater than one week, the flux profile shall be determined at the start of the test series.

10.2 Mount the dummy specimen in the mounting frame, and attach the assembly to the sliding platform.

10.3 With the sliding platform out of the chamber, turn on the exhaust, and ignite the radiant panel. Allow the unit to heat for 1.5 h. The pilot burner is off during this determination. Adjust the fuel mixture to give an air-rich flame. Make fuel flow settings to bring the panel blackbody temperature to $485\text{ }^{\circ}\text{C} \pm 25\text{ }^{\circ}\text{C}$ ($839\text{ }^{\circ}\text{F} \pm 45\text{ }^{\circ}\text{F}$) and record the chamber temperature. After the panel blackbody temperature has stabilized, move the specimen platform into the chamber and close the door.

10.4 Allow 0.5 h for the closed chamber to equilibrate.