



Designation: ~~E970 – 17^{ε1}~~ E970 – 23

An American National Standard

Standard Test Method for Critical Radiant Flux of Exposed Attic Floor Insulation Using a Radiant Heat Energy Source¹

This standard is issued under the fixed designation E970; the number immediately following the designation indicates the year of original adoption or, in the case of revision, the year of last revision. A number in parentheses indicates the year of last reapproval. A superscript epsilon (ϵ) indicates an editorial change since the last revision or reapproval.

^{ε1} NOTE—Fig. 5 and SI units were updated editorially in July 2022.

1. Scope*Scope

1.1 This fire-test-response standard describes a procedure for measuring the critical radiant flux of exposed attic floor insulation subjected to a flaming ignition source in a graded radiant heat energy environment in a test chamber. The specimen is any attic floor insulation. This test method is not applicable to those insulations that melt or shrink away when exposed to the radiant heat energy environment or the pilot burner.

1.2 This fire-test-response standard measures the critical radiant flux at the point at which the flame advances the farthest. It provides a basis for estimating one aspect of fire exposure behavior for exposed attic floor insulation. The imposed radiant flux simulates the thermal radiation levels likely to impinge on the floors of attics whose upper surfaces are heated by the sun through the roof or by flames from an incidental fire in the attic. This fire-test-response standard was developed to simulate an important fire exposure component of fires that develop in attics, but is not intended for use in estimating flame spread behavior of insulation installed other than on the attic floor.

1.3 The values stated in SI units are to be regarded as standard. The values given in parentheses are for information only.

<https://standards.iteh.ai/catalog/standards/sist/e2c56a78-9d28-4e37-b768-b6578e7f934e/astm-e970-23>

1.4 The text of this standard references notes and footnotes that provide explanatory information. These notes and footnotes, excluding those in tables and figures, shall not be considered as requirements of this standard.

1.5 *This standard is used to measure and describe the response of materials, products, or assemblies to heat and flame under controlled conditions, but does not by itself incorporate all factors required for fire hazard or fire risk assessment of the materials, products, or assemblies under actual fire conditions.*

1.6 *This standard does not purport to address all of the safety concerns, if any, associated with its use. It is the responsibility of the user of this standard to establish appropriate ~~safety and health~~ safety, health, and environmental practices and determine the applicability of regulatory limitations prior to use.*

1.7 The text of this standard references notes and footnotes which provide explanatory material. These notes and footnotes (excluding those in tables and figures) shall not be considered as requirements of the standard.

1.8 *This international standard was developed in accordance with internationally recognized principles on standardization established in the Decision on Principles for the Development of International Standards, Guides and Recommendations issued by the World Trade Organization Technical Barriers to Trade (TBT) Committee.*

¹ This test method is under the jurisdiction of ASTM Committee E05 on Fire Standards and is the direct responsibility of Subcommittee E05.22 on Surface Burning. Current edition approved July 1, 2017/Oct. 1, 2023. Published July 2017/October 2023. Originally approved in 1983. Last previous edition approved in 2014/2017 as E970 – 14, – 17^{ε1}. DOI: 10.1520/E0970-17E01.10.1520/E0970-23.

*A Summary of Changes section appears at the end of this standard

2. Referenced Documents

2.1 ASTM Standards:²

- C167 Test Methods for Thickness and Density of Blanket or Batt Thermal Insulations
- C665 Specification for Mineral-Fiber Blanket Thermal Insulation for Light Frame Construction and Manufactured Housing
- C739 Specification for Cellulosic Fiber Loose-Fill Thermal Insulation
- C764 Specification for Mineral Fiber Loose-Fill Thermal Insulation
- E84 Test Method for Surface Burning Characteristics of Building Materials
- E122 Practice for Calculating Sample Size to Estimate, With Specified Precision, the Average for a Characteristic of a Lot or Process
- E176 Terminology of Fire Standards
- E177 Practice for Use of the Terms Precision and Bias in ASTM Test Methods
- E631 Terminology of Building Constructions
- E648 Test Method for Critical Radiant Flux of Floor-Covering Systems Using a Radiant Heat Energy Source
- E691 Practice for Conducting an Interlaboratory Study to Determine the Precision of a Test Method
- E2653 Practice for Conducting an Interlaboratory Study to Determine Precision Estimates for a Test Method with Fewer Than Six Participating Laboratories

2.2 Federal Specifications:

- HH-I-515 Insulation Thermal (Loose Fill for Pneumatic or Poured Application), Cellulosic or Wood Fiber³
- HH-I-521, Insulation Blankets, Thermal (Mineral Fiber, for Ambient Temperature)³
- HH-I-1030 Insulation, Thermal (Mineral Fiber, for Pneumatic or Poured Application)³

3. Terminology

3.1 For definitions of terms used in this test method and associated with fire issues refer to the terminology contained in Terminology E176.

3.2 Definitions:

3.2.1 *attic, n*—an accessible enclosed space in a building immediately below the roof and wholly or partly within the roof framing.

3.2.2 See Terminology E631 for additional definitions of terms used in this test method.

3.3 Definitions of Terms Specific to This Standard:

3.3.1 *critical radiant flux, n*—the level of incident radiant heat energy on the attic floor insulation system at the most distant flame-out point. It is reported as W/cm² (or Btu/ft²·s).

3.3.2 *radiant flux profile, n*—the graph relating incident radiant heat energy on the specimen plane to distance from the point of initiation of flaming ignition, that is, 0 mm.

3.3.3 *total flux metre, n*—the instrument used to measure the level of radiant heat energy incident on the specimen plane at any point.

4. Summary of Test Method

4.1 A horizontally mounted insulation specimen is exposed to the heat from an air-gas radiant heat energy panel located above and inclined at $30 \pm 5^\circ$ to the specimen. After a short preheat, the hottest end of the specimen is ignited with a small calibrated flame. The distance to the farthest advance of flaming is measured, converted to kilowatts per square meter from a previously prepared radiant flux profile graph, and reported as the critical radiant flux.

5. Significance and Use

5.1 This fire-test-response standard is designed to provide a basis for estimating one aspect of the fire exposure behavior to

² For referenced ASTM standards, visit the ASTM website, www.astm.org, or contact ASTM Customer Service at service@astm.org. For *Annual Book of ASTM Standards* volume information, refer to the standard's Document Summary page on the ASTM website.

³ Available from Standardization Documents Order Desk, DODSSP, Bldg. 4, Section D, 700 Robbins Ave., Philadelphia, PA 19111-5098, http://www.dodssp.daps.mil.

exposed insulation installed on the floors of building attics. The test environment is intended to simulate conditions that have been observed and defined in full-scale attic experiments.

5.2 The test is intended to be suitable for regulatory statutes, specification acceptance, design purposes, or development and research.

5.3 The fundamental assumption inherent in the test is that critical radiant flux is one measure of the surface burning characteristics of exposed insulation on floors or between joists of attics.

5.4 The test is applicable to attic floor insulation specimens that follow or simulate accepted installation practice.

5.5 In this procedure, the specimens are subjected to one or more specific sets of laboratory fire test exposure conditions. If different test conditions are substituted or the anticipated end-use conditions are changed, caution should be used to predict changes in the performance characteristics measured by or from this test. Therefore, the results are strictly valid only for the fire test exposure conditions described in this procedure.

5.5.1 If the test results obtained by this test method are to be considered in the total assessment of fire hazard in a building structure, then all pertinent established criteria for fire hazard assessment developed by Committee E-5 must be included in the consideration.

6. Apparatus

6.1 The apparatus shall be as shown in Fig. 1, located in a draft-protected laboratory that maintains a temperature from 10.0 °C to 26.7 °C (50 °F to 80 °F) and a relative humidity from 30% to 70%:

6.1.1 The radiant panel test chamber (Fig. 1 and Fig. 2) shall consist of an enclosure 1400 mm (55 in.) long by 500 mm (19½ in.) deep by 710 mm (28 in.) above the test specimen. The sides, ends, and top shall be of 13 mm (½-in.) calcium silicate, 740 kg/m³ (46-lb/ft³) nominal density, insulating material with a thermal conductivity at 177 °C (350 °F) of 0.128 W/(m·K) (0.89 Btu · in./(h·ft²·°F)). One side shall be provided with an approximately 100 mm by 1100 mm (4 in. by 44 in.) draft-tight fire-resistant glass window so that the entire length of the test specimen is visible from outside the fire test chamber. On the same side and below the observation window is a door which, when open, allows the specimen platform to be moved out for mounting or removal of test specimens. At the low flux end of the chamber on the 500 mm side, a draft-tight fire-resistant window is permitted for additional observations.

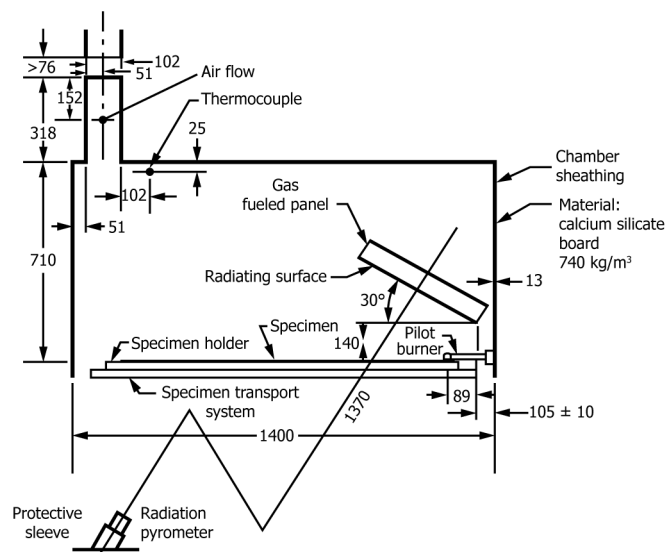

NOTE 1—All dimensions in millimetres. 1 in. = 25.4 mm.

FIG. 1 Flooring Radiant Tester Schematic, Side Elevation

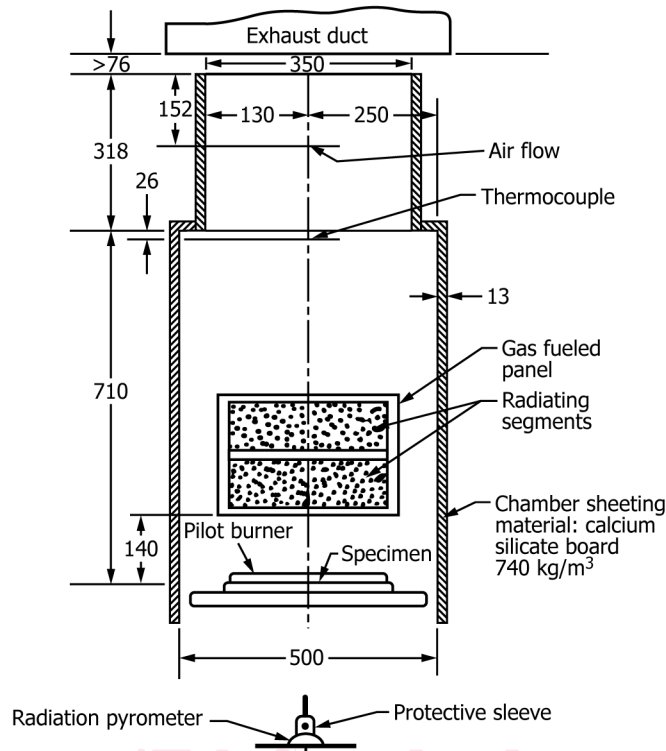

NOTE 1—All dimensions in millimetres. 1 in. = 25.4 mm.

FIG. 2 Flooring Radiant Panel Tester Schematic Low Flux End, Elevation

(<https://standards.iteh.ai>)

Document Preview

6.1.2 The bottom of the test chamber shall consist of a sliding steel platform which has provisions for rigidly securing the test specimen holder in fixed and level position. The free, or air access, area around the platform shall be in the range from 0.2580 m² to 0.3225 m² (400 in.² to 500 in.²).

ASTM E970-23

6.1.3 When the flame front advance is to be measured, a metal scale marked with 10 mm intervals shall be installed on the back of the platform or on the back wall of the chamber.

6.1.4 The top of the chamber shall have an exhaust stack with interior dimensions of 102 mm ± 3 mm (4 in. ± 0.13 in.) wide by 380 mm ± 3 mm (15.00 in. ± 0.13 in.) deep by 318 mm ± 3 mm (12.50 in. ± 0.13 in.) high at the opposite end of the chamber from the radiant energy source.

6.2 *Radiant Heat Energy Source*, a panel of porous material mounted in a cast iron or steel frame, with a radiation surface of 305 mm by 457 mm (12 in. by 18 in.). It shall be capable of operating at temperatures up to 816 °C (1500 °F). The panel fuel system shall consist of a venturi-type aspirator for mixing gas⁴ and air at approximately atmospheric pressure, a clean dry air supply capable of providing 28.3 m³/h (1000 f³/h) at standard temperature and pressure at 76 mm (3.0 in.) of water, and suitable instrumentation for monitoring and controlling the flow of fuel to the panel.

6.2.1 The radiant heat energy panel is mounted in the chamber at 30° ± 5° to the horizontal specimen plane. The radiant energy panel angle shall be adjusted to obtain the flux profile within the limits specified in accordance with 10.6. The horizontal distance from the 0 mark on the specimen fixture to the bottom edge (projected) of the radiating surface of the panel is 89 mm ± 3 mm (3.5 in. ± 0.13 in.). The panel-to-specimen vertical distance is 140 mm ± 3 mm (5.5 in. ± 0.13 in.) (5.5 in. ± 0.13 in.) (Fig. 1).

6.2.2 *Radiation Pyrometer* for standardizing the thermal output of the panel, suitable for viewing a circular area 254 mm (10 in.) in diameter at a range of about 1.37 m (54 in.). It shall be calibrated over the 460 °C to 510 °C (860 °F to 950 °F) operating blackbody temperature range in accordance with the procedure described in Annex A1.

⁴ Gas used in this test method shall be either commercial grade propane having a heating value of approximately 83.1 MJ/m³ (2500 Btu/ft³), or natural gas, or commercial grade methane having a minimum purity of 96 %.

6.2.3 *Voltmeter*, high-impedance or potentiometric, with a suitable millivolt range shall be used to monitor the output of the radiation pyrometer described in 6.2.2.

6.3 *Dummy Specimen Holder* (Fig. 3 and Fig. 4), constructed from heat-resistant stainless steel (UNS N08330 (AISI Type 330) or equivalent) having a thickness of 1.98 mm (0.078 in.) (0.078 in.) and an overall dimension of 401.140 mm by 320 mm (45 in. by 12 3/4 in.) with a specimen opening of 200 mm by 1000 mm (7.9 in. by 39.4 in.). Six slots shall be cut in the flange on either side of the holder to reduce warping. The holder shall be fastened to the platform with two stud bolts at each end.

6.4 *Dummy Specimen*, used in the flux profile determination, made of 19 mm (3/4-in.) inorganic 740 kg/m³ (46-lb/ft³) nominal density calcium silicate board (Fig. 3 and Fig. 4). It is 250 mm (10 in.) wide by 1070 mm (42 in.) long with 27 mm (1 1/16-in.) diameter holes centered on and along the centerline at the 100, 200, 300, . . . , 900, and 980 mm locations measured from the maximum flux end of the specimen.

6.4.1 To provide proper and consistent seating of the flux meter in the hole openings, a stainless steel or galvanized steel bearing plate (Fig. 3 and Fig. 4) shall be mounted and firmly secured to the underside of the calcium silicate board with holes corresponding to those specified above. The bearing plate shall run the length of the dummy specimen board and have a width of 76 mm (3.0 in.). The thickness of the bearing plate shall be set in order to maintain the flux meter height specified in 10.5. The maximum thickness of the bearing plate shall not exceed 3 mm (1/8 in.).

6.5 *Total Heat Flux Transducer*, to determine the flux profile of the chamber in conjunction with the dummy specimen (Fig. 3), shall be of the Schmidt-Boelter⁵ type, have a range from 0 W/cm² to 1.5 W/cm² (0 Btu/ft²·s to 1.32 Btu/ft²·s) and shall be calibrated over the operating flux level range from 0.01 W/cm² to 1.5 W/cm² in accordance with the procedure outlined in Annex A1. A source of 15 to 25°C cooling water shall be provided for this instrument.

6.5.1 *Voltmeter*, high-impedance or potentiometric, with a range from 0 mV to 10 mV and reading to 0.01 mV shall be used to measure the output of the total heat flux transducer during the flux profile determination.

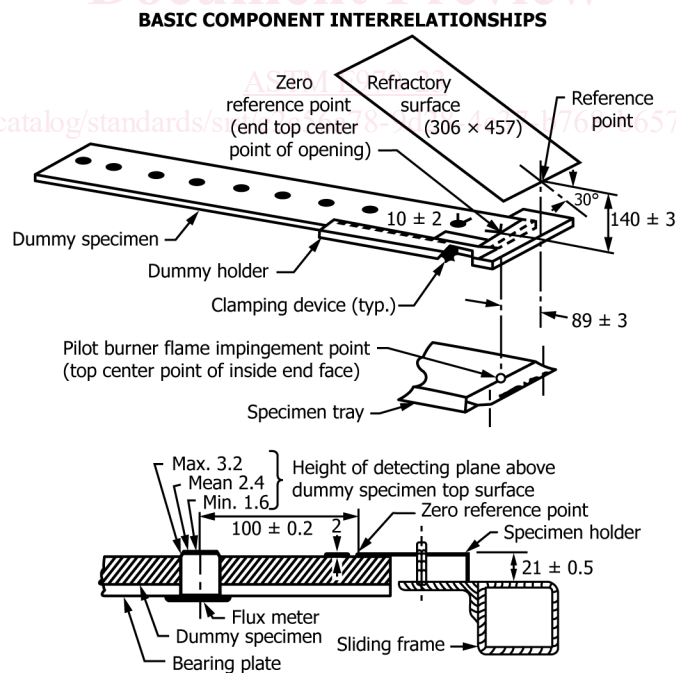

NOTE 1—All dimensions in millimetres. 1 in. = 25.4 mm.
FIG. 3 Zero Reference Point Related to Detecting Plane

⁵ The sole source of supply of the apparatus known to the committee at this time is Medtherm Corp., P.O. Box 412, Huntsville, AL 35804. If you are aware of alternative suppliers, please provide this information to ASTM headquarters. Your comments will receive careful consideration at a meeting of the responsible technical committee,¹ which you may attend.

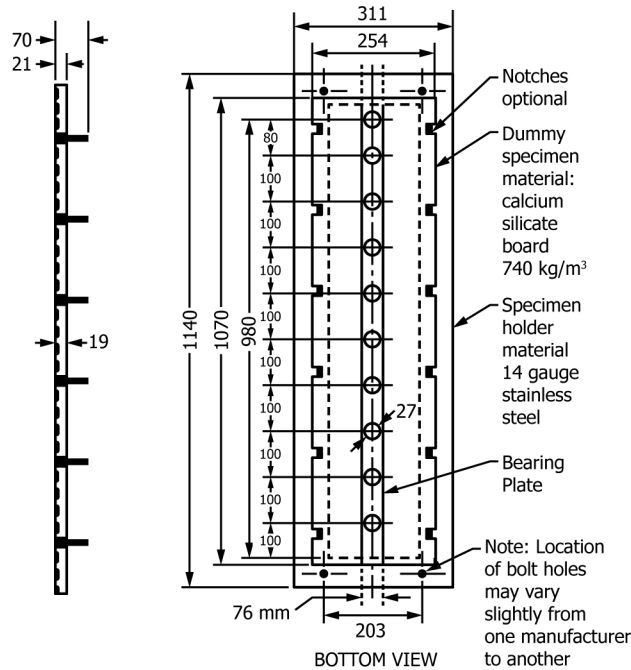

NOTE 1—All dimensions in millimetres. 1 in. = 25.4 mm.

FIG. 4 Dummy Specimen in Specimen Holder

iTeh Standards

6.6 *Specimen Tray* (Fig. 5), constructed from 14-gage heat-resistant stainless steel (UNS-N08330 (AISI Type 330) or equivalent), thickness 1.98 mm (0.078 in.). The depth of the tray is 50 mm (2 in.). The flanges of the specimen tray are drilled to accommodate two stud bolts at each end; the bottom surface of the flange is 21 mm (0.83 in.) below the top edge of the specimen tray. The overall dimensions of the tray and the width of the flanges shall be such that the tray fills the open space in the sliding platform. The tray must be adequate to contain a specimen at least 1000 mm (40 in.) long and 250 mm (10 in.) wide. The zero reference point on the dummy specimen shall coincide with the pilot burner flame impingement point (Fig. 3).

6.7 *Pilot Burner*, used to ignite the specimen, is a nominal 6 mm (1/4 in.) inside diameter, 10 mm (3/8 in.) outside diameter stainless steel tube line burner having 19 evenly spaced 0.7 mm (0.028 in.) diameter (No. 70 drill) holes drilled radially along the centerline and 16 evenly spaced 0.7 mm (0.028 in.) diameter (No. 70 drill) holes drilled radially 60 below the centerline (Fig. 6).

6.7.1 In operation, the gas⁴ flow is adjusted to 0.850.85 m²/h to 0.115 m²/h (3.0(3.0 SCFH to 4.0 SCFH) (air scale) flow rate. With the gas flow properly adjusted and the pilot burner in the test position, the pilot flame will extend from approximately 63.5 mm (2.5 in.) at the ends to approximately 127 mm (5 in.) at the center.

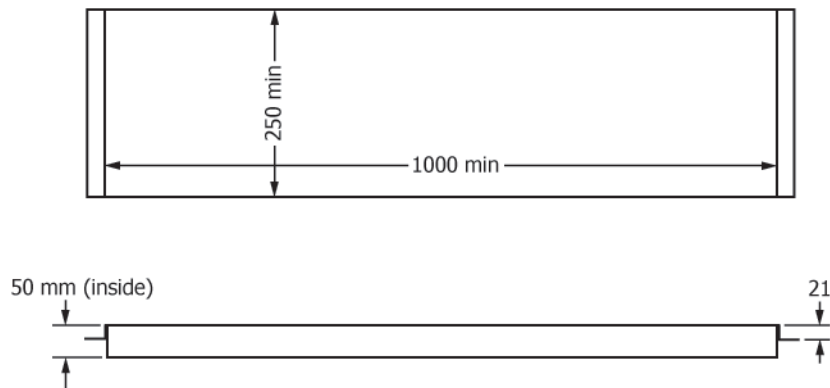

NOTE 1—All dimensions in millimetres. 1 in. = 25.4 mm.

FIG. 5 Specimen Tray