



Designation: C873/C873M – 23

Standard Test Method for Compressive Strength of Concrete Cylinders Cast in Place in Cylindrical Molds¹

This standard is issued under the fixed designation C873/C873M; the number immediately following the designation indicates the year of original adoption or, in the case of revision, the year of last revision. A number in parentheses indicates the year of last reapproval. A superscript epsilon (ϵ) indicates an editorial change since the last revision or reapproval.

1. Scope*

1.1 This test method covers the determination of strength of cylindrical concrete specimens that have been molded in place using special molds attached to formwork. This test method is limited to use in slabs where the depth of concrete is from 125 mm to 300 mm [5 in. to 12 in.].

1.2 The text of this standard refers to notes and footnotes that provide explanatory material. These notes and footnotes (excluding those in tables and figures) shall not be considered as requirements of the standard.

1.3 *Units*—The values stated in either SI units or inch-pound units are to be regarded separately as standard. The values stated in each system are not necessarily exact equivalents; therefore, to ensure conformance with the standard, each system shall be used independently of the other, and values from the two systems shall not be combined. Combining values from the two systems may result in non-conformance with the standard.

1.4 *This standard does not purport to address all of the safety concerns, if any, associated with its use. It is the responsibility of the user of this standard to establish appropriate safety, health, and environmental practices and determine the applicability of regulatory limitations prior to use. (Warning—Fresh hydraulic cementitious mixtures are caustic and may cause chemical burns to skin and tissue upon prolonged exposure.)*²

1.5 *This international standard was developed in accordance with internationally recognized principles on standardization established in the Decision on Principles for the Development of International Standards, Guides and Recommendations issued by the World Trade Organization Technical Barriers to Trade (TBT) Committee.*

¹ This test method is under the jurisdiction of ASTM Committee C09 on Concrete and Concrete Aggregates and is the direct responsibility of Subcommittee C09.61 on Testing for Strength.

Current edition approved Oct. 1, 2023. Published October 2023. Originally approved in 1977. Last previous edition approved in 2015 as C873/C873M–15. DOI: 10.1520/C0873_C0873M-23.

² Section on Safety Precautions, Manual of Aggregate and Concrete Testing, *Annual Book of ASTM Standards*, Vol 04.02.

2. Referenced Documents

2.1 *ASTM Standards*:³

C39/C39M Test Method for Compressive Strength of Cylindrical Concrete Specimens

C42/C42M Test Method for Obtaining and Testing Drilled Cores and Sawed Beams of Concrete

C470/C470M Specification for Molds for Forming Concrete Test Cylinders Vertically

C617/C617M Practice for Capping Cylindrical Concrete Specimens

C670 Practice for Preparing Precision and Bias Statements for Test Methods for Construction Materials

C1231/C1231M Practice for Use of Unbonded Caps in Determination of Compressive Strength of Hardened Cylindrical Concrete Specimens

3. Summary of Test Method

3.1 A concrete cylinder mold assembly consisting of a mold and a tubular support member is fastened within the concrete formwork prior to placement of the concrete as shown in Fig. 1. The elevation of the mold upper edge is adjusted to correspond to the level of the finished slab surface. The mold support prevents direct contact of the slab concrete with the outside of the mold and permits easy removal of the mold from the slab. The mold is filled at the time its location is reached in the normal course of concrete placement. The specimen in the “cured-in-place” condition is removed from its in-place location immediately prior to de-molding, capping, and testing. The reported compressive strength is corrected on the basis of specimen length-diameter ratio using correction factors provided in the section on calculation of Test Method C42/C42M.

4. Significance and Use

4.1 Cast-in-place cylinder strength relates to the strength of concrete in the structure due to the similarity of curing conditions because the cylinder is cured within the slab. However, due to differences in moisture condition, degree of

³ For referenced ASTM standards, visit the ASTM website, www.astm.org, or contact ASTM Customer Service at service@astm.org. For *Annual Book of ASTM Standards* volume information, refer to the standard’s Document Summary page on the ASTM website.

*A Summary of Changes section appears at the end of this standard

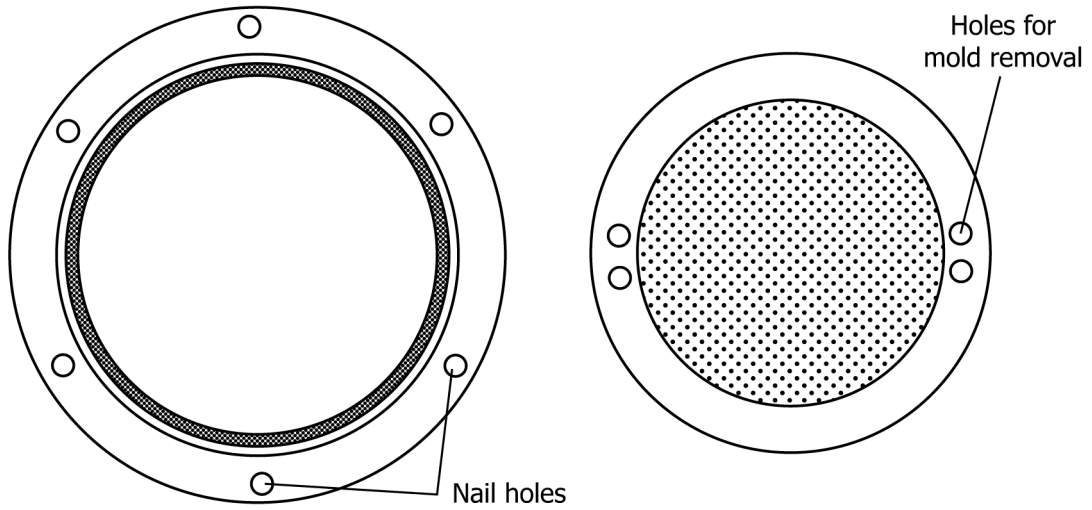

(a) Plan of support member

(b) Plan of mold

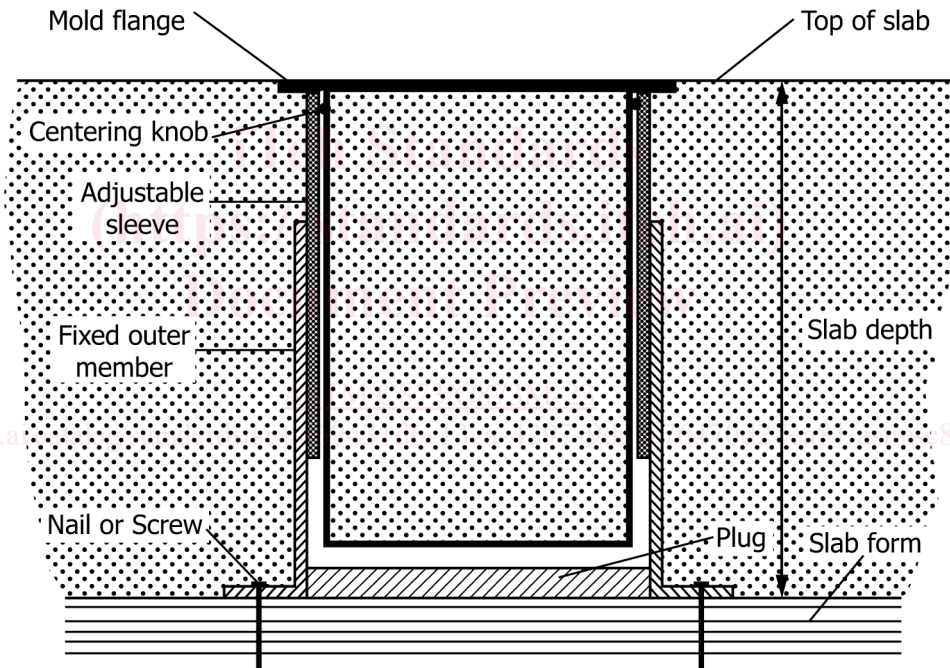

(c) Elevation of support member and mold

FIG. 1 Schematic of Cast-in-Place Cylinder Mold Assembly