



Designation: **D7332/D7332M—22 D7332/D7332M – 23**

## Standard Test Method for Measuring the Fastener Pull-Through Resistance of a Fiber-Reinforced Polymer Matrix Composite<sup>1</sup>

This standard is issued under the fixed designation D7332/D7332M; the number immediately following the designation indicates the year of original adoption or, in the case of revision, the year of last revision. A number in parentheses indicates the year of last reapproval. A superscript epsilon ( $\epsilon$ ) indicates an editorial change since the last revision or reapproval.

### 1. Scope

1.1 This test method determines the fastener pull-through resistance of multidirectional polymer matrix composites reinforced by high-modulus fibers. Fastener pull-through resistance is characterized by the force-versus-displacement response exhibited when a mechanical fastener is pulled through a composite plate, with the force applied perpendicular to the plane of the plate. The composite material forms are limited to continuous-fiber or discontinuous-fiber (tape or fabric, or both) reinforced composites for which the laminate is symmetric and balanced with respect to the test direction. The range of acceptable test laminates and thicknesses is defined in 8.2.

1.2 Two test procedures and configurations are provided. The first, Procedure A, is suitable for screening and fastener development purposes. The second, Procedure B, is configuration-dependent and is suitable for establishing design values. Both procedures can be used to perform comparative evaluations of candidate fasteners/fastener system designs.

1.3 The specimens described herein may not be representative of actual joints which may contain one or more free edges adjacent to the fastener, or may contain multiple fasteners that can change the actual boundary conditions.

1.4 This test method is consistent with the recommendations of CMH-17, which describes the desirable attributes of a fastener pull-through test method.

1.5 *Units*—The values stated in either SI units or inch-pound units are to be regarded separately as standard. The values stated in each system are not necessarily exact equivalents; therefore, to ensure conformance with the standard, each system shall be used independently of the other, and values from the two systems shall not be combined.

1.5.1 Within the text, the inch-pound units are shown in brackets.

1.6 *This standard does not purport to address all of the safety concerns, if any, associated with its use. It is the responsibility of the user of this standard to establish appropriate safety, health, and environmental practices and determine the applicability of regulatory limitations prior to use.*

1.7 *This international standard was developed in accordance with internationally recognized principles on standardization established in the Decision on Principles for the Development of International Standards, Guides and Recommendations issued by the World Trade Organization Technical Barriers to Trade (TBT) Committee.*

<sup>1</sup> This test method is under the jurisdiction of ASTM Committee D30 on Composite Materials and is the direct responsibility of Subcommittee D30.05 on Structural Test Methods.

Current edition approved May 1, 2022; Sept. 1, 2023. Published May 2022; October 2023. Originally approved in 2007. Last previous edition approved in 2016 as D7332/D7332M—16; D7332/D7332M – 22. DOI: 10.1520/D7332\_D7332M-22; 10.1520/D7332\_D7332M-23.



## 2. Referenced Documents

### 2.1 ASTM Standards:<sup>2</sup>

- D792 Test Methods for Density and Specific Gravity (Relative Density) of Plastics by Displacement
- D883 Terminology Relating to Plastics
- D2584 Test Method for Ignition Loss of Cured Reinforced Resins
- D2734 Test Methods for Void Content of Reinforced Plastics
- D3171 Test Methods for Constituent Content of Composite Materials
- D3410/D3410M Test Method for Compressive Properties of Polymer Matrix Composite Materials with Unsupported Gage Section by Shear Loading
- D3878 Terminology for Composite Materials
- D5229/D5229M Test Method for Moisture Absorption Properties and Equilibrium Conditioning of Polymer Matrix Composite Materials
- D5687/D5687M Guide for Preparation of Flat Composite Panels with Processing Guidelines for Specimen Preparation
- D8509 Guide for Test Method Selection and Test Specimen Design for Bolted Joint Related Properties
- E4 Practices for Force Calibration and Verification of Testing Machines
- E6 Terminology Relating to Methods of Mechanical Testing
- E18 Test Methods for Rockwell Hardness of Metallic Materials
- E122 Practice for Calculating Sample Size to Estimate, With Specified Precision, the Average for a Characteristic of a Lot or Process
- E177 Practice for Use of the Terms Precision and Bias in ASTM Test Methods
- E456 Terminology Relating to Quality and Statistics
- ~~E1309 Guide for Identification of Fiber-Reinforced Polymer-Matrix Composite Materials in Databases (Withdrawn 2015)<sup>3</sup>~~
- ~~E1434 Guide for Recording Mechanical Test Data of Fiber-Reinforced Composite Materials in Databases (Withdrawn 2015)<sup>3</sup>~~

### 2.2 Industry Documents:<sup>3</sup>

- CMH-17-1G Composite Materials Handbook, Volume 1—Polymer Matrix Composites Guidelines for Characterization of Structural Materials

## 3. Terminology

3.1 *Definitions*—Terminology D3878 defines terms relating to composite materials. Terminology D883 defines terms relating to plastics. Terminology E6 defines terms relating to mechanical testing. Terminology E456 and Practice E177 define terms relating to statistics. In the event of a conflict between terms, Terminology D3878 shall have precedence over the other standards.

<https://standards.iteh.ai/catalog/standards/sist/5873d8cc-ab1e-4d06-96e3-d041a5409753/astm-d7332-d7332m-23>

NOTE 1—If the term represents a physical quantity, its analytical dimensions are stated immediately following the term (or letter symbol) in fundamental dimension form, using the following ASTM standard symbology for fundamental dimensions, shown within square brackets:  $[M]$  for mass,  $[L]$  for length,  $[T]$  for time,  $[\theta]$  for thermodynamic temperature, and  $[nd]$  for non-dimensional quantities. Use of these symbols is restricted to analytical dimensions when used with square brackets, as the symbols may have other definitions when used without the brackets.

### 3.2 Definitions of Terms Specific to This Standard:

3.2.1 *diameter-to-thickness ratio,  $D/h$  [ $nd$ ]*,  $n$ —the ratio of the hole diameter to the specimen thickness.

#### 3.2.1.1 Discussion—

The diameter-to-thickness ratio may be either a nominal value determined from nominal dimensions or an actual value determined from measured dimensions.

3.2.1 Refer to Guide D8509.

3.2.2 *failure force,  $n$* —the maximum force magnitude achieved prior to the first significant (greater than 10 %) drop in applied force, as observed in force versus displacement data.

3.2.3 *initial sub-critical failure,  $n$* —discontinuity observed in force versus displacement data prior to attaining the failure force. Sub-critical failures are characterized by minor (less than 10 %) drops in applied force, or by compliance changes (greater than 10 % change in slope), prior to attaining the failure force.

<sup>2</sup> For referenced ASTM standards, visit the ASTM website, [www.astm.org](http://www.astm.org), or contact ASTM Customer Service at [service@astm.org](mailto:service@astm.org). For *Annual Book of ASTM Standards* volume information, refer to the standard's Document Summary page on the ASTM website.

<sup>3</sup> Available from SAE International (SAE), 400 Commonwealth Dr., Warrendale, PA 15096, <http://www.sae.org>.



~~3.2.4 nominal value,  $n$ —a value, existing in name only, assigned to a measurable property for the purpose of convenient designation. Tolerances may be applied to a nominal value to define an acceptable range for the property.~~

~~3.2.4 rupture,  $n$ —separation of the fastener and test laminate, caused by failure of the fastener, the composite plate, or both. Rupture is characterized by an extreme force drop, such that the specimen is incapable of carrying significant applied force.~~

### 3.3 Symbols:

$A$  = cross-sectional area of a specimen

$CV$  = coefficient of variation statistic of a sample population for a given property (in percent)

$d$  = fastener or pin shank diameter

$d_{csk}$  = countersink depth

$D$  = specimen hole diameter

$h$  = specimen thickness

$l$  = specimen length

$n$  = number of specimens per sample population

$N$  = number of plies in laminate under test

$P_f$  = failure force

$P_i$  = force carried by test specimen at initial failure

$P_m$  = maximum force carried by test specimen during test

$s_{n-1}$  = standard deviation statistic of a sample population for a given property

$w$  = specimen width

$x_i$  = test result for an individual specimen from the sample population for a given property

$\bar{x}$  = mean or average (estimate of mean) of a sample population for a given property

$\delta_i$  = displacement at initial failure

$\delta_r$  = displacement at rupture

## 4. Summary of Test Method

### 4.1 Procedure A, Compressive-Loaded Fixture:

4.1.1 Two flat square, constant rectangular cross-section composite plates, each containing a centrally located fastener hole, are placed in a multi-piece fixture that has been aligned to minimize loading eccentricities. Each plate contains four additional holes on the periphery to accommodate the test fixture components. The two plates are joined together by the fastener, with one plate being rotated 45° with respect to the second plate.

4.1.2 The plates are pried apart by the application of compressive force transmitted through the fixture, producing a tensile loading through the fastener and a compressive loading through the composite plates. Force is applied until failure of the composite specimen, the fastener, or both occurs. Applied force and crosshead displacement are recorded while loading.

### 4.2 Procedure B, Tensile-Loaded Fixture:

4.2.1 A flat square, constant rectangular cross-section composite plate containing a centrally located fastener hole is placed in a multi-piece fixture that has been aligned to minimize loading eccentricities. The plate is joined by the fastener to a yoke, which is designed to rotate as to avoid imparting a moment to the fastener.

4.2.2 A uniaxial tensile force is applied to the yoke, imparting a tensile loading on the fastener and an out-of-plane compressive loading on the composite plate. Force is applied until failure of the composite specimen, the fastener, or both occurs. Applied force and crosshead displacement are recorded while loading.

~~4.3 For both procedures, preferred~~Refer to Guide [D8509](#) ~~failure modes are those associated with failure of the composite at the fastener hole. Unacceptable failure modes include those associated with the fastener (such as head, shank, or thread failure) or failure of the composite away from the fastener hole.~~for additional test details and acceptable failure modes.

## 5. Significance and Use

~~5.1 This test method is designed to produce~~Refer to Guide [D8509](#) ~~fastener pull-through resistance data for structural design~~

allowables, research and development. The procedures may be used to assess pull-through resistance for a variety of composite laminate thicknesses, fastener diameters, and fastener head styles. However, the flexibility of test parameters allowed by the variants makes meaningful comparison between datasets difficult if the datasets were not generated using identical test parameters.

5.2 Early composite pull-through tests using fasteners common to metal structures led to premature joint failures, and resulted in the development of fasteners specific for composite applications. These fasteners have larger heads and tails to reduce through-thickness compression stresses on the composite laminate.

5.3 General factors that influence the mechanical response of composite laminates and should therefore be reported include the following: material, methods of material preparation and lay-up, specimen stacking sequence, specimen preparation, specimen conditioning, environment of testing, specimen alignment, speed of testing, time at temperature, void content, and volume percent reinforcement.

5.4 Specific factors that influence the pull-through resistance of composite laminates and should therefore be reported include the following: hole diameter, fastener diameter, fastener head diameter, loading bar spacing to fastener hole diameter ratio (Procedure A), clearance hole diameter to fastener hole diameter ratio (Procedure B), diameter to thickness ratio, fastener torque, fastener or pin material, fastener or pin clearance, countersink angle and depth of countersink, type of grommet (if used), and type of support fixture. Fastener pull-through resistance properties which may be determined from this test method include initial sub-critical failure force/displacement, failure force, maximum force, and rupture displacement.

## 6. Interferences

6.1 *Material and Specimen Preparation*—Poor material fabrication practices, lack of control of fiber alignment, and damage induced by improper specimen machining are known causes of high material data scatter in composites in general. Important aspects of specimen preparation that contribute to data scatterRefer to Guide D8509 include thickness variation, out-of-plane curvature, surface roughness, and failure to meet the dimensional tolerances specified in 8.2.2.

6.2 *Hole Preparation*—Because of the dominating presence of the filled hole, results from this test method are relatively insensitive to parameters that would be of concern in an unnotched tensile, compressive, or flexural property test. However, since the filled hole dominates the strength, consistent preparation of the hole, without damage to the laminate, is important to meaningful results. Damage caused by hole preparation will affect strength results and can reduce the calculated strength.

<https://standards.iteh.ai/catalog/standards/sist/5873d8cc-ab1e-4d06-96e3-d041a5409753/astm-d7332-d7332m-23>

6.3 *Fastener Head Style and Countersink*—Results are affected by the head style of the fastener utilized. In general, specimens containing protruding head fasteners exhibit the highest pull-through resistance forces, followed by (in order of decreasing pull-through resistance forces) 100° tension head fasteners, 100° shear head fasteners, and 130° shear head fasteners. Results may also be affected by the ratio of countersunk (flush) head depth to thickness; the preferred ratio is the range from 0.0 to 0.7 unless the experiment is investigating the influence of this ratio.

6.4 *Fastener-Hole Clearance*—Results are affected by the clearance arising from the difference between hole and fastener diameters. Excess clearance can change the observed specimen behavior by promoting the onset of sub-critical failures, due to a decrease in the effective area of the composite which reacts the pull-through load. Damage due to insufficient clearance during fastener installation will affect strength results. For these reasons, both the hole and fastener diameters must be accurately measured and recorded. A typical aerospace tolerance on fastener-hole clearance is  $+75/-0\ \mu\text{m}$  [ $+0.003/-0.000\ \text{in.}$ ] for structural fastener holes.

6.5 *Countersink Flushness*—Countersink flushness (depth or protrusion of the fastener head in a countersunk hole) will affect strength results and may affect the observed failure mode. Countersunk head fasteners shall be installed within  $\pm 0.1\ \text{mm}$  [ $\pm 0.005\ \text{in.}$ ] from the composite surface, unless otherwise specified.

6.6 *Thickness*—Results are affected by the thickness of the specimen and the ratio of hole diameter to thickness. Fastener pull-through resistance is typically proportional to the thickness of the specimen. The preferred ratio of hole diameter to thickness is the range from 1.5 to 3.0 unless the experiment is investigating the influence of this ratio. Additionally, for both procedures the composite plate(s) must have sufficient thickness, flexural stiffness and flexural strength to transmit the fixture loading without excessive plate bending, flexural failure or bearing damage.

6.7 *Fastener Torque/Pre-load*—Results are affected by the installed fastener pre-load (clamping pressure), as this force must be overcome initially by the application of tensile loading to the fastener.

6.8 *Geometry*—Results are affected by the ratio of loading bar spacing to fastener hole diameter for Procedure A tests, and by the ratio of clearance hole diameter to fastener hole diameter for Procedure B tests. The ratio should be maintained as specified in [Tables 1 and 2](#), unless the experiment is investigating the influence of this ratio.

6.9 *Test Fixture Characteristics*—The configuration of the test fixture can have a significant effect on test results. For Procedure A, friction between the composite plates and loading posts (resulting from plate flexure or hole misalignment) can cause force measurement errors and affect test results. For Procedure B, the configuration of the yoke, and its ability to minimize the applied moment to the test specimen, can affect test results. Additionally, for Procedure B the diameter of the clearance hole can affect the degree of bending in the composite plate.

6.10 *System Alignment*—Errors can result if the test fixture is not centered with respect to the loading axis of the test machine.

## 7. Apparatus

7.1 *Micrometers and Calipers*—A micrometer with a 44 mm to 8 mm [0.16 to 0.32 in.] [0.16 in. to 0.32 in.] nominal diameter ball-interface or a flat anvil interface shall be used to measure the specimen thickness. A ball interface is recommended for thickness measurements when at least one surface is irregular (for example, a coarse peel ply surface, which is neither smooth nor flat). A micrometer or caliper with a flat anvil interface shall be used for measuring length, width, and other machined surface dimensions. The use of alternative measurement devices is permitted if specified (or agreed to) by the test requestor and reported by the testing laboratory. The accuracy of the instruments shall be suitable for reading to within 1 % of the sample dimensions. For typical specimen geometries, an instrument with an accuracy of  $\pm 0.0025$  mm [ $\pm 0.0001$  in.] is adequate for thickness measurements, while an instrument with an accuracy of  $\pm 0.025$  mm [ $\pm 0.001$  in.] is adequate for measurement of length, width, and other machined surface dimensions.

7.2 *Loading Fasteners or Pins*—The fastener type shall be specified as an initial test parameter and reported. Fastener grip lengths shall be selected to ensure that the threads do not contact the laminate after pin installation. The assembly torque (if applicable) shall be specified as an initial test parameter and reported. This value may be a measured torque or a specification torque for fasteners with lock-setting features. If washers are utilized, the washer type, number of washers, and washer location(s) shall be specified as initial test parameters and reported. The reuse of fasteners is not recommended due to potential differences in through-thickness clamp-up for a given torque level, caused by wear of the threads or deformation of the locking features.

7.3 *Torque Wrench*—If using a torqued fastener, a torque wrench used to tighten the fastener shall be capable of determining the applied torque to within  $\pm 10$  % of the desired value.

### 7.4 Support Fixture:

7.4.1 *Procedure A*—The test fixture for Procedure A, shown in [Fig. 1](#), consists of two symmetric components, each of which consists of a base and four cylindrical supports, evenly spaced around the circumference of the base. When the composite plates are assembled within the fixture, the application of compressive force to the fixture imparts a compressive loading to the plates and tensile loading to the fastener.

7.4.2 *Procedure B*—The test fixture for Procedure B, shown in [Fig. 2](#), consists of a rigid base plate, a channel section with a clearance hole, fasteners to secure the channel section to the base, and a loading yoke. When the composite specimen is placed within the fixture, the application of tensile force to the loading yoke imparts a compressive loading to the specimen and tensile loading to the fastener.

7.4.3 *Support Fixture Details*—The support fixture shall be constructed of sufficient stiffness and precision as to satisfy the loading uniformity requirements of this test method. The following general notes apply to these figures:

7.4.3.1 Machine surfaces to a 3.2 [125] rms surface finish unless otherwise specified.

7.4.3.2 Break all edges.

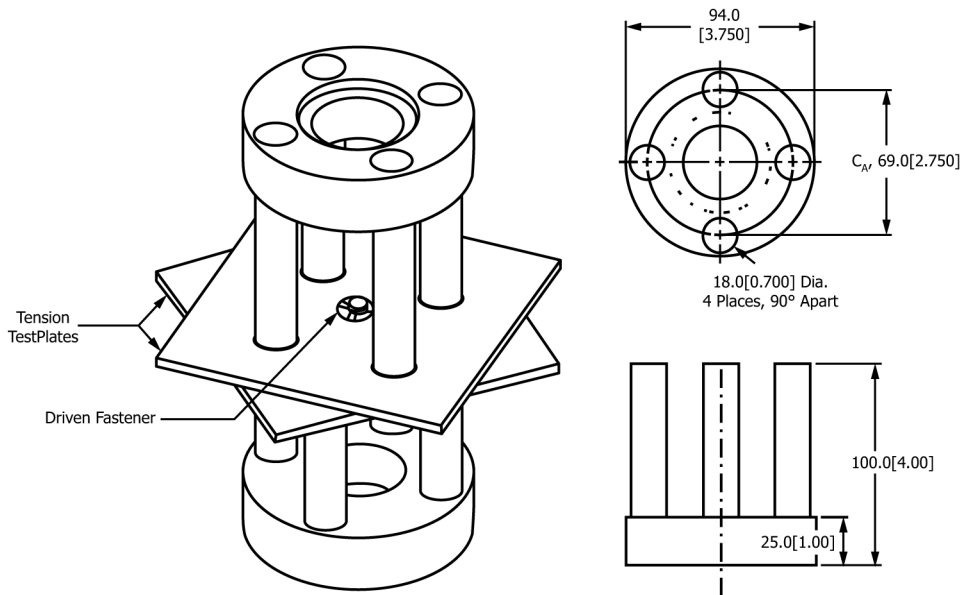

NOTE 1—All dimensions in millimetres [inches] unless otherwise specified.  
 NOTE 2—Dimensional tolerances are linear  $\pm 0.5$  mm [ $\pm 0.02$  in.], angular  $\pm 0.5$  degrees.  
 NOTE 3—Break all edges.

FIG. 1 Fastener Pull-Through Test Fixture, Procedure A

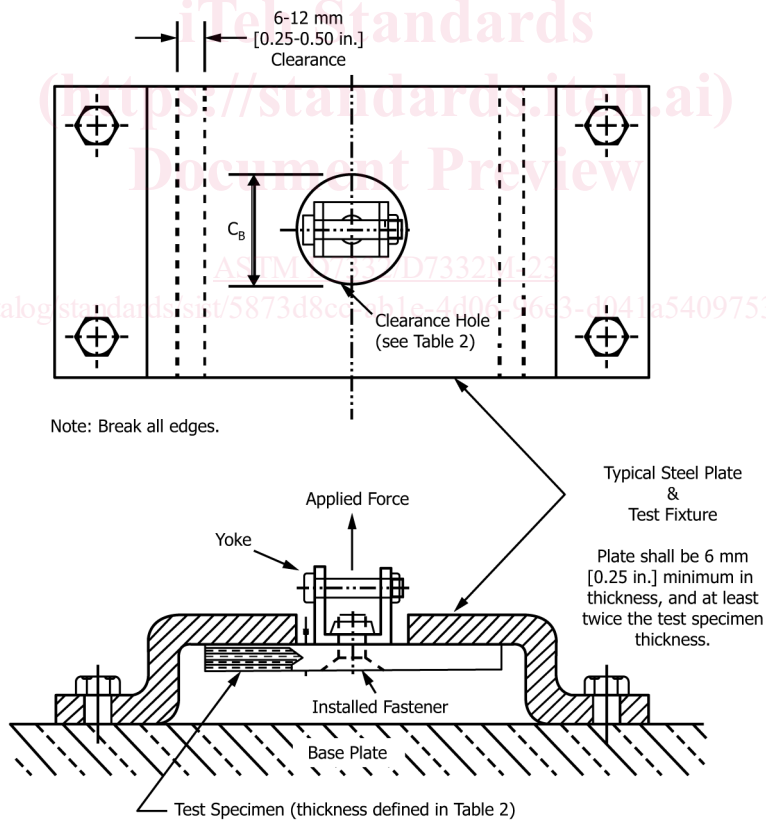

FIG. 2 Fastener Pull-Through Test Fixture, Procedure B

7.4.3.3 The test fixture shall be made of steel. It may be made of low carbon steel for ambient temperature testing. For non-ambient environmental conditions, the recommended fixture material is a nonheat-treated ferritic or precipitation hardened stainless steel (heat treatment for improved durability is acceptable but not required).