



Designation: D8041/D8041M – 16 (Reapproved 2023)

## Standard Test Method for Whole Boot Breathability (MVTR)<sup>1</sup>

This standard is issued under the fixed designation D8041/D8041M; the number immediately following the designation indicates the year of original adoption or, in the case of revision, the year of last revision. A number in parentheses indicates the year of last reapproval. A superscript epsilon ( $\epsilon$ ) indicates an editorial change since the last revision or reapproval.

### 1. Scope

1.1 The whole boot breathability test method is designed to indicate the Moisture Vapor Transmission Rate (MVTR) through the boot upper by means of a difference in temperature and moisture vapor concentration between the interior of the boot and the exterior environment. This method is intended for a size 10 R U.S. (Regular width) boot that is at least 6 in. [15.2 cm] tall above the insole.

1.2 The values stated in either inch-pound units or SI units are to be regarded separately as standard. Within the text, the SI units are shown in brackets. The values stated in each system are not exact equivalents; therefore, each system is to be used independently of the other, without combining values in any way. Combining values from the two systems may result in non-conformance with the standard.

1.3 *This standard does not purport to address all of the safety concerns, if any, associated with its use. It is the responsibility of the user of this standard to establish appropriate safety, health, and environmental practices and determine the applicability of regulatory limitations prior to use.*

1.4 *This international standard was developed in accordance with internationally recognized principles on standardization established in the Decision on Principles for the Development of International Standards, Guides and Recommendations issued by the World Trade Organization Technical Barriers to Trade (TBT) Committee.*

### 2. Terminology

#### 2.1 Definitions:

2.1.1 *boot, n*—footwear in which the upper reaches above the ankle.

2.1.2 *eyelet, n*—textile, metal or plastic reinforcements around the holes which carry the lace.

2.1.3 *foot form assembly, n*—relating to this test method, the foot form consists of boot plug with copper tubing in a shape of a foot.

2.1.4 *footwear, n*—wearing apparel for feet (such as shoes, boots, slippers).

2.1.5 *gusset, n*—the part of the vamp that extends over the instep of the foot between the eyestays and allows expansions of the opening at the top of the footwear.

2.1.5.1 *Discussion*—For slip-on footwear this may include an elastic gusset that allows expansion at the opening at the top of the footwear.

2.1.6 *heel, n*—the part of the boot which supports the back part of the foot.

2.1.7 *insert, n*—removable foot bed which is shaped or molded to match the approximate contour of the bottom surface of the foot.

2.1.8 *plug, n*—a circular or oval shaped (non metallic) boot plug that holds the (copper foot form) water heating assembly and seals the top of the water holding bootie insert and upper at the water interface. The plug must be made from material that is impervious to both liquid water and water vapor.

2.1.9 *sole or outsole, n*—the bottom layer of the footwear, including the heel, in contact with the ground forming the walking surface.

2.1.10 *upper, n*—the entire part of the footwear located above the sole. Includes external leather and synthetic materials as well as internal linings.

2.1.11 *water holding bootie insert (WHBI), n*—a thin, flexible, waterproof, breathable bootie meeting the requirements of 6.3.

### 3. Summary of Test Method

3.1 A test sample boot fitted with a water holding bootie insert (WHBI) is filled with preheated water and weighed. The water is kept at a constant temperature for 6 h and then the boot (with water) is reweighed. The loss in weight is used to calculate the Moisture Vapor Transmission Rate (MVTR) of the footwear, otherwise known as breathability.

### 4. Significance and Use

4.1 The materials and construction methods used in the manufacture of footwear play a significant role in the “breathability” of the footwear. This test method provides a means to measure moisture vapor permeability, expressed as MVTR, which is one aspect of comfort of the footwear.

<sup>1</sup> This test method is under the jurisdiction of ASTM Committee D31 on Leather and is the direct responsibility of Subcommittee D31.03 on Footwear.

Current edition approved Oct. 1, 2023. Published October 2023. Originally approved in 2016. Last previous edition approved in 2016 as D8041/D8041M – 16. DOI: 10.1520/D8041\_D8041M-16R23.

## 5. Interferences

5.1 Temperature, humidity or air movement fluctuations.

## 6. Apparatus

6.1 The external test environment control system shall be capable of maintaining  $73\text{ °F} \pm 2\text{ °F}$  [ $23.0\text{ °C} \pm 1.0\text{ °C}$ ] and  $50\% \pm 2\%$  relative humidity throughout the test duration.

6.2 The weight scale shall be capable of determining weight of boot, plus foot form assembly and WHBI filled with water to an accuracy of  $\pm 0.1\text{ g}$ .

6.3 The WHBI shall be flexible so that it can be inserted into the boot and conform to the interior contours; it must be thin enough so that folds do not create air gaps. The WHBI must be waterproof so that only moisture vapor can penetrate through the bootie, rather than liquid water. Check the WHBI for leakage before each test by filling the interior with water and visually looking for water moisture on the exterior surface. A WHBI should only be used for five 6-h tests, including the first conditioning test (see 11.2).

6.4 The foot-form assembly used with the water circulating system is constructed of  $\frac{1}{4}$ -in. or  $\frac{3}{8}$ -in. [6 mm or 10 mm] OD copper tubing passing through the boot plug. (See the critical dimensions for the diameter, horizontal and vertical tubing lengths in Fig. 1.) The tubing is measured from the bottom of the plug surface to the end of the elbow or bend.

6.5 The boot plug (Fig. 2) shall be circular shaped measuring  $3\text{-}\frac{1}{2}$  in. diameter by  $2\text{-}\frac{1}{2}$  in. thick  $\pm \frac{1}{2}$  in. [89 mm diameter by 64 mm] or an oval  $2\text{-}\frac{1}{2}$  in. wide by  $3\text{-}\frac{1}{2}$  in. long by  $2\text{-}\frac{1}{2}$  in. thick [64 mm by 89 mm by 64 mm], nonmetallic, and impervious to water vapor and liquid water.

NOTE 1—Critical measurements are plug thickness and ensuring probe is 1 in. [2.54 cm] from inside edge of tubing.

6.5.1 In addition, the boot plug shall have a water filling hole with stopper and at least one temperature probe, (6.6) which will be used to monitor the internal water temperature in the WHBI at the toe area of the boot (see Fig. 1). The foot form assembly is detachable from the water circulating system (6.7) to facilitate weighing. Both the inlet and outlet lines from the foot form assembly to the water circulating system shall consist of clear tubing, each marked with a line or alternate means to ensure the water volume within the system is constant during weighing.

6.6 There is one temperature probe (see Fig. 1) which is inserted into the top of the boot plug and reaches to the toe area of the boot. It cannot be wrapped around, or come in contact with, the copper tubing. Note that all tubes, hoses or lines running through the plug shall be sealed to prevent vapor from escaping.

6.7 The water circulating system (see Fig. 3) for the boot shall be capable of controlling the temperature of the water in the boot uniformly at  $95\text{ °F} \pm 2\text{ °F}$  [ $35\text{ °C} \pm 1\text{ °C}$ ] when measured with the temperature probe, without touching the WHBI or water circulating apparatus. (See Fig. 1).

6.8 A stationary 6 in. [15.2 cm] diameter fan shall be used to create the specified air current past the boot.

6.9 The stationary fan shall be positioned perpendicular to the test surface, aimed at the toe of the boot, and be raised so the center of the fan is 5 in. [12.7 cm] above the base of the test platform.

6.10 The air current origin shall be 15.5 in. [39.4 cm] from the back heel edge of the boot (*D*). Refer to Fig. 4.

6.11 The wind speed shall be  $250\text{ ft/min} \pm 30\text{ ft/min}$  [ $1.3\text{ m/s} \pm 0.15\text{ m/s}$ ] at the heel edge of the boot (*S*) as measured with a 2.8 in. [7.1 cm] diameter fan anemometer. Measurement shall be taken without the boot assembly in place, utilizing a holding device to support the 2.8 in. [7.1 cm] diameter fan anemometer perpendicular to the test platform. The center of the anemometer shall be 2 in. [5 cm] above the base of the test platform and 15.5 in. [39.4 cm] from the fan.

## 7. Whole Boot Breathability Bench-top Set-up

7.1 *D*—Distance from the boot heel back edge to fan surface.

7.2 *S*—Wind speed at boot heel back edge.

7.3 If there is more than one station, a divider wall must be between them. Divider walls shall be a minimum of 4 in. [10 cm] from the center line of the fan box, equal in height to the fan box, and extend from the fan box to the back of the test platform.

7.4 The fan box may need baffles, an adjustable rheostat or a variable autotransformer to meet requirements for the air current to be  $250\text{ ft/min} \pm 30\text{ ft/min}$  [ $1.3\text{ m/s} \pm 0.15\text{ m/s}$ ].

## 8. Reagents and Materials

8.1 Distilled or deionized water.

## 9. Water Holding Bootie Insert (WHBI) Test

9.1 Weigh WHBI to accuracy of  $\pm 0.1\text{ g}$ . This is the original weight and used if the test is aborted to verify the WHBI is dry before using it for testing.

9.2 The top of the WHBI shall be sealed around the foot-form assembly plug using boot laces or hook and loop bundling tape. A stand and clamp can be used to help hold the WHBI upright (see Fig. 5). Fill with distilled or deionized water preheated to  $95\text{ °F} \pm 2\text{ °F}$  [ $35\text{ °C} \pm 1\text{ °C}$ ] to just past the bottom of the plug.

9.3 Check the WHBI for any leakage before continuing the test. If any moisture is observed on the exterior surface, the test must be restarted with a new WHBI.

9.4 Weigh the entire assembly and record as  $W_i$ . The water volume in the tubing system shall be noted at the time of weighing, by a visual mark or alternate means of ensuring constant water volume. The volume of water in the tubing system shall be the same at the start and end of the test to prevent any effect on the weight loss calculation.

NOTE 2—You may need to add or remove water from the tubing system in order to ensure it is the same volume.

9.5 After weighing, connect the water circulating system and maintain the temperature in the WHBI at  $95\text{ °F} \pm 2\text{ °F}$  [ $35\text{ °C} \pm 1\text{ °C}$ ] for  $1\text{ h} \pm 5\text{ min}$ .

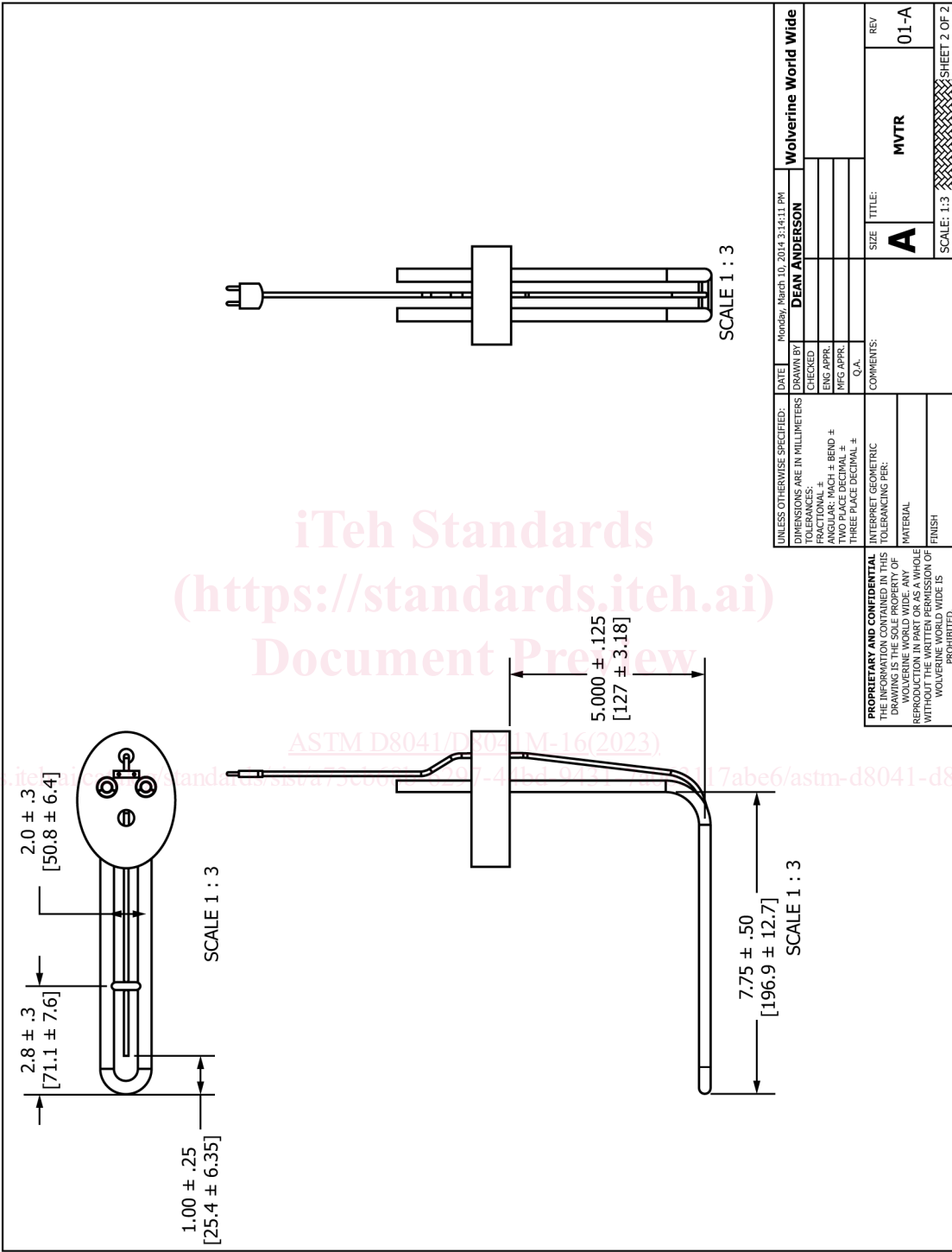
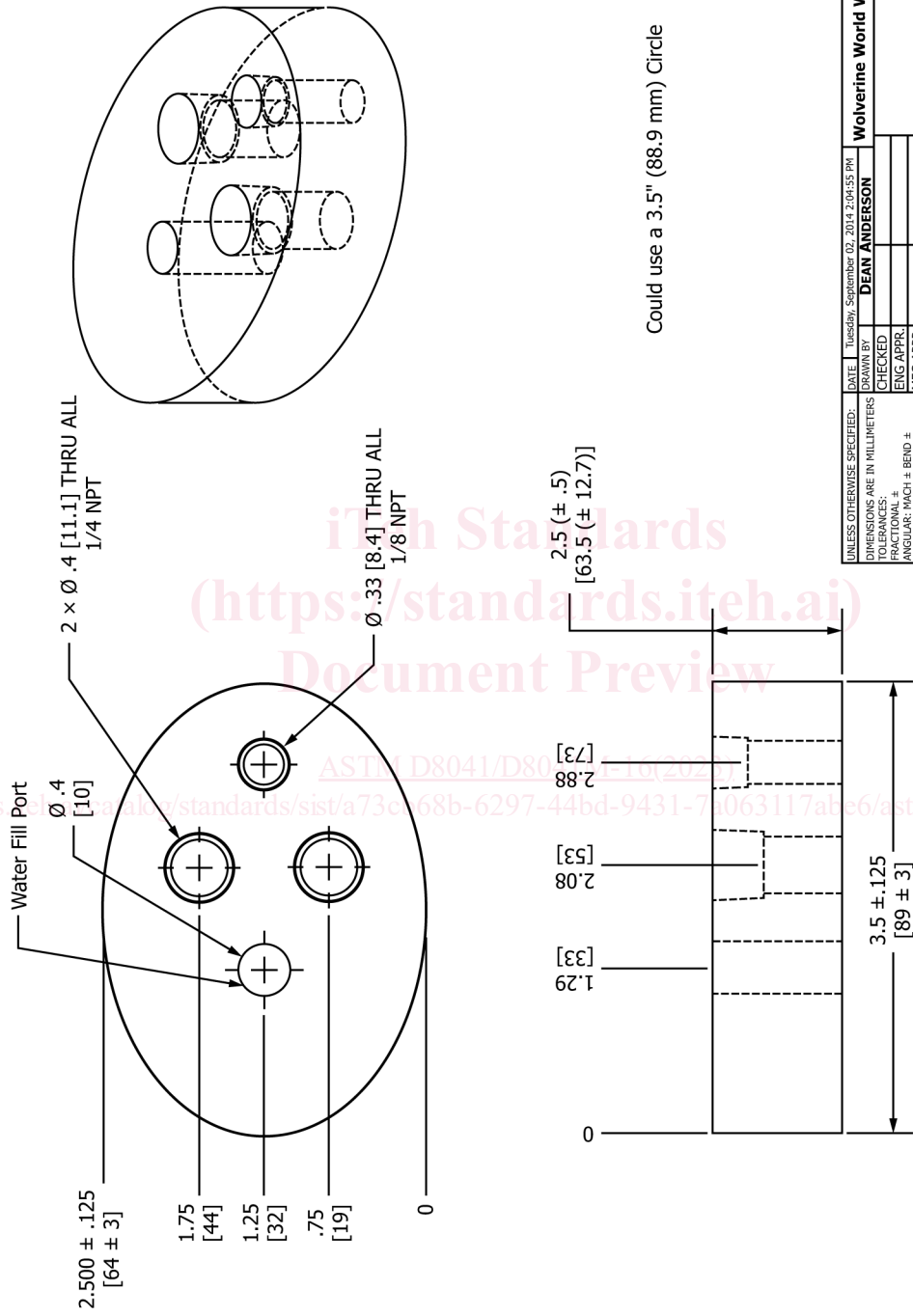

FIG. 1 Dimensions for Diameter, Horizontal and Vertical Tubing Lengths

SOURCE: Wolverine World Wide



UNLESS OTHERWISE SPECIFIED: DIMENSIONS ARE IN MILLIMETERS FRACTIONAL ± ANGULAR: MACH ± BEND ± TWO PLACE DECIMAL ± THREE PLACE DECIMAL ±	DATE: Tuesday, September 02, 2014 2:04:55 PM DRAWN BY: DEAN ANDERSON	Wolverine World Wide
PROPRIETARY AND CONFIDENTIAL THE INFORMATION CONTAINED IN THIS DRAWING IS THE PROPERTY OF WOLVERINE WORLD WIDE. ANY REPRODUCTION IN PART OR AS A WHOLE WITHOUT THE WRITTEN PERMISSION OF WOLVERINE WORLD WIDE IS PROHIBITED.	CHECKED: _____ ENG APPR: _____ MFG APPR: _____ Q.A.: _____	REV: 01-B
INTERPRET GEOMETRIC TOLERANCING PER: _____	COMMENTS: _____	SCALE: 1:1
MATERIAL: _____	SIZE: A	TITLE: MVTR
FINISH: _____		SHEET 2 OF 2

FIG. 2 Boot Plug

SOURCE: Wolverine World Wide



FIG. 3 Water Circulating System

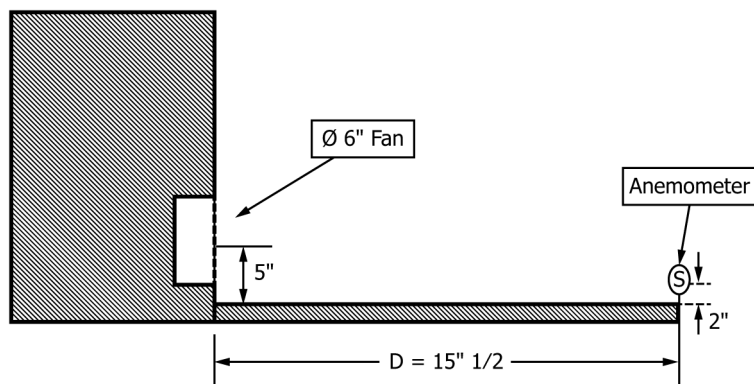

FIG. 4 Air Current Origin

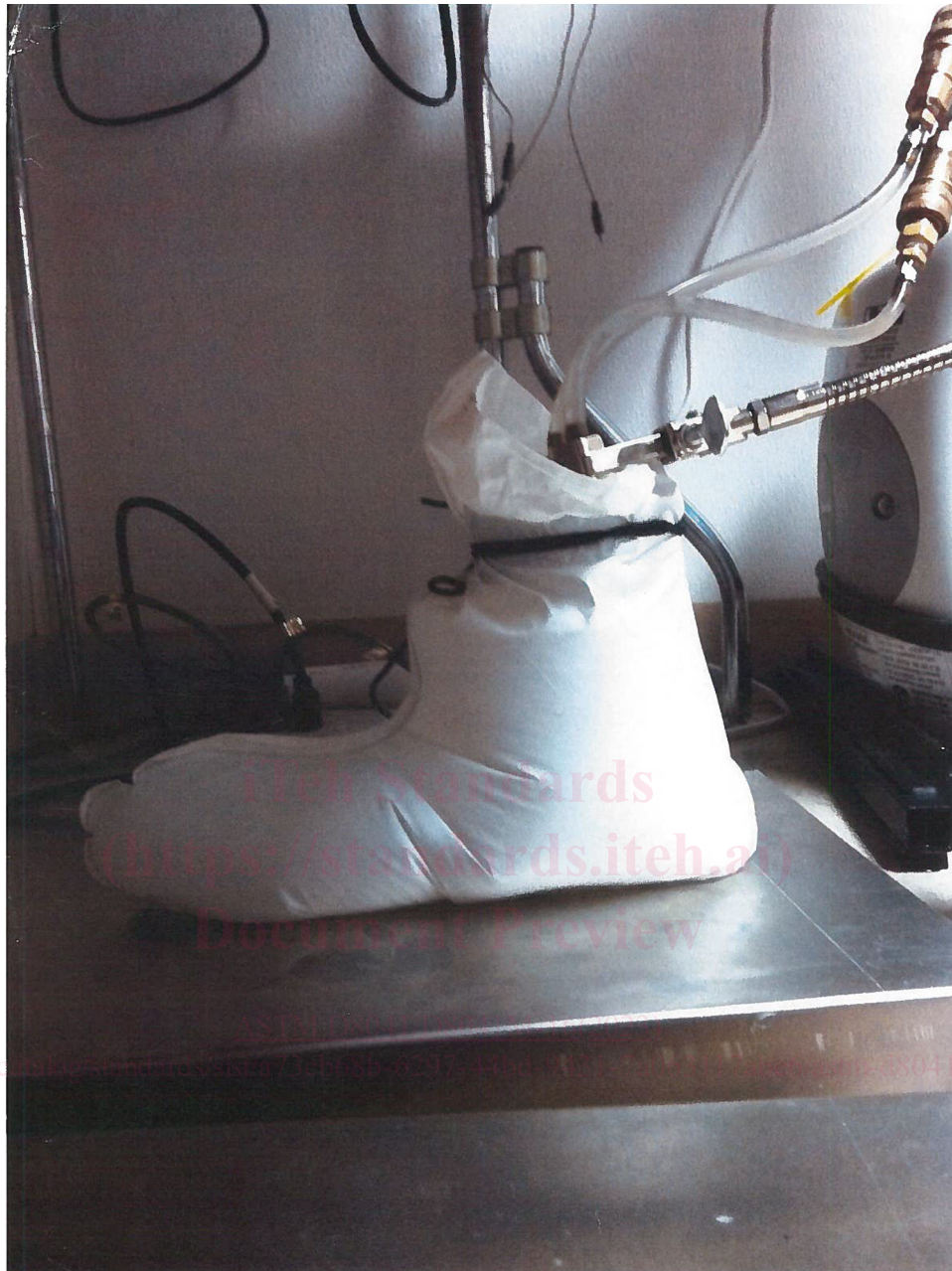

FIG. 5 Stand and Clamp

NOTE 3—Water circulating system may need adjusting to maintain constant temperature in WHBI.

9.5.1 Check the temperature every 15 min. If found out of tolerance, abort the test. If testing apparatus is capable of testing more than one WHBI at a time, the temperature of each WHBI shall be checked.

9.6 The WHBI assembly shall be oriented such that the bottom of WHBI sits flat on the testing surface and the heel of the WHBI is furthest from the fan and in line with the center of the fan (see Fig. 6).

9.7 After 1 h ( $\pm 5$  min) disconnect bootie assembly from the water circulating system and reweigh WHBI assembly as  $W_f$ . The volume of the water in the tubing system shall be the same

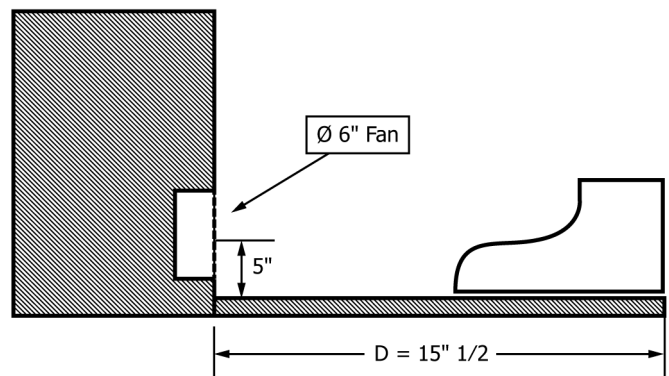

FIG. 6 Whole Boot Breathability Bench-top Set-up with WHBI