



Designation: **E3060–16** E3060 – 23

Standard Guide for Subvisible Particle Measurement in Biopharmaceutical Manufacturing Using Dynamic (Flow) Imaging Microscopy¹

This standard is issued under the fixed designation E3060; the number immediately following the designation indicates the year of original adoption or, in the case of revision, the year of last revision. A number in parentheses indicates the year of last reappraisal. A superscript epsilon (ϵ) indicates an editorial change since the last revision or reappraisal.

1. Scope

1.1 Biotherapeutic drugs and vaccines are susceptible to inherent protein aggregate formation which may change over the product shelf life. Intrinsic particles, including excipients, silicone oil, and other particles from the process, container/closures, equipment or delivery devices, and extrinsic particles which originate from sources outside of the contained process, may also be present. Monitoring and identifying the source of the subvisible particles throughout the product life cycle (from initial characterization and formulation through finished product expiry) can optimize product development, process design, improve process control, improve the manufacturing process, and ensure lot-to-lot consistency.

1.2 Understanding the nature of particles and their source is a key to the ability to take actions to adjust the manufacturing process to ensure final product quality. Dynamic imaging microscopy (also known as flow imaging or flow microscopy) is a useful technique for particle analysis and characterization (proteinaceous and other types) during product development, in-process and commercial release with a sensitive detection and characterization of subvisible particles at ≥ 2 and ≤ 100 micrometers $\geq 2 \mu\text{m}$ and $\leq 100 \mu\text{m}$ (although smaller and larger particles may also be reported if data are available). In this technique brightfield illumination is used to capture images either directly in a process stream, or as a continuous sample stream passes through a flow cell positioned in the field of view of an imaging system. An algorithm performs a particle detection routine. This process is a key step during dynamic imaging. The digital particle images in the sample are processed by image morphology analysis software that quantifies the particles in size, count, image intensity, and other morphological parameters. Dynamic imaging particle analyzers can produce direct determinations of the particle count per unit volume (that is, particle concentration), as a function of particle size by dividing the particle count by the volume of imaged fluid (see [Appendix XI](#)).

1.3 This guide will describe best practices and considerations in applying dynamic imaging to identification of potential sources and causes of particles during biomanufacturing. These results can be used to monitor these particles and where possible, to adjust the manufacturing process to avoid their formation. This guide will also address the fundamental principles of dynamic imaging analysis including image analysis methods, sample preparation, instrument calibration and verification and data reporting.

1.4 The values stated in SI units are to be regarded as standard. No other units of measurement are included in this standard.

1.5 *This standard does not purport to address all of the safety concerns, if any, associated with its use. It is the responsibility of the user of this standard to establish appropriate safety and health, safety, health, and environmental practices and determine the applicability of regulatory limitations prior to use.*

1.6 *This international standard was developed in accordance with internationally recognized principles on standardization established in the Decision on Principles for the Development of International Standards, Guides and Recommendations issued by the World Trade Organization Technical Barriers to Trade (TBT) Committee.*

¹ This guide is under the jurisdiction of ASTM Committee E55 on Manufacture of Pharmaceutical and Biopharmaceutical Products and is the direct responsibility of Subcommittee E55.14E55.03 on Measurement Systems and Analysis-General Pharmaceutical Standards.

Current edition approved June 1, 2016 Oct. 1, 2023. Published June 2016 October 2023. Originally approved in 2016. Last previous edition approved in 2016 as E3060 – 16. DOI: [10.1520/E3060-16](https://doi.org/10.1520/E3060-16), [10.1520/E3060-23](https://doi.org/10.1520/E3060-23).

2. Referenced Documents

2.1 ASTM Standards:²

[E2589 Terminology Relating to Nonsieving Methods of Powder Characterization](#)

2.2 ISO Standards:³

[ISO 28593951-1 Sampling Procedures for Inspection by Attributes Variables](#)

[ISO 8871 Elastomeric Parts for Parenterals and for Devices for Pharmaceutical Use](#)

[ISO 9276-6 Representation of Results of Particle Size Analysis Part 6: Descriptive and Quantitative Representation of Particle Shape and Morphology](#)

2.3 Other Standards:

[ANSI/ASQ Z1.4-2003Z1.9-2003 Sampling Procedures and Tables for Inspection by Attributes Variables for Percent Nonconforming³](#)

[ASME BPE-2014BPE-2022 Bioprocessing Equipment⁴](#)

~~[BS 6001-1:1999+A1:2011 Sampling procedures for inspection by attributes. Sampling schemes indexed by acceptance quality limit \(AQL\) for lot-by-lot inspection⁵](#)~~

[USP <787> Subvisible Particulate Matter in Therapeutic Protein Injections⁵](#)

[USP <788> Particulate Matter in Injections⁵](#)

[USP <1663> Assessment of Extractables Associated with Pharmaceutical Packaging/Delivery Systems⁵](#)

[USP <1664> Assessment of Drug Product Leachables Associated with Pharmaceutical Packaging Delivery Systems⁵](#)

[USP <1787> Measurement of Subvisible Particulate Matter in Therapeutic Protein Injections⁵](#)

[USP <1788> Methods for Determination of Subvisible Particulate Matter⁵](#)

[USP <1788.3> Flow Imaging Method for the Determination of Subvisible Particulate Matter⁵](#)

3. Terminology

3.1 Definitions:

3.1.1 For definitions of terms used in this standard, refer to Terminology [E2589](#).

3.2 Definitions of Terms Specific to This Standard:

3.2.1 *aspect ratio, n*—ratio of particle width to particle length.

3.2.1.1 Discussion—

The definition of particle width and length depends on the image analysis software being used, and reported aspect ratio may not be interchangeable between different software packages.

3.2.2 *binary image, n*—a transformation of a camera image into pixels identified as particles and pixels identified as background.

3.2.3 *brightfield illumination, n*—a method of providing light into a measurement space whereby the illuminated objects are located between the light source and the viewing receiver.

3.2.4 *circularity, n*—degree to which a particle (or its projection area) is similar to a circle, mathematically expressed as $4\pi A/P^2$, where A is particle area and P is particle perimeter.

3.2.5 *cumulative particle size distribution, n*—a representation, as a table, graph, or mathematical function, that gives the total fraction or concentration of particles greater than or less than a set of specified size values.

3.2.5.1 Discussion—

Cumulative particle size distributions may be expressed as either mass, volume, area, number, or concentration values.

3.2.6 *depth of field, n*—~~depth of field is the distance~~ the distance along the optical axis between the nearest and farthest objects that are in acceptably sharp focus in an image.

² For referenced ASTM standards, visit the ASTM website, www.astm.org, or contact ASTM Customer Service at service@astm.org. For *Annual Book of ASTM Standards* volume information, refer to the standard's Document Summary page on the ASTM website.

³ Available from American National Standards Institute (ANSI), 25 W. 43rd St., 4th Floor, New York, NY 10036, <http://www.ansi.org>.

⁴ Available from American Society of Mechanical Engineers (ASME), ASME International Headquarters, Two Park Ave., New York, NY 10016-5990, <http://www.asme.org>.

⁵ Available from U.S. Pharmacopeial Convention (USP), 12601 Twinbrook Pkwy., Rockville, MD 20852-1790, <http://www.usp.org>.

3.2.7 *dynamic imaging, n*—particle size and shape analysis using computer image analysis techniques on instantaneously captured still frame projected images of particles in motion (also referred to as *flow imaging, flow microscopy, direct imaging*).

3.2.8 *equivalent diameter, n*—the diameter of a sphere or circle ~~that is equal to the measured diameter obtained with the same particle volume or area measured by a particle sizing instrument.~~

3.2.8.1 *Discussion—*

For dynamic imaging, the ~~reported~~equivalent diameter is based on calculated from the projected area of a measured particle.

3.2.8.2 *Discussion—*

Depending on the choice of software and software settings, the projected area may have any holes in the image filled or left unfilled.

3.2.9 *extrinsic particle, n*—~~a~~ an unexpected particle introduced from sources that are foreign or external to the manufacturing process.

3.2.10 *Feret diameter, F, n*—apparent diameter of an object determined from the distance between two parallel tangents on opposite sides of a binary object.

3.2.10.1 *Discussion—*

There are an infinite number of ~~Feret's~~Feret diameters; the maximum and the minimum ~~Feret's~~Feret find most use within imaging.

3.2.11 *field of view, n*—the two dimensional, lateral extent of the imaged area.

3.2.12 *frequency distribution, n*—a representation, as a table, graph, or mathematical function, that gives the frequency or count of values within a set of specified intervals.

3.2.13 *inherent particle, n*—a particle made entirely of components of the formulated drug product or its manufacturing intermediate, arising from the product itself.

3.2.14 *intrinsic particle, n*—a particle composed of materials that the product or intermediate contacts or is mixed with during the manufacturing process or during storage in primary packaging components.

3.2.15 *particle, n*—mobile, self-contained, and undissolved objects.

3.2.15.1 *Discussion—*

In the context of particle counting instruments, the term particle may be used to designate any self contained object that is optically distinguishable from the background image, including a liquid droplet or gas-phase bubble.

3.2.16 *particle size distribution (PSD), n*—a frequency or volume distribution of the concentration of particles versus particle size.

3.2.16.1 *Discussion—*

Dynamic imaging particle analyzers of use to the biopharmaceutical industry report the PSD as the concentration of particles per unit volume within specified size ranges, where the size is most commonly the equivalent diameter but may be another morphological size attribute. See [Appendix X1](#).

3.2.17 *subvisible particle, n*—a particle with a measured equivalent diameter within the approximate range 1 μm to ~~400 μm .~~ 100 μm .

NOTE 1—When it is necessary to specify an exact size range, the range should be defined explicitly rather than by such adjectives as subvisible.

3.2.14.1 *Discussion—*

~~The term particle may be used to designate any self-contained object that is optically distinguishable from the background image, including liquid droplets and gas-phase bubbles.~~

3.2.17.1 *Discussion—*

The 100 μm upper limit is based on the historical definition of subvisible particle as used in the field of drug inspection. Particles of 20 μm or smaller of sufficient optical contrast are readily visible under bright illumination, especially when present in numerous quantity.

3.2.18 *threshold, n*—the minimum quantitative change in intensity (of either positive or negative sign) from the background pixel value for a pixel to be identified as a possible particle.

3.2.19 *volume distribution, n*—a frequency distribution that gives the distribution of particle volume as a function of particle size.

4. Significance and Use

4.1 This guide will encompass considerations for manufacturers regarding sources and potential causes of subvisible particles in biomanufacturing operations and the use of dynamic imaging particle analyzers as a suggested common method to monitor them. The guide will address the following components of particle analysis using dynamic imaging microscopy: fundamental principles, operation, image analysis methods, sample handling, instrument calibration, and data reporting.

5. Types of Particles

5.1 USP <1787> defines three subcategories of particles related to their source or nature. When combined with appropriate strategies for characterizing particle types, this categorization scheme provides a framework for assessing the root cause and acceptable concentrations of different types of particles.

5.1.1 Inherent particles are related to the product formulation (for example, chemical and physical properties and concentration of the Active Pharmaceutical Ingredient (API) proteins, excipients, API solid suspensions, emulsions, adjuvant aluminum salts added to vaccines). Packaging of the product and external stresses (including temperature, mechanical shock or movement, light exposure, and interaction with liquid/solid and liquid/air interfaces) can all have substantial impact on the concentration and characteristics of protein aggregates. Protein aggregates may change over time, in both concentration and characteristics, and some levels of protein degradation or related aggregation, or both, may be expected. Inherent particles must be well characterized and monitored over the product shelf-life.

5.1.2 Intrinsic particles include product contact materials from the manufacturing process or primary packaging components (that is, silicone oil, glass, stainless steel, rubber closure, polymer tubing, semi-solid silicone lubricant, process related fibers, etc.). This category also includes stability-indicating particles found predominantly during development or stability studies (formulation degradation, container closure-related, glass delamination, stopper degradation, etc.). The presence of intrinsic particle types must be minimized, and if they are stability-indicating, they should be eliminated whenever possible.

5.1.3 Extrinsic particles comprise any particles not sourced from the manufacturing process or product contact materials including particles of a biological source (that is, external environmental fibers, hair, airborne particles, etc.). Extrinsic particle types should be a rare occurrence and eliminated.

6. Sources of Particles

6.1 Subvisible particles may be generated by a number of sources during the manufacturing process. In analyzing the risk of particle generation introduced by various process steps, it is useful to understand the sensitivity of the drug product or substance to a variety of stresses known to promote particle formation.

6.2 Sources of Inherent Particles:

6.2.1 Stresses which may cause inherent particle changes may include:

6.2.1.1 Interaction with interfaces or other particles.

- (1) Increased interfacial transport resulting from agitation, stirring, etc.
- (2) Interfacial adsorption: both liquid/vapor and liquid/solid
- (3) Nucleation on other particles
- (4) Trace metals and other molecules promoting oxidation and aggregation

6.2.1.2 Chemical environment.

- (1) Formulation, which may promote or hinder particle generation
- (2) Excipients
- (3) Impurities

6.2.1.3 Physical environment.

- (1) Vibration
- (2) Mechanical shock
- (3) Cavitation
- (4) Temperature and humidity
- (5) Environment—contamination
- (6) Intense light exposure

6.2.2 The count and characteristics of the particles formed as a result of these stresses will vary in general with the duration of the stress and subsequent storage time and conditions.

6.3 Sources of Intrinsic Particles:

6.3.1 Intrinsic particles may be formed when materials in contact with drug substance or product are stressed, such as the shedding of particles by pumps used in fill and finish operations. In other cases, the stresses may be minimal, but the materials are not verified to be sufficiently particle free; an example would be the shedding of particles from a filter. As with inherent particles, the creation of particles depends both on the duration of particular stresses and the time of storage.

6.4 Combinations of particular stresses may arise in different process steps during manufacturing operations, including:

6.4.1 Formulation,

6.4.2 Sterilization,

6.4.3 Storage: conditions, time of storage, and choice of container,

6.4.4 Transport,

6.4.5 pH adjustments,

6.4.6 ~~Viral Inactivation Steps~~; inactivation steps,

6.4.7 ~~UF/DF~~; Ultrafiltration/diafiltration,

6.4.8 Container or closure siliconization, which may promote aggregation of proteins,

6.4.9 Freeze-thaw,

6.4.10 Mixing, and

6.4.11 ~~Fill/Finish~~; Fill/finish.

6.5 Components in the manufacturing process may contribute particles directly (for example, polymer particles shed by a single use system component or other flexible system components), or may contribute to increased particle load indirectly (for example, protein adsorption and subsequent desorption as a particle from a hydrophobic polymer surface). The use of components and filters requires the development of compatibility profiles with the product and solutions to assure leachable substances are not a concern as discussed in USP <1663> and USP <1664>. The therapeutically active drug substance (small or large molecule) would have to be shown not to bind to the filter system as ~~evidene~~evidenced by loss of potency or any indications of API degradation. Process steps may either increase or decrease particle concentrations, or a combination thereof. For example, filtration will remove inherent particles but may introduce intrinsic particles shed from the filtration media or even promote further growth in inherent particles by nucleating interfacial growth of protein aggregates. ISO 8871 is a guide to the compatibility of rubber or elastomeric components for most aspects of stopper performance testing. In addition, many protein solutions or drug formulation impurities can interact with medical grade silicone used to lubricate the container, closure or plunger, and result in increased protein aggregate formation over time in the absence of surfactant. Also, residual tungsten from the manufacturing of syringe barrels with staked cannulas has been implicated in protein aggregation and particle formation. Pumps are another common source of particles and should be inspected frequently for indicators of wear or particulate generation. Piston pumps can generate stainless steel particles,

peristaltic pumps can cause spallation or abrasion of the inner tubing wall and generate polymeric particles, and diaphragm pumps can generate rubber diaphragm particles over time. Close attention to pump maintenance is recommended.

7. Baseline Monitoring During the Manufacturing Process

7.1 Biopharmaceutical manufacturers should establish baselines for particle levels at key steps in the manufacturing process to evaluate the effects of component changes, process changes and stability on the product. Baseline data should be in place to assess and understand how these changes impact the particle formation during and after the manufacturing process. Particle baselines may be developed during:

- 7.1.1 ~~Formulation Development~~development

- 7.1.2 ~~Clinical Lot Manufacturing~~lot manufacturing

- 7.1.3 ~~Routine Manufacturing~~manufacturing

7.2 Testing should be conducted at time of release and at the conclusion of shelf life in order to assess the formation and change in distribution of subvisible particles over time. Particle data should be collected according to size in the following categories: ~~2–5 µm, 5–10 µm, 10–25 µm, 25–50 µm and 50–100 µm~~ 2 µm to 5 µm, 5 µm to 10 µm, 10 µm to 25 µm, 25 µm to 50 µm, and 50 µm to 100 µm (Options for reporting these data are given in Section ~~1314~~). Changes in quantities or distribution of subvisible particles should be investigated to identify root cause. Manufacturers may consider particle contributions from other process steps and studies, including:

- 7.2.1 ~~Scale-Up~~Scale-up,

- 7.2.2 ~~Freeze/Thaw~~Freeze/thaw studies,

- 7.2.3 Development stability studies,

- 7.2.4 ~~Container/Closure~~Container/closure studies, and

- 7.2.5 ~~Transport/Storage~~Transport/storage studies.

7.3 Monitoring should also be considered during key manufacturing operations, in particular: <https://standards.iteh.ai/astm-e3060-23>

- 7.3.1 Sterilization,

- 7.3.2 Filling,

- 7.3.3 ~~Container/Closure~~Container/closure supplies and use,

- 7.3.4 Marketed ~~Product Stability~~product stability studies,

- 7.3.5 Manufacturing ~~Sites~~site changes, and

- 7.3.6 Manufacturing ~~Device~~device process changes.

7.4 Once the baselines are available, significant deviations from the baseline should be noted and particles should be characterized if possible. This characterization may help identify root cause. Studies should be undertaken to address the sources or adjust the process, or both, to minimize their formation. In addition, the contribution of particles from the external environment during the manufacturing process, particularly during filling operations, should be evaluated, understood and minimized.

7.5 As part of the baseline characterization, it is desirable to identify the dominant subpopulations of particle types. One useful approach is to generate samples with particles of known composition and known mechanism of generation. From these samples, images representing different categories of particle types can be used to generate parameters for filtering of the images to categorize them, based on assessment of risk. Care should be taken in using the PSD of the sample particles to generate size-based filter parameters, since the size of particles in test samples may differ significantly from intentionally created particles. Image distinction

may be straightforward for some common uniform particle types such as silicone oil, whereas distinguishing rare particles such as extrinsic fibers from fibrous protein particles is difficult. Image analysis is a rapid means of identifying particle types, but care in interpretation of images is necessary, especially for irregularly shaped particles. Shape information (for example, aspect ratio, circularity, etc.) and image intensity analysis measurements (for example, average intensity, intensity differences, etc.) may also be included. Accurate morphological analysis may not be possible for particles below 5 μm , depending on the instrument used. Because dynamic imaging does not provide direct chemical information, the specificity of image analysis, especially (but not only) for small particles, cannot equal the specificity of microspectroscopy techniques. While use of Fourier Transform Infrared spectrometry (FTIR) or Raman microspectroscopy and Scanning Electron Microscopy-Energy Dispersive Spectroscopy (SEM-EDS) methods can identify particle types with greater confidence than dynamic image analysis, these methods have greatly reduced throughput and have limitations on minimum particle size or composition. SEM-EDS gives basic elemental composition of both organic and inorganic particles as small as 100 nm, but the method is not appropriate for fragile and highly hydrated protein particles, or similar particles. FTIR and Raman are generally limited to particle sizes greater than $\approx 10 \mu\text{m}$, with greatly reduced throughput and less chemical specificity near the low end of the size range. Positive identification of particles below $\approx 10 \mu\text{m}$ is impractical and in some cases, not will depend on the analysis instrument and method capabilities and in some cases may not be possible. When investigating deviations from process control, dynamic image analysis and investigation by spectroscopic or other chemically specific methods may be warranted.

7.6 Dynamic image analysis provides a highly sensitive method for measuring the particle size and counting the number of particles. Typical limits of detection for dynamic image analysis correspond to very low volume fractions of particles. For example, 200 particles per milliliter at a diameter of 5 μm is equivalent to a volume fraction of only 10^{-8} . As a result, for many common particle types, detection of particles is possible at concentrations far below levels that would impact product quality.

7.7 From the perspective of risk analysis, particles may be categorized as:

7.7.1 Particles that may be present in the final drug product and represent a potentially significant risk to safety or efficacy (for example, aggregated protein, foreign material),

7.7.2 Particles with low intrinsic risk (for example, silicone oil), oil in products intended for IV administration), and

7.7.3 Particles of unknown composition.

8. Apparatus

ASTM E3060-23

8.1 *Principles of Measurement:* <https://standards.iteh.ai/catalog/standards/sist/1d05813a-5389-4f19-b53d-d4323c1ca211/astm-e3060-23>

8.1.1 Dynamic image analysis is a particle analysis technique using light microscopy to examine microscopic particles in a moving fluid. Basic instruments are identical to a standard light microscope, with the difference being that in a Dynamic Image Particle Analyzer the sample fluid is imaged dynamically, while in motion, as opposed to the sample being imaged statically as it is ~~(stationary) with a stationary sample~~ in light microscopy. The primary benefit to dynamic image particle analysis is that since the fluid is being imaged dynamically, larger numbers of particles can be imaged, stored and measured in a short period of time. The larger number of particles analyzed yields much higher levels of statistical confidence versus static microscopy. An additional advantage is that background subtraction to correct for image intensity variations other than particles is very effective, enabling detection of particles with low optical contrast.

8.2 *Basic Hardware Configuration:*

8.2.1 Two distinct configuration types for flow imaging systems are designated here: ~~(+1)~~ stand-alone ~~instrument~~ instruments using a sample obtained from a batch and ~~(+2)~~ in-line configurations whereby a probe containing the system components is inserted into a process vessel or pipe. While this document will concentrate on the stand-alone type of system, since it is the most common (largely because samples are usually drawn from the final drug product in its packaged form), the basic techniques are very similar for the in-line type of technology with the exception that no “sample handling” is involved. Dynamic Image Particle Analyzers (see Fig. 1) consist of ~~3~~ three basic components: fluidics, optics and electronics:

8.2.2 The optics are essentially microscope components, while the electronics consist of the image sensor (camera) and supporting electronics required to obtain and process the digital images of the particles. The fluidic system consists of sample introduction fittings, tubing, a flow cell and a pump. In some systems, samples are introduced into the flow cell by a robotic fluid sampler. The pump can be either peristaltic or syringe type, and may be controlled by the system computer. The fluidics flow is generally as

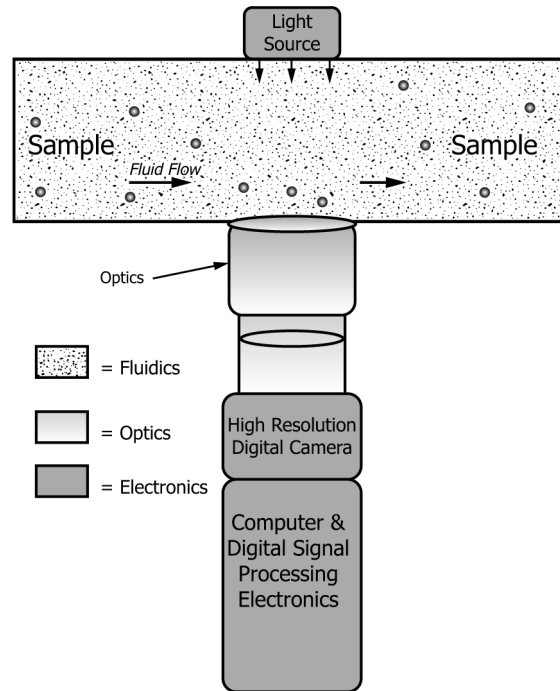

FIG. 1 Components of a Dynamic Imaging Particle Analyzer

follows: the pump (typically located downstream of the flow cell), pulls sample fluid from the sample introduction fittings through the flow cell and out into waste (the sample can be recirculated back to introduction if desired, but generally it only passes through once so that every particle is only imaged once).

8.2.3 For in-line systems, hardware design must be compatible with any cleaning or sterilization requirements of the process.

8.3 Flow Cell/Fluidics:

8.3.1 In stand-alone instruments, the flow cell is a critical system component as it must restrict the position of the particles to lie in an approximate plane perpendicular to the microscope's optical axis in order to keep them in reasonable focus (within the depth of field). The flow cell itself is typically a rectangular piece of material (typically quartz glass) transparent fluid channel (typically glass) with two flat surfaces through which the sample is actually illuminated and imaged. See Fig. 2.

8.3.2 The flow cell is typically designated by the depth as shown in Fig. 2. Different types and configurations of flow cells may be available. In some of these, the width of the flow cell may be greater than the actual camera field of view or illuminated area, while in other configurations the flow width may be restricted to stay inside-of-within or match the camera field of view or

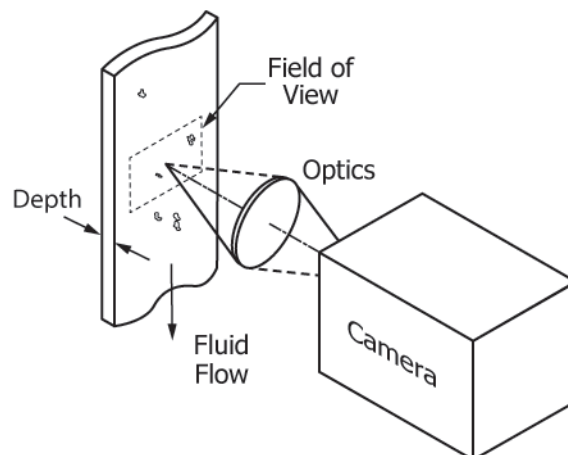

FIG. 2 Flow Cell

illuminated area. In either case, the manufacturer must properly calculate the volume of sample being imaged in order to get valid concentration figures. Because the optical depth of field (area perpendicular to the distance along the optical axis in-between the nearest and farthest objects that are in acceptably sharp focus in the object space) decreases with increasing magnification, it is important to match flow cell depth to optical magnification in the system. While most systems have only a single magnification/flow cell size available, some systems do offer different magnifications; in these systems it is critical that the manufacturer’s recommended flow cell size is matched to the magnification. The choice of flow cell depth also sets an approximate upper limit on the size of particles that may be imaged; particles of sizes close to the flow cell depth or greater may not be properly counted or may cause blockages.

8.4 *In-line Illumination: Imaged Volume and Particle Size Limits:*

8.4.1 The volume of space within the interior of the flow cell where particles are imaged is termed the imaged volume. The imaged volume is defined laterally by the camera view width and height, or by the flow cell width if this is smaller than the camera view width. Similarly, along the optical axis, the depth of the imaged volume is the smaller of the flow cell depth or the optical depth of field. The exact dependence on depth of field is influenced by the threshold values selected which define a particle from its background and the size and degree of optical contrast of the particles. The manufacturer must properly calculate the volume of sample being imaged in order to get valid number concentration values.

8.4.2 The flow cell is typically designated by the volume of space, within the interior of the cell, where particles are imaged. This relies to a great degree on the width, height and depth of the camera view, and may be further restricted by the cell parameters, but also is influenced by the threshold values selected which define a particle from its background. The manufacturer must properly calculate the volume of sample being imaged in order to get valid concentration figures. There are several instrument variants where the imaged volume is defined by the depth of field of the imaging objective, and not by the physical depth of a flow cell. In some cases, the sample passes through a flow cell or flow passage, but the depth of field is substantially smaller than the flow cell depth. In this case, the imaged volume in which particles are detected, and consequently the reported number concentration, may depend on particle type, illumination, and threshold settings. Some systems use a different arrangement to hydrodynamically focus the particles relative to the optics, usually referred to as a sheath flow system. A sheath flow system uses a wide tube of glass through which a tunnel of fluid (sheath fluid) is created for the sample to pass through in the center by varying the velocity and density of the two fluids so that they do not mix. The net result is that the sample particles pass through the imaging zone in a very narrow stream (typically in single file), and thus remain in sharp focus. These systems often have very small measured imaged volume, and concentration determination may have increased uncertainty. Effects of the sheath flow interaction with the product sample are unknown.

8.4.3 Since dynamic imaging systems use light microscopy, the minimum particle size which can be counted is set to approximately 1 μm, or larger for morphological determinations. This is due to diffraction effects and camera pixel size, which create hard limits on the minimum size. Specialized instruments can resolve smaller particles using special optics, but with decreased sample throughput. The maximum size particle that can be measured is typically going to be restricted by flow cell depth: particles larger than the flow cell depth may cause clogging of the flow cell, which is to be avoided. In the case of biopharmaceuticals, where the particles (particularly protein aggregates) may be pliable, some particles larger than the flow cell depth may be seen.

8.5 *Illumination:*

8.5.1 As particles pass through the flow cell, they are illuminated most commonly from behind (“back-lit”, although some systems may use “front lighting”) by a light source, typically a modulated source. The light source is “strobed” (typically at a synchronous interval) in order to capture a blur-free image of the particles as they flow through the cell. Most commonly, the transmitted or reflected light is collected and focused without alteration by filters or polarizers, which is termed brightfield illumination. Some types of particles, such as glass shards, may be challenging to identify with brightfield illumination. Alternate illumination types (for example, darkfield) may provide improved sensitivity in principle, but these alternate illumination schemes may be technically challenging to implement in commercial dynamic imaging particle analyzers.

8.5.2 For in-line systems, all of the above descriptions apply, with the exception that the imaging system is now integral to a pipe or vessel and views the sample therein. The cell, as defined above, still exists for the in-line installation. The illumination configurations available should be the same for the ~~in-line~~ in-line instrument as for the lab instrument in order to allow for the comparison of images and data from both analyses.

8.6 *Data Acquisition and Analysis Software:*

8.6.1 The acquisition and analysis software is an integral part of commercial dynamic imaging systems. Acquisition software controls the sample fluidics, camera settings, and image capture. Software settings are determined during the Method Development process, discussed in Section 9. Analysis software performs the steps discussed in Section 10 and often generates reports automatically. Details of both types of software vary substantially between instruments.

9. Image Processing

9.1 In all imaging systems, the stages of image processing in general can be defined as follows:

9.1.1 *Step 1*—Acquisition of raw gray-scale (or color) image (full camera field of view).

9.1.2 *Step 2*—Reduction of gray-scale or color image to a binary image where each pixel can only have one of two values: particle or not particle.

9.1.3 *Step 3*—Grouping of contiguous particle pixels to form “isolated objects” (individual particles).

9.1.4 *Step 4*—Once each particle is isolated in the binary image, measurements are made and stored for each particle. Measurements may be related to particle morphology or image intensity, as well as particle size.

9.2 *Thresholding and Pixel Grouping (“particle detection”):*

9.2.1 Step 2 above, where the original gray-scale image is converted into a binary image, is one of the most critical steps in the process, and can sometimes produce different results depending on the method used. The most common method used is gray-scale thresholding: in this process, a threshold is chosen. Pixels with an intensity ~~above~~below this threshold are classified as “particle” while those ~~below~~above the threshold are classified as “not particle”. Threshold settings may be fixed by the manufacturer or adjustable. It should be noted that for a mixture of either particle types or sizes that there is no unique threshold that will distinguish the edge of a particle in an identical manner. Note also that the measured particle size depends on the illumination conditions, and as a result the illuminating light level needs careful control. Since most dynamic imaging systems are back-lit, particles will typically have a darker value than the background due to the fact that the particle will obstruct or refract, or both, the light from the illumination source. As a result, most gray-scale methods involve setting a threshold darker than the background; if the intensity value for that pixel is equal to or ~~greater~~less than the threshold value (darker) when compared to the background, then the pixel is considered to be “particle”. The background value for each pixel in the camera array is the value obtained when no particles are present, typically derived by averaging the pixel value over several frames as the fluid is moving through the flow cell. In general, each manufacturer will either pre-set the threshold method/values or supply recommended settings to use. Some systems allow thresholding that selects pixels that are either darker or lighter than the specified threshold. The system must be set up and calibrated per the manufacturer’s recommendations. It is, however, important to understand what thresholding method and values are used because they can affect particle measurements dramatically. The lower size limit for particle detection depends both on the optical resolution of the system and on the pixel size of the camera; this limit is approximately 1 μm for typical dynamic imaging particle analyzers.

9.2.2 In Step 3, once every pixel in the original image has been classified as “particle” or “not particle” by the thresholding process, contiguous groups of pixels classified as “particle” are grouped together to form objects. In this case each stand-alone object is an actual particle in the original image, consisting of one or more touching pixels classified in the binary image as “particle” pixels. This process, referred to as “particle detection”, can be simple (for example, pixels that are touching each other in the binary image), or complex (proprietary algorithms).

9.2.3 The thresholding and particle detection processes also become important when looking at how concentrated a sample can be when being imaged. ~~There is an upper limit for measurement where particles are~~As the number concentration increases, there is an increased likelihood of particles being too crowded together to be separated and counted individually. In a sample with a high particle concentration, two particles in close proximity to each other in the camera image may be interpreted as a single particle. While there are some algorithms available for “declumping” or “de-aggregating” particles, their use is typically limited to particles of known shape, and generally the analyses are too computationally expensive to work in a real time environment. Separation of particles by the use of image analysis software should not be used as particles may be genuinely ~~aggregated~~agglomerated. Commercial dynamic imaging systems in common use for biopharmaceutical applications conform to this recommendation. Refer to 10.4.1 for further discussion.

~~9.2.4 Unfortunately, there is no way to predict a specific concentration number that would become a limit, as it is sample~~