



Designation: C747 – 23

Standard Test Method for Moduli of Elasticity and Fundamental Frequencies of Carbon and Graphite Materials by Sonic Resonance¹

This standard is issued under the fixed designation C747; the number immediately following the designation indicates the year of original adoption or, in the case of revision, the year of last revision. A number in parentheses indicates the year of last reappraisal. A superscript epsilon (ϵ) indicates an editorial change since the last revision or reappraisal.

1. Scope*

1.1 This test method covers determination of the dynamic elastic properties of isotropic and near isotropic carbon and graphite materials at ambient temperatures. Specimens of these materials possess specific mechanical resonant frequencies that are determined by the elastic modulus, mass, and geometry of the test specimen. The dynamic elastic properties of a material can therefore be computed if the geometry, mass, and mechanical resonant frequencies of a suitable (rectangular or cylindrical) test specimen of that material can be measured. Dynamic Young's modulus is determined using the resonant frequency in the flexural or longitudinal mode of vibration. The dynamic shear modulus, or modulus of rigidity, is found using torsional resonant vibrations. Dynamic Young's modulus and dynamic shear modulus are used to compute Poisson's ratio.

1.2 This test method determines elastic properties by measuring the fundamental resonant frequency of test specimens of suitable geometry by exciting them mechanically by a singular elastic strike with an impulse tool. Specimen supports, impulse locations, and signal pick-up points are selected to induce and measure specific modes of the transient vibrations. A transducer (for example, contact accelerometer or non-contacting microphone) senses the resulting mechanical vibrations of the specimen and transforms them into electric signals. (See Fig. 1.) The transient signals are analyzed, and the fundamental resonant frequency is isolated and measured by the signal analyzer, which provides a numerical reading that is (or is proportional to) either the frequency or the period of the specimen vibration. The appropriate fundamental resonant frequencies, dimensions, and mass of the specimen are used to calculate dynamic Young's modulus, dynamic shear modulus, and Poisson's ratio. Annex A1 contains an alternative approach using continuous excitation.

1.3 The values stated in SI units are to be regarded as standard. No other units of measurement are included in this standard.

¹ This test method is under the jurisdiction of ASTM Committee D02 on Petroleum Products, Liquid Fuels, and Lubricants and is the direct responsibility of Subcommittee D02.F0 on Manufactured Carbon and Graphite Products.

Current edition approved Oct. 1, 2023. Published November 2023. Originally approved in 1974. Last previous edition approved in 2016 as C747 – 16. DOI: 10.1520/C0747-23.

1.4 *This standard does not purport to address all of the safety concerns, if any, associated with its use. It is the responsibility of the user of this standard to establish appropriate safety, health, and environmental practices and determine the applicability of regulatory limitations prior to use.*

1.5 *This international standard was developed in accordance with internationally recognized principles on standardization established in the Decision on Principles for the Development of International Standards, Guides and Recommendations issued by the World Trade Organization Technical Barriers to Trade (TBT) Committee.*

2. Referenced Documents

2.1 ASTM Standards:²

- C215 Test Method for Fundamental Transverse, Longitudinal, and Torsional Resonant Frequencies of Concrete Specimens
- C559 Test Method for Bulk Density by Physical Measurements of Manufactured Carbon and Graphite Articles
- C885 Test Method for Young's Modulus of Refractory Shapes by Sonic Resonance
- C1161 Test Method for Flexural Strength of Advanced Ceramics at Ambient Temperature
- D4175 Terminology Relating to Petroleum Products, Liquid Fuels, and Lubricants
- E111 Test Method for Young's Modulus, Tangent Modulus, and Chord Modulus
- E177 Practice for Use of the Terms Precision and Bias in ASTM Test Methods
- E228 Test Method for Linear Thermal Expansion of Solid Materials With a Push-Rod Dilatometer
- E691 Practice for Conducting an Interlaboratory Study to Determine the Precision of a Test Method

3. Terminology

3.1 Definitions:

3.1.1 For definitions of terms used in this test method, refer to Terminology D4175.

² For referenced ASTM standards, visit the ASTM website, www.astm.org, or contact ASTM Customer Service at service@astm.org. For *Annual Book of ASTM Standards* volume information, refer to the standard's Document Summary page on the ASTM website.

*A Summary of Changes section appears at the end of this standard

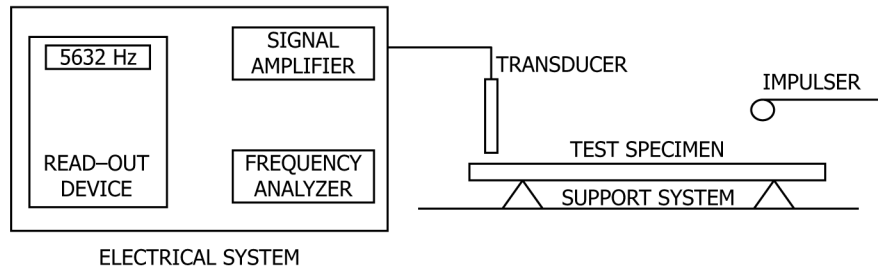

FIG. 1 Block Diagram of Typical Test Apparatus

3.1.2 *antinodes, n*—two or more locations that have local maximum displacements in an unconstrained slender rod or bar in resonance.

3.1.3 *elastic modulus*—the ratio of stress to strain, in the stress range where Hooke’s law is valid.

3.1.4 *flexural vibrations, n*—the vibrations that occur when the displacements in a slender rod or bar are in a plane normal to the length dimension.

3.1.5 *homogeneous, adj*—in carbon and graphite technology, the condition of a specimen such that the composition and density are uniform, so that any smaller specimen taken from the original is representative of the whole. Practically, as long as the geometrical dimensions of the test specimen are large with respect to the size of individual grains, crystals, components, pores, or microcracks, the body can be considered homogeneous.

3.1.6 *in-plane flexure, n*—for rectangular parallelepiped geometries, a flexure mode in which the direction of displacement is in the major plane of the test specimen.

3.1.7 *isotropic, adj*—in carbon and graphite technology, having an isotropy ratio of 0.9 to 1.1 for a specific property of interest.

3.1.8 *longitudinal vibrations*—when the oscillations in a slender rod or bar are in a plane parallel to the length dimension, the vibrations are said to be in the longitudinal mode.

3.1.9 *nodes, n*—one or more locations in a slender rod or bar in resonance having a constant zero displacement. For the fundamental flexural resonance of such a rod or bar, the nodes are located at 0.224 *L* from each end, where *L* is the length of the specimen.

3.1.10 *out-of-plane flexure, n*—for rectangular parallelepiped geometries, a flexure mode in which the direction of displacement is perpendicular to the major plane of the test specimen.

3.1.11 *Poisson’s ratio (μ), n*—the absolute value of the ratio of transverse strain to the corresponding axial strain resulting from uniformly distributed axial stress below the proportional limit of the material. Young’s Modulus (*E*), shear modulus (*G*), and Poisson’s ratio (*μ*) are related by the following equation:

$$\mu = (E / 2 G) - 1 \quad (1)$$

3.1.12 *resonant frequency, n*—naturally occurring frequencies of a body driven into flexural, torsional, or longitudinal vibration that are determined by the elastic modulus, mass, and

dimensions of the body. The lowest resonant frequency in a given vibrational mode is the fundamental resonant frequency of that mode.

3.1.13 *shear modulus, n*—the elastic modulus in shear or torsion, also called modulus of rigidity or torsional modulus.

3.1.14 *torsional vibrations, n*—the vibrations that occur when the oscillations in each cross-sectional plane of a slender rod or bar are such that the plane twists around the length dimension axis.

3.1.15 *transverse vibrations, n*—when the oscillations in a slender rod or bar are in a horizontal plane normal to the length dimension, the vibrations are said to be in the transverse mode; this mode is also commonly referred to as the flexural mode when the oscillations are in a vertical plane.

3.1.16 *Young’s modulus, n*—the elastic modulus in tension or compression.

4. Summary of Test Method

4.1 This test method measures the fundamental resonant frequency of test specimens of suitable geometry (bar or rod) by exciting them mechanically by a singular elastic strike with an impulse tool. A transducer (for example, contact accelerometer or non-contacting microphone) senses the resulting mechanical vibrations of the specimen and transforms them into electric signals. Specimen supports, impulse locations, and signal pick-up points are selected to induce and measure specific modes of the transient vibrations. The signals are analyzed, and the fundamental resonant frequency is isolated and measured by the signal analyzer, which provides a numerical reading that is (or is proportional to) either the frequency or the period of the specimen vibration. The appropriate fundamental resonant frequencies, dimensions, and mass of the specimen are used to calculate dynamic Young’s modulus, dynamic shear modulus, and Poisson’s ratio.

5. Significance and Use

5.1 This test method may be used for material development, characterization, design data generation, and quality control purposes.

5.2 This test method is primarily concerned with the room temperature determination of the dynamic moduli of elasticity and rigidity of slender rods or bars composed of homogeneously distributed carbon or graphite particles.

5.3 This test method can be adapted for other materials that are elastic in their initial stress-strain behavior, as defined in Test Method E111.

5.4 This basic test method can be modified to determine elastic moduli behavior at temperatures from -75°C to $+2500^{\circ}\text{C}$. Thin graphite rods may be used to project the specimen extremities into ambient temperature conditions to provide resonant frequency detection by the use of transducers as described in 7.1.

6. Interferences

6.1 The relationships between resonant frequency and dynamic modulus presented herein are specifically applicable to homogeneous, elastic, isotropic materials.

6.1.1 This method of determining the moduli is applicable to inhomogeneous materials only with careful consideration of the effect of inhomogeneities and anisotropy. The character (volume fraction, size, morphology, distribution, orientation, elastic properties, and interfacial bonding) of inhomogeneities in the specimens will have a direct effect on the elastic properties of the specimen as a whole. These effects must be considered in interpreting the test results for composites and inhomogeneous materials.

6.1.2 The procedure involves measuring transient elastic vibrations. Materials with very high damping capacity may be difficult to measure with this technique if the vibration damps out before the frequency counter can measure the signal (commonly within three to five vibration cycles).

6.1.3 If specific surface treatments (coatings, machining, grinding, etching, etc.) change the elastic properties of the near-surface material, there may be accentuated effects on the properties measured by this flexural method, as compared to static bulk measurements by tensile or compression testing.

6.1.4 The test method is not satisfactory for specimens that have major discontinuities, such as large cracks (internal or surface) or voids.

6.2 This test method for determining moduli is limited to specimens with regular geometries (rectangular parallelepiped and cylinders) for which analytical equations are available to relate geometry, mass, and modulus to the resonant vibration frequencies. The test method is not appropriate for determining the elastic properties of materials that cannot be fabricated into such geometries.

6.2.1 The analytical equations assume parallel and concentric dimensions for the regular geometries of the specimen. Deviations from the specified tolerances for the dimensions of the specimens will change the resonant frequencies and introduce error into the calculations.

6.2.2 Edge treatments such as chamfers or radii are not considered in the analytical equations. Edge chamfers on flexure bars prepared according to Test Method C1161 will change the resonant frequency of the test bars and introduce error into the calculations of the dynamic modulus. It is recommended that specimens for this test method not have chamfered or rounded edges.

6.2.3 For specimens with as-fabricated and rough or uneven surfaces, variations in dimensions can have a significant effect in the calculations. For example, in the calculation of dynamic modulus, the modulus value is inversely proportional to the cube of the thickness. Uniform specimen dimensions and precise measurements are essential for accurate results.

6.3 The test method assumes that the specimen is vibrating freely, with no significant restraint or impediment. Specimen supports should be designed and located properly in accordance with 9.3.1, 9.4.1, and 9.5.1 so the specimen can vibrate freely in the desired mode. In using direct contact transducers, the transducer should be positioned away from antinodes and with minimal force to avoid interference with free vibration. With non-contacting transducers, the maximum sensitivity is accomplished by placing the transducer at an antinode.

6.4 Proper location of the impulse point and transducer is important in introducing and measuring the desired vibration mode. The locations of the impulse point and transducer should not be changed in multiple readings; changes in position may develop and detect alternative vibration modes. In the same manner, the force used in impacting should be consistent in multiple readings.

6.5 If the frequency readings are not repeatable for a specific set of impulse and transducer locations on a specimen, it may be because several different modes of vibration are being developed and detected in the test. The geometry of the test bar and desired vibration mode should be evaluated and used to identify the nodes and antinodes of the desired vibrations. More consistent measurements may be obtained if the impulse point and transducer locations are shifted to induce and measure the single desired mode of vibration.

7. Apparatus

7.1 Apparatus suitable for accurately detecting, analyzing, and measuring the fundamental resonant frequency or period of a vibrating free beam is used. The test apparatus is shown in Fig. 1. It consists of an impulser, a suitable pickup transducer to convert the mechanical vibration into an electrical signal, an electronic system (consisting of a signal conditioner/amplifier, a signal analyzer, and a frequency readout device), and a support system. Commercial instrumentation is available that measures the frequency or period of the vibrating specimen.

7.2 *Impulser*—The exciting impulse is imparted by lightly striking the specimen with a suitable implement. This implement should have most of its mass concentrated at the point of impact and have mass sufficient to induce a measurable mechanical vibration, but not so large as to displace or damage the specimen physically. In practice, the size and geometry of the impulser depends on the size and mass and elastic properties of the specimen and the force needed to produce vibration. For commonly tested geometries (small bars, rods, and discs) in advanced ceramics, an example of such an impulser would be a steel sphere 6 mm in diameter glued to the end of a flexible 10 cm long polymer rod. (See Fig. 2.) An alternative impulser would be a solid metal, ceramic, or polymer sphere (2 mm to 20 mm in diameter) dropped on the specimen through a guide tube to ensure proper impulse position.

7.3 *Signal Pickup*—Signal detection can be via transducers in direct contact with the specimen or by non-contact transducers. Contact transducers are commonly accelerometers using piezoelectric or strain gage methods to measure the vibration. Non-contact transducers are commonly acoustic

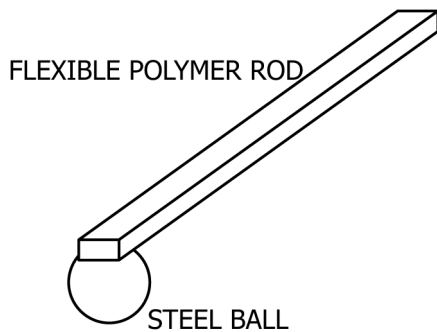

FIG. 2 Diagram of Typical Impulser for Small Specimens

microphones, but they may also use laser, magnetic, or capacitance methods to measure the vibration. The frequency range of the transducer shall be sufficient to measure the expected frequencies of the specimens of interest. A suitable range would be 100 Hz to 50 kHz for most graphite test specimens. (Smaller and stiffer specimens vibrate at higher frequencies.) The frequency response of the transducer across the frequency range of interest shall have a bandwidth of at least 10 % of the maximum measured frequency before -3 dB power loss occurs.

7.4 Electronic System—The electronic system consists of a signal conditioner/amplifier, signal analyzer, and a frequency readout device. The system should have accuracy and precision sufficient to measure the frequencies of interest to an accuracy of 0.1 %. The signal conditioner/amplifier should be suitable to power the transducer and provide an appropriate amplified signal to the signal analyzer. The signal analysis system consists of a frequency counting device and a readout device. Appropriate devices are frequency counter systems with storage capability or digital storage oscilloscopes with a frequency counter module. With the digital storage oscilloscope, a Fourier Transform signal analysis system may be useful for analyzing more complex waveforms and identifying the fundamental resonant frequency.

7.5 Support System—The support shall serve to isolate the specimen from extraneous vibration without restricting the desired mode of specimen vibration. Appropriate materials should be stable at the test temperatures. Support materials can be either soft or rigid for ambient conditions. Examples of soft materials would be a compliant elastomeric material, such as polyurethane foam strips. Such foam strips would have simple flat surfaces for the specimen to rest on. Rigid materials, such as metal or ceramic, should have sharp knife edges or cylindrical surfaces on which the specimen should rest. The rigid supports should be resting on isolation pads to prevent ambient vibrations from being picked up by the transducer. Wire suspension can also be used. Specimens shall be supported along node lines appropriate for the desired vibration in the locations described in Section 9.

8. Test Specimen

8.1 The specimens shall be prepared so that they are either rectangular or circular in cross-section. Either geometry can be used to measure both dynamic Young's modulus and dynamic

shear modulus. Although the equations for computing shear modulus with a cylindrical specimen are both simpler and more accurate than those used with a rectangular bar, experimental difficulties in obtaining torsional resonant frequencies for a cylindrical specimen usually preclude its use for determining shear modulus.

8.2 Resonant frequencies for a given specimen are functions of the specimen dimensions as well as its mass and moduli. Dimensions should therefore be selected with this relationship in mind. The selection of size shall be made so that, for an estimated modulus, the resonant frequencies measured will fall within the range of frequency response of the transducers and electronics used. For a slender rod, the ratio of length to minimum cross-sectional dimension should have a value of at least 5. However, a ratio of approximately 10 to 20 is preferred for ease in exciting the fundamental frequency. For shear modulus measurements of rectangular bars, a ratio of width to thickness of 5 or greater is recommended for minimizing experimental difficulties.

8.3 Deviations from the recommended sample ratio range introduce an elevated level of difficulty in obtaining a recorded measurement for fundamental frequency that can reduce confidence in the results. For this reason, it is recommended that two additional guidelines be employed as allowable in order to increase the likely accuracy of the frequency being recorded:

8.3.1 Determine the fundamental frequency using specimens that are within the recommended length to width ratio of between 5 and 20, or use progressively larger specimens as necessary, in order to establish baseline frequency characteristics of the material being evaluated. The expected value for fundamental frequency of a non-standard specimen can be calculated based upon the measured geometry and the known fundamental frequency of a standard specimen, and any deviation or shift can be appropriately noted.

8.3.2 Spurious vibration modes are more easily discounted if the test is repeated on the same specimen until ten readings are obtained that lie within ± 10 % of the mean. It is acknowledged that for less ideal specimen geometries, the frequency mean that is eventually used for the modulus calculation may require an extended number of measurements until an appropriate group of ten readings is obtained. Operator experience will play a valuable role in the collection of resonant frequency values in non-standard specimen geometries.

8.4 All surfaces on the rectangular specimen shall be flat. Opposite surfaces across the length and width shall be parallel within 0.05 mm or 0.1 %, whichever is greater. Opposite surfaces across the thickness shall be parallel within 0.05 mm or 0.1 %, whichever is greater. The cylindrical specimen shall be round and constant in diameter within 0.05 mm or 0.1 %, whichever is greater.

8.5 Test specimen mass shall be determined within 0.1 % or 10 mg, whichever is greater.

8.6 Test specimen length shall be measured to within 0.025 mm or 0.1 %, whichever is greater. Test specimen cross-sectional dimensions (thickness and width in rectangular beams; diameter in cylindrical rods) shall be measured within

0.1 % or 0.025 mm, whichever is greater, at three equally spaced locations along the length and an average value determined.

8.7 Porous materials and those susceptible to hydration should be dried in air at 120 °C in a drying oven until the mass is constant (less than 0.1 % or 10 mg difference in measured mass with 30 min of additional drying).

8.8 It is recommended that the laboratory obtain and maintain an internal reference specimen with known and recorded fundamental resonant frequencies in flexure and torsion. The reference specimen should be used to check and confirm the operation of the test system on a regular basis. It can also be used to train operators in the proper test setup and test procedure. The reference specimen can be a standard ceramic material (alumina, silicon carbide, zirconia, etc.) or it may be of a similar size, composition, and microstructure to the types of specimens commonly tested at the laboratory. The reference specimen must meet the size, dimensional tolerances, and surface finish requirements of Section 8.

9. Procedure

9.1 Activate all electrical equipment and allow it to stabilize according to the manufacturer’s recommendations.

9.2 Use a test specimen established as a verification/calibration standard to verify the equipment response and accuracy.

9.3 *Fundamental Flexural Resonance Frequency (Out-of-Plane Flexure):*

9.3.1 Place the specimen on the supports located at the fundamental nodal points (0.224 L from each end; see Fig. 3).

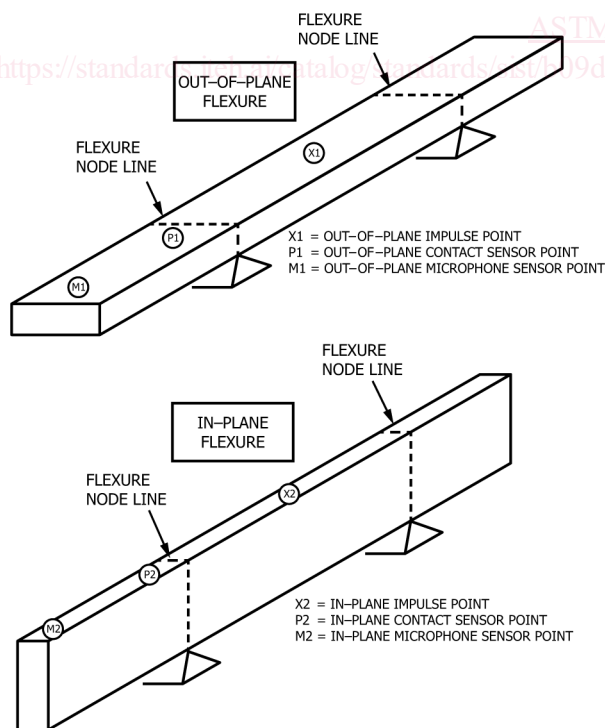

FIG. 3 Rectangular Specimens Tested for In-plane and Out-of-plane Flexure

9.3.2 Determine the direction of maximum sensitivity for the transducer. Orient the transducer so that it will detect the desired vibration.

9.3.2.1 *Direct Contact Transducers*—Place the transducer in contact with the test specimen to pick up the desired vibration. If the transducer is placed at an antinode (location of maximum displacement), it may mass load the specimen and modify the natural vibration. The transducer should preferably be placed only as far from the nodal points as necessary to obtain a reading (see Fig. 3). This location will minimize the damping effect from the contacting transducer. The transducer contact force should be consistent, with good response and minimal interference with the free vibration of the specimen.

9.3.2.2 *Non-Contact Transducers*—Place the non-contact transducer over an antinode point and close enough to the test specimen to pick up the desired vibration, but not so close as to interfere with the free vibration (see Fig. 3).

9.3.3 Strike the specimen lightly and elastically, either at the center of the specimen or at the opposite end of the specimen from the detecting transducer (see Fig. 3).

9.3.4 Record the resultant reading, and repeat the test until a recommended ten readings are obtained that lie within 10 % of the mean. The round-robin interlaboratory study (12.2) showed that data points significantly (>10 %) out of range were measurements of spurious vibration modes or secondary harmonics. If ten readings cannot be taken, a minimum of five readings that lie within 10 % of the mean shall be required for estimating the mean. Use the mean of these readings to determine the fundamental resonant frequency in flexure.

9.4 *Fundamental Flexural Resonance Frequency (In-Plane Flexure):*

9.4.1 This procedure is the same as that above (9.3), except that the direction of vibration is in the major plane of the specimen. Rotate the test bar 90° around its long axis and reposition it on the specimen supports (see Fig. 3). Transpose the width and thickness dimensions in the calculations. For homogeneous, isotropic materials, the calculated moduli should be the same as the moduli calculated from the out-of-plane frequency. The comparison of in-plane and out-of-plane frequency measurements can thus be used as a cross check of experimental methods and calculations.

9.5 *Fundamental Torsional Resonance Frequency:*

9.5.1 Support the specimen at the midpoint of its length and width (the torsional nodal planes) (see Fig. 4).

9.5.2 Locate the transducer at one quadrant of the specimen, preferably at approximately 0.224 L from one end and toward the edge. This location is a nodal point of flexural vibration and will minimize the possibility of detecting a spurious flexural mode (see Fig. 4).

9.5.3 Strike the specimen on the quadrant diagonally opposite the transducer, again at 0.224 L from the end and near the edge. Striking at a flexural nodal point will minimize the possibility of exciting a flexural mode of vibration (see Fig. 4).

9.5.4 Record the resultant reading, and repeat the test until a recommended ten readings are obtained that lie within 10 % of the mean. The round-robin interlaboratory study (12.2) showed that data points significantly (> 10 %) out of range were measurements of spurious vibration modes or secondary

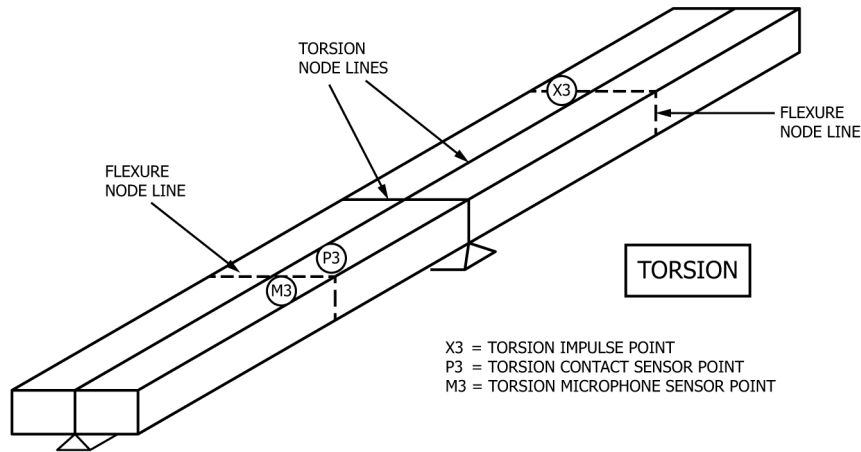

FIG. 4 Rectangular Specimen Tested for Torsional Vibration

harmonics. If ten readings cannot be taken, a minimum of five readings that lie within 10 % of the mean shall be required for estimating the mean. Use the mean of these readings to determine the fundamental resonant frequency in torsion.

9.6 *Longitudinal Fundamental Resonance Frequency*—This procedure is the same as that above (9.3), except that the direction of vibration is longitudinal along the long axis of the specimen. However, the specimen should be supported at locations other than their nodal points, as this will encourage the specimen to vibrate in the flexural mode in addition to the longitudinal mode. Place either a contacting or non-contacting transducer at one end of the specimen and strike the opposite end to induce a vibration parallel to the specimen length. For homogeneous, isotropic materials, the calculated moduli should be the same as the moduli calculated from the in-plane and out-of-plane frequency. A comparison to the in-plane and out-of-plane modulus can thus be used as a cross check of experimental methods and calculations.

10. Calculation

10.1 Dynamic Young's Modulus^{3,4}:

10.1.1 For the fundamental flexure frequency of a rectangular bar,

$$E = 0.9464(mf_f^2 / b)(L^3 / t^3)T_1 \quad (2)$$

where:

- E = Young's modulus, Pa,
- m = mass of the bar, g (see Note 2),
- b = width of the bar, mm (see Note 1 and Note 2),
- L = length of the bar, mm, (see Note 2),

³ Spinner, S., Reichard, T. W., and Tefft, W. E., "A Comparison of Experimental and Theoretical Relations Between Young's Modulus and the Flexural and Longitudinal Resonance Frequencies of Uniform Bars," *Journal of Research of the National Bureau of Standards-A. Physics and Chemistry*, Vol 64A, No. 2, March-April, 1960.

⁴ Spinner, S., and Tefft, W. E., "A Method for Determining Mechanical Resonance Frequencies and for Calculating Elastic Moduli from These Frequencies," *Proceedings, ASTM*, 1961, pp. 1221-1238.

- t = thickness of the bar, mm (see Note 1 and Note 2),
- μ = Poisson's Ratio,
- f_f = fundamental resonant frequency of bar in flexure, Hz, and
- T_1 = correction factor for fundamental flexural mode to account for finite thickness of bar, Poisson's ratio, and other factors.

$$T_1 = 1 + 6.585(1 + 0.0752\mu + 0.8109\mu^2)\left(\frac{t}{L}\right)^2 - 0.868\left(\frac{t}{L}\right)^4 - \left[\frac{8.340(1 + 0.2023\mu + 2.173\mu^2)\left(\frac{t}{L}\right)^4}{1.000 + 6.338(1 + 0.1408\mu + 1.536\mu^2)\left(\frac{t}{L}\right)^2} \right] \quad (3)$$

NOTE 1—The width (b) and thickness (t) values used in the modulus calculations (Eq 2 and Eq 3) for the rectangular specimens will depend on the type of vibration (out-of-plane or in-plane) induced in the specimen. The cross-sectional dimension t will always be parallel to the vibrational motion. The dimension b will always be perpendicular to the vibrational motion. In effect, the two different flexural modes will give two different fundamental resonant frequencies, but the calculations for the two modes should give the same modulus value, because the values for b and t are exchanged in the calculations for the two different flexure modes.

NOTE 2—In the modulus equations, the mass and length terms are given in units of grams and millimeters. However, the defined equations can also be used with mass and length terms in units of kilograms and meters with no changes in terms or exponents.

10.1.1.1 If $L/t \geq 10$, T_1 can be simplified to the following:

$$T_1 = 1.000 + 6.585(t/L)^2 \quad (4)$$

and E can be calculated directly.

10.1.1.2 If $L/t < 10$ and Poisson's ratio is known, then T_1 can be calculated directly from Eq 3 and then used to calculate E .

10.1.1.3 If $L/t < 10$ and Poisson's ratio is not known, then an initial Poisson's ratio must be assumed to begin the computations. An iterative process is then used to determine a value of Poisson's ratio, based on experimental Young's modulus and shear modulus. The iterative process is illustrated by the flowchart in Fig. 5 and described in (1) through (5) below.