



Designation: D5508 – 23

Standard Test Method for Determination of Residual Acrylonitrile Monomer in Styrene-Acrylonitrile Copolymer Resins and Nitrile-Butadiene Rubber by Headspace-Capillary Gas Chromatography (HS-CGC)¹

This standard is issued under the fixed designation D5508; the number immediately following the designation indicates the year of original adoption or, in the case of revision, the year of last revision. A number in parentheses indicates the year of last reappraisal. A superscript epsilon (ϵ) indicates an editorial change since the last revision or reappraisal.

1. Scope*

1.1 This test method covers the determination of the residual acrylonitrile (RAN) content in nitrile-butadiene rubbers (NBR), styrene-acrylonitrile (SAN) copolymers, and rubber-modified acrylonitrile-butadiene-styrene (ABS) resins.

1.2 Any components that can generate acrylonitrile in the headspace procedure will constitute an interference. The presence of 3-hydroxypropionitrile in latices limits this procedure to dry rubbers and resins.

1.3 The values stated in SI units are to be regarded as standard. No other units of measurement are included in this standard.

1.4 *This standard does not purport to address all of the safety concerns, if any, associated with its use. It is the responsibility of the user of this standard to establish appropriate safety, health, and environmental practices and determine the applicability of regulatory limitations prior to use.* Specific precautionary statements are given in 6.3 and 6.4.

NOTE 1—There is no known ISO equivalent to this standard.

1.5 *This international standard was developed in accordance with internationally recognized principles on standardization established in the Decision on Principles for the Development of International Standards, Guides and Recommendations issued by the World Trade Organization Technical Barriers to Trade (TBT) Committee.*

2. Referenced Documents

2.1 *ASTM Standards:*²

D883 [Terminology Relating to Plastics](#)

¹ This test method is under the jurisdiction of ASTM Committee D20 on Plastics and is the direct responsibility of Subcommittee D20.70 on Analytical Methods.

Current edition approved Oct. 1, 2023. Published October 2023. Originally approved in 1994. Last previous edition approved in 2016 as D5508 - 16. DOI: 10.1520/D5508-23.

² For referenced ASTM standards, visit the ASTM website, www.astm.org, or contact ASTM Customer Service at service@astm.org. For *Annual Book of ASTM Standards* volume information, refer to the standard's Document Summary page on the ASTM website.

E456 [Terminology Relating to Quality and Statistics](#)
E691 [Practice for Conducting an Interlaboratory Study to Determine the Precision of a Test Method](#)
E2935 [Practice for Evaluating Equivalence of Two Testing Processes](#)

3. Summary of Test Method

3.1 Two dispersions (in o-dichlorobenzene) are prepared and sealed in headspace vials for each polymer; one vial contains the polymer in solvent while the second vial contains the polymer, solvent, plus a known standard addition of acrylonitrile (AN). Both vials are agitated for a specified time under ambient conditions. After agitation, the vials are thermally equilibrated in a constant-temperature bath.

3.2 After completion of the timed equilibration, an aliquot of the heated headspace gas from each vial is injected into a capillary gas-chromatographic column using an automated injection system. The capillary column will provide the chromatographic resolution necessary to isolate the AN from other volatiles potentially present. The AN response is measured using a nitrogen-specific detector (NPD). The raw data signal is converted to a relative RAN concentration through a standard addition calculation.

4. Significance and Use

4.1 A measurement of the residual acrylonitrile in nitrile rubbers (NBR), styrene-acrylonitrile copolymers or ABS terpolymers will determine the polymer's suitability for various applications.

4.2 Under optimum conditions, the minimum level of detection of RAN in NBR, SAN, or ABS terpolymers is approximately 50 ppb.

5. Apparatus

5.1 *Gas Chromatograph*, equipped with a nitrogen-phosphorus specific detector, backflush valve (see Fig. 1), split injector, and capable of accepting megabore (0.53 mm inside diameter) fused silica capillary columns. Detector make-up gas is required.

*A Summary of Changes section appears at the end of this standard

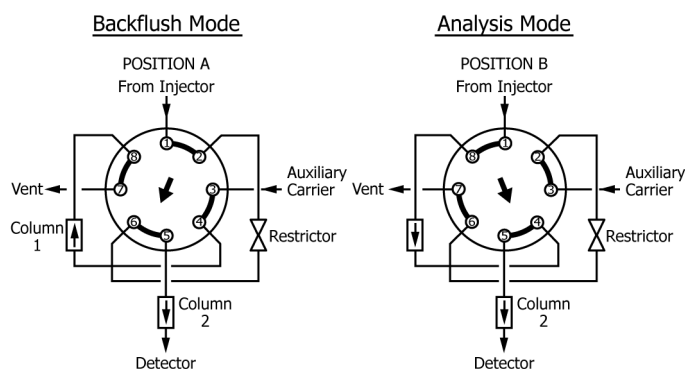

FIG. 1 Configuration of Eight-Port Valve Backflush Assembly

NOTE 2—The use of a backflush configuration will provide for operating advantages, but its use is optional. Chlorinated solvents quench the alkali bead in a nitrogen-phosphorous detector, producing a loss of signal. While the bead (signal) will recover as the solvent evacuates the detector, repeated quenching during a multi-run sequence may produce instabilities in the signal (and precision) over the sequence period.

5.2 *Automated Headspace Sampler*, shall have a thermostatted sample tray capable of 90°C heating with constant heating times. Automated sampling of the headspace gas in the sample vials via a heated, constant-volume sample loop or pressure balancing sampling mechanism is required. Conduct sampling to the gas chromatograph by means of a heated transfer line of minimum dead volume.

5.3 *Fused Silica Porous-Layer-Open-Tubular (PLOT) Capillary Column*, 30 m × 0.53 mm inside diameter.

NOTE 3—The column should be cut so as to have a 3 m section for the pre-column (Column 1) and a 27-m section for the analytical column (Column 2).

5.4 *Variable Restrictor*.

5.5 *Data-Recording Device*—A strip-chart recorder, recording integrator, or computer-based data system is suitable.

5.6 *Wrist-Action Shaker*.

5.7 *Analytical Balance*, 0.1-mg readability.

5.8 *Headspace Vials*, 20-mL capacity.

5.9 *Aluminum Crimp Caps*, 20-mm diameter.

5.10 *Septa*, TFE-fluorocarbon-faced silicone construction, 20-mm diameter.

5.11 *Crimper*, for 20-mm crimp caps.

6. Reagents and Materials

6.1 *Purity of Reagents*—Chemicals of the highest purity shall be used in all tests. Solvents shall have a minimum of volatile impurities. Other grades shall only be used after ascertaining that the reagent is free of interferences.

6.2 Observe all health and safety recommendations for each chemical, as prescribed by the manufacturer.

6.3 *Acrylonitrile*, 99 + %. (**Warning**—Acrylonitrile is an OSHA-regulated carcinogen and should not be released into the laboratory atmosphere. All work involving acrylonitrile should be carried out in a hood or with proper personal protection to minimize human exposure.)

6.4 *o-Dichlorobenzene*. (**Warning**—*o*-Dichlorobenzene is moderately toxic and should only be handled in a hood or with proper personal protection to limit human exposure.)

NOTE 4—Each lot of *o*-dichlorobenzene should be analyzed under the same instrumental conditions as the NBR samples to ensure that impurities are not present that will interfere with the acrylonitrile peak.

7. Sampling and Storage

7.1 The polymer test unit (sample) submitted for analysis shall be supplied in the form of a 1³/₄ in. (45 mm) cube.

7.2 All test specimens shall be taken from the interior of the polymer-test unit to minimize the contribution of surface effects on the residual-acrylonitrile level.

7.3 Keep all polymer-test units in sealed containers. Analyze test-specimen solutions immediately after preparation. Report any analysis delays along with the test results.

8. Calibration

8.1 *Preparation of External Standard Solutions*:

8.1.1 Tare (to the nearest 0.1 mg) a 25-mL volumetric flask containing 10 mL of *o*-dichlorobenzene (DCB).

8.1.2 Weigh (to the nearest 0.1 mg) into the 25-mL volumetric flask 40 ± 5 mg of AN. Dilute to the mark with DCB. Label this solution as the “external-standard master solution”.

8.1.3 Add 1 mL of the “external-standard master solution” to a clean 10-mL volumetric flask containing 2 mL of DCB. Dilute to the mark with additional DCB. Label this solution as the “external-standard working solution”.

8.1.4 Prepare fresh “master” and “working” solutions each week and keep refrigerated at 4°C using Parafilm “M” to seal volumetric stoppers.

8.2 *Generation of the External-Standard Calibration Curve*: 6b-986d-1c9a2b224695/astm-d5508-23

NOTE 5—A new external-standard calibration curve should be generated each week to account for any changes in the AN response due to NPД bead fluctuations.

8.2.1 Transfer 5 mL of DCB into seven clean headspace vials, using a volumetric pipet.

8.2.2 Add 0 (solvent blank), 1, 5, 10, 20, 60, or 100 μL of the “external-standard working solution”, respectively, to the vials.

8.2.3 Seal each vial immediately after addition with a septum and crimp cap.

8.2.4 Establish the instrument parameters as listed in Annex A1.

8.2.5 Obtain the peak-area values for AN in each of the standards.

9. Procedure

9.1 *Determine the Target AN Weight for Polymer Test Units*:

9.1.1 Weigh (to the nearest 0.1 mg) into a clean headspace vial 400 ± 10 mg of polymer. Add 5 mL of DCB, using a volumetric pipet. Seal vial with septum and crimp cap.

9.1.2 Place the vial on a wrist-action shaker, set at maximum agitation for 16 h under ambient conditions.