



Designation: D8079 – 23

Standard Practice for Preparation of Compacted Slab Asphalt Mix Samples Using a Segmented Rolling Compactor¹

This standard is issued under the fixed designation D8079; the number immediately following the designation indicates the year of original adoption or, in the case of revision, the year of last revision. A number in parentheses indicates the year of last reapproval. A superscript epsilon (ϵ) indicates an editorial change since the last revision or reapproval.

1. Scope

1.1 This practice covers the fabrication of slabs of asphalt mix using an automated laboratory rolling compactor (RC). Compacted specimens are suitable for volumetric and physical property testing. This practice should not be used for acceptance or rejection of a material or for purchasing purposes.

1.2 *Units*—The values stated in SI units are to be regarded as standard. No other units of measurement are included in this standard.

1.3 The text of this standard references notes and footnotes which provide explanatory material. These notes and footnotes (excluding those in tables and figures) shall not be considered as requirements of the standard.

1.4 *This standard does not purport to address all of the safety concerns, if any, associated with its use. It is the responsibility of the user of this standard to establish appropriate safety, health, and environmental practices and determine the applicability of regulatory limitations prior to use.*

1.5 *This international standard was developed in accordance with internationally recognized principles on standardization established in the Decision on Principles for the Development of International Standards, Guides and Recommendations issued by the World Trade Organization Technical Barriers to Trade (TBT) Committee.*

2. Referenced Documents

2.1 ASTM Standards:²

[D8 Terminology Relating to Materials for Roads and Pavements](#)

[D1188/D1188M Test Method for Bulk Specific Gravity and Density of Compacted Asphalt Mixtures Using Coated Samples](#)

¹ This practice is under the jurisdiction of ASTM Committee D04 on Road and Paving Materials and is the direct responsibility of Subcommittee D04.20 on Mechanical Tests of Asphalt Mixtures.

Current edition approved Nov. 1, 2023. Published November 2023. Originally approved in 2016. Last previous edition approved in 2016 as D8079 – 16. DOI: 10.1520/D8079-23.

² For referenced ASTM standards, visit the ASTM website, www.astm.org, or contact ASTM Customer Service at service@astm.org. For *Annual Book of ASTM Standards* volume information, refer to the standard's Document Summary page on the ASTM website.

[D2041/D2041M Test Method for Theoretical Maximum Specific Gravity and Density of Asphalt Mixtures](#)

[D2726/D2726M Test Method for Bulk Specific Gravity and Density of Non-Absorptive Compacted Asphalt Mixtures](#)

[D3666 Specification for Minimum Requirements for Agencies Testing and Inspecting Road and Paving Materials](#)

[D6752/D6752M Test Method for Bulk Specific Gravity and Density of Compacted Asphalt Mixtures Using Automatic Vacuum Sealing Method](#)

[D6857/D6857M Test Method for Maximum Specific Gravity and Density of Asphalt Mixtures Using Automatic Vacuum Sealing Method](#)

[D7460 Test Method for Determining Fatigue Failure of Compacted Asphalt Concrete Subjected to Repeated Flexural Bending \(Withdrawn 2019\)³](#)

[D8237 Test Method for Determining Fatigue Failure of Asphalt-Aggregate Mixtures with the Four-Point Beam Fatigue Device](#)

[E644 Test Methods for Testing Industrial Resistance Thermometers](#)

2.2 AASHTO Standards:⁴

[AASHTO T 321 Method of Test for Determining the Fatigue Life of Compacted Asphalt Mixtures Subjected to Repeated Flexural Bending](#)

[AASHTO T 324 Method of Test for Hamburg Wheel-Track Testing of Compacted Hot Mix Asphalt \(HMA\)](#)

3. Terminology

3.1 For definitions of terms used in this standard, refer to Terminology D8.

4. Summary of Practice

4.1 A sample of loose asphalt mix is compacted in an automatic apparatus by the combination of vertical displacements of a segmented rolling compactor foot and horizontal

³ The last approved version of this historical standard is referenced on www.astm.org.

⁴ Available from American Association of State Highway and Transportation Officials (AASHTO), 444 N. Capitol St., NW, Suite 249, Washington, DC 20001, <http://www.transportation.org>.

movements of a rolling compactor foot relative to the compactor tray to produce a slab of compacted asphalt with a target theoretical density (that is, based on the geometric volume of the specimen).

5. Significance and Use

5.1 Asphalt slabs compacted with the rolling compactor can be used to obtain specimens for further testing, including bulk specific gravity following Test Methods D1188/D1188M, D2726/D2726M, and D6752/D6752M, fatigue performance characteristics following Test Methods D7460 and D8237 or AASHTO T 321, and Hamburg wheel-track testing following AASHTO T 324.

5.2 Specimens to perform other standard tests could also be obtained, as long as their volume is contained within the volume of a slab.

NOTE 1—The quality of the results produced by this standard are dependent on the competence of the personnel performing the procedure and the capability, calibration, and maintenance of the equipment used. Agencies that meet the criteria of Specification D3666 are generally considered capable of competent and objective testing, sampling, inspection, etc. Users of this practice are cautioned that compliance with Specification D3666 alone does not completely ensure reliable results. Reliable results depend on many factors; following the suggestions of Specification D3666 or some similar acceptable guideline that provides a means of evaluating and controlling some of those factors.

6. Apparatus

6.1 *Segmented Rolling Compactor*—A compactor capable of fabricating asphalt slabs comprised of the following system components: (1) reaction frame, (2) fully integrated loading system, including loading rams, controller, and data acquisition to record loads applied, height measurements, and number of cycles, and (3) segmented rolling compactor foot and mold. The compactor must comply with the following specifications:

6.1.1 Vertical load divided by the width of the mold perpendicular to the rolling direction is adjustable by the user up to at least 75 kg/cm.

NOTE 2—The vertical load should be measured and controlled to an accuracy of ±5 % of the applied load. The loading system used to achieve the required load can be electromechanical, pneumatic, or hydraulic.

6.1.2 The capability to perform at least four load cycles every minute.

6.1.3 The compactor must be capable of producing compacted slabs with minimum dimensions of 300 ± 5 mm long, 260 ± 5 mm wide, and with a minimum height measured at the center of the slab of 38 mm.

6.1.4 The controller must also be capable of automatically terminating the compaction run after meeting one of three termination criteria: sample height, number of loading cycles, or target density. The controller shall state that the compaction is finished and the termination criterion (height, cycles, or theoretical density) shall be recorded.

NOTE 3—Since the dimensions of the mold and the mass of the mixture are known, the theoretical density can be calculated.

6.1.5 The reaction frame shall be rigid and capable of sustaining the maximum forces generated during the compaction process. It shall also be able to sustain the reaction forces being applied to the mold.

6.1.6 The loading system (see Fig. 1) shall consist of a controlled vertical axis loading system capable of applying a compressive load to the mix during compaction. The system shall be able to control the height of the rolling compactor foot using displacement or vertical load. The system can use lever arms, electric motors, pneumatics, hydraulics, or a combination thereof to control the height or load of the rolling compactor foot.

6.1.7 The machine shall be designed such that the rolling compactor foot movement ensures constant distance between the foot and bottom of the mold along each cycle.

6.2 *Mold Plates*—Wear plates used on top and bottom of the specimen and rolling compactor foot. All mold plates and the rolling compactor foot shall be fabricated from metal strong enough to withstand the applied forces. The mold bottom plate shall be flat (<0.5 mm over 300 mm).

6.3 *Thermometer*—A platinum resistance thermometer (PRT), thermocouple, or dial-type thermometer with a range of at least 10 °C to 232 °C. Calibrate the thermometer system (probe and readout) in accordance with Test Methods E644. Corrections shall be applied to ensure accurate measurements within ±3 °C.

6.4 *Balance*—At least one balance with a minimum capacity of 8000 g, with a sensitivity of 0.1 g.

6.5 *Oven*—At least one forced draft oven, capable of heating the asphalt binder, aggregates, and equipment to the compaction temperature specified by the asphalt binder manufacturer, and thermostatically controlled to ±3 °C. If short-term oven

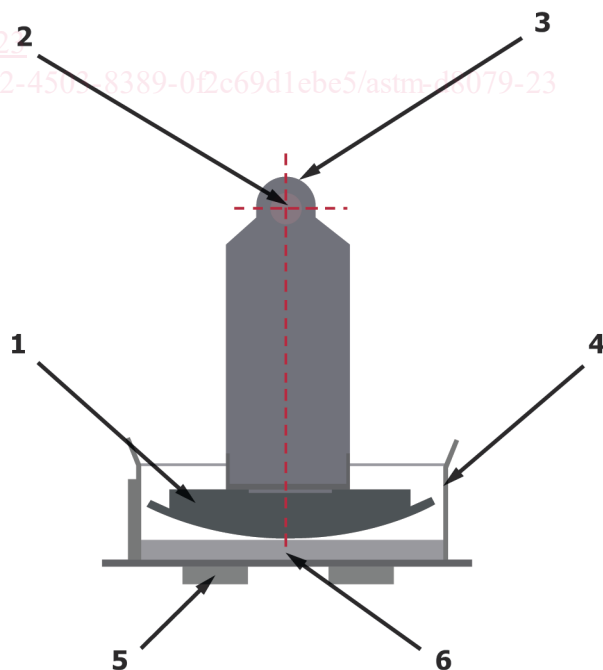

- 1. Rolling compactor foot
- 2. Pivot
- 3. Linear loading point
- 4. Mold
- 5. Rolling compactor tray
- 6. Sample

FIG. 1 Example Schematic of a Rolling Compactor