



Designation: ~~E953/E953M~~—16 E953 – 23

Standard Practice ~~Test Method~~ for Fusibility of Refuse-Derived Fuel (RDF) Ash¹

This standard is issued under the fixed designation ~~E953/E953M~~;E953; the number immediately following the designation indicates the year of original adoption or, in the case of revision, the year of last revision. A number in parentheses indicates the year of last reappraisal. A superscript epsilon (ϵ) indicates an editorial change since the last revision or reappraisal.

1. ~~Scope~~

1.1 This practice covers the observation of the temperatures at which triangular pyramids (cones) prepared from RDF ash attain and pass through certain stages of fusing and flow when heated at a specific rate in controlled, mildly-reducing, and oxidizing atmospheres.

1.2 The test method is empirical, and strict observance of the requirements and conditions is necessary to obtain reproducible temperatures and enable different laboratories to obtain concordant results.

1.3 The values stated in either SI units or inch-pound units are to be regarded separately as standard. The values stated in each system may not be exact equivalents; therefore, each system shall be used independently of the other. Combining values from the two systems may result in non-conformance with the standard.

1.4 *This standard does not purport to address all of the safety problems, if any, associated with its use. It is the responsibility of the user of this standard to establish appropriate safety and health practices and determine the applicability of regulatory limitations prior to use.*

1.5 *This international standard was developed in accordance with internationally recognized principles on standardization established in the Decision on Principles for the Development of International Standards, Guides and Recommendations issued by the World Trade Organization Technical Barriers to Trade (TBT) Committee.*

<https://standards.iteh.ai/catalog/standards/sist/4abf124a-4cd1-42c6-8b22-02e1971faa5b/astm-e953-23>

2. Referenced Documents

2.1 ~~ASTM Standards:~~²

~~D5681 Terminology for Waste and Waste Management~~

~~E829 Practice for Preparing Refuse-Derived Fuel (RDF) Laboratory Samples for Analysis~~

3. Terminology

3.1 ~~Definitions and Symbols~~—The critical temperature points to be observed are as follows, denoting the atmosphere used:

3.2 ~~initial deformation temperature, IT~~—the temperature at which the first rounding of the apex of the cone occurs. Shrinking or warping of the cone is ignored if the tip remains sharp. In Fig. 1, the first cone shown is an unheated one; the second cone, IT, is a typical cone at the initial deformation stage.

¹ This practice-test method is under the jurisdiction of ASTM Committee D34 on Waste Management and is the direct responsibility of Subcommittee D34.03 on Treatment, Recovery and Reuse.

Current edition approved Nov. 15, 2016/Nov. 1, 2023. Published November 2016/November 2023. Originally approved in 1983. Last previous edition approved in 2008/2016 as E953/E953M—08/E953/E953M – 16. DOI: 10.1520/E0953-E0953M-16.10.1520/E0953-23.

² For referenced ASTM standards, visit the ASTM website, www.astm.org, or contact ASTM Customer Service at service@astm.org. For Annual Book of ASTM Standards volume information, refer to the standard's Document Summary page on the ASTM website.

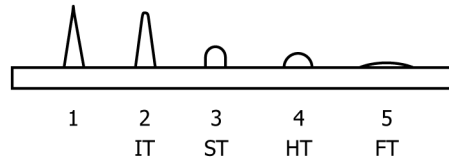

FIG. 1 Critical Temperature Points

3.3 *softening temperature, ST*—the temperature at which the cone has fused down to a spherical lump in which the height is equal to the width at the base as shown by the third cone, ST, in Fig. 1.

3.4 *hemispherical temperature, HT*—the temperature at which the cone has fused down to a hemispherical lump at which point the height is one half the width of the base as shown by the fourth cone, HT, in Fig. 1.

3.5 *fluid temperature, FT*—the temperature at which the fused mass has spread out in a nearly flat layer with a maximum height of 1.6 mm [$1/16$ in.] as shown in the fifth cone, FT, in Fig. 1.

3.6 For definitions of additional terms used in this test method, refer to Terminology D5681.

4. Significance and Use

4.1 The standard is available to producers and users of RDF to use in determining the fusibility of ash produced from RDF.

4.2 *Limitations of Ash Fusibility Data*—Ash fusibility data are too often over-interpreted. In practice, types of burning equipment, rate of burning, temperature and thickness of fire bed or ball, distribution of ash forming mineral matter in the RDF, and viscosity of the molten ash may influence ash behavior more than the ash fusibility characteristics determined by the laboratory test. Furthermore, conditions existing during applied combustion of RDF are so complex that they are impossible to duplicate completely in a small-scale laboratory test. Therefore, the analysis should be considered an empirical one and the data, at best, only qualitative.

5. Apparatus

5.1 *Furnace*—Any gas-fired or electric furnace conforming to the following requirements may be used.

5.1.1 The furnace shall be capable of maintaining a uniform temperature zone in which to heat the ash cones. This zone shall be such that the difference in the melting point of 12.7 mm [$1/2$ in.] pieces of pure gold wire when mounted in place of the ash cones on the cone support shall be not greater than 11°C [20°F] in a reducing atmosphere test run.

5.1.2 The furnace shall be capable of maintaining the desired atmosphere surrounding the cones during heating. The composition of the atmosphere, reducing or oxidizing, shall be maintained within the limits specified in Section 6. The desired atmosphere in the gas-fired furnace surrounding the cones shall be obtained by regulation of the ratio of gas to air in the combustion mixture. The desired atmosphere in the electric furnace shall be obtained by means of gases introduced into the heating chamber. The muffle shall be gas-impervious, free from cracks, and the closure-plug tight fitting. Since state-of-the-art furnaces vary somewhat in design, the gas supply inlet tube shall be installed per instructions of furnace manufacturer.

5.1.3 The furnace shall be capable of regulation so that the rate of temperature rise shall be $8 \pm 3^{\circ}\text{C}$ [$15 \pm 5^{\circ}\text{F}$] per minute.

5.1.4 The furnace shall provide a means of observing the ash cones during the heating. Observation shall be on the same horizontal plane as the cone-support surface.

5.2 *Cone Mold*—A commercially available cone mold as shown in Fig. 2 shall be used. The cone shall be 19 mm [$3/4$ in.] in height and 6.4 mm [$1/4$ in.] in width at each side of the base which is an equilateral triangle.

5.2.1 A steel spatula with a pointed tip, ground off to fit the cone depression in the mold, is suitable for removal of the ash cone.

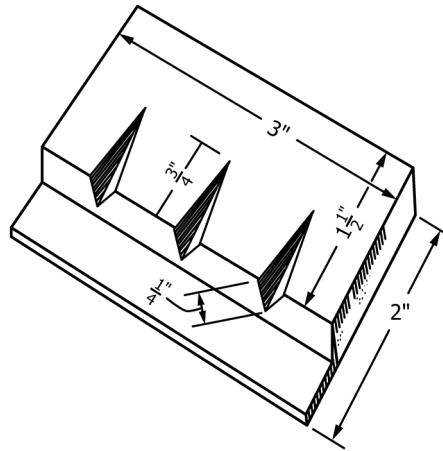

Inch-pound Units, in.	SI Units, mm
1/4	6.4
3/4	19.1
1 1/2	38.1
2	50.2
3	76.2

SI Units, mm	Inch-pound Units, in.
6.4	1/4
19.1	3/4
38.1	1 1/2
50.2	2
76.2	3

FIG. 2 Brass Cone Mold

5.3 *Optical Pyrometer or Thermocouple*, for temperature measurements, conforming to the following requirements:

5.3.1 *Optical Pyrometer*—An optical pyrometer of the disappearing filament type shall be used. The instrument shall have been calibrated to be accurate within 11°C [20°F] up to 1400°C [2550°F] and within 16°C [30°F] from 1400 to 1600°C [2550°F to 2900°F] (Note 1). The pyrometer filament shall be sighted on the cones until the softening point temperature (Fig. 1) has been passed, and then sighted on the cone support. The pyrometer shall have readable graduations not larger than 5.5°C [10°F].

Note 1—The pyrometer equipment shall be standardized periodically by a suitably equipped standardizing laboratory such as that of the National Bureau of Standards, or checked periodically against equipment certified by the National Bureau of Standards.

5.3.2 *Thermocouple*—A thermocouple of platinum and platinum-rhodium, protected from the furnace gases by a glazed porcelain sheath, shall be used with a high-resistance millivoltmeter or potentiometer accurate and readable to within 5.5°C [10°F]. The sheath shall be sealed to the furnace wall by alundum cement. The hot junction of the thermocouple shall touch the end of the sheath and shall be located in the center of the muffle and immediately to the rear of the cones. The thermocouple protective sheath shall be checked periodically for cracks. The thermocouple and its meter shall meet the requirements of Section 9. The potentiometer or millivoltmeter shall be located or shielded adequately as to prevent radiant or convection heating of the cold junction. The room temperature compensator shall be adjusted to the existing temperature.

5.4 *Ash-Cone Refractory Support*—The ash cone shall be mounted on a refractory base composed of a mixture of equal parts by weight of kaolin and alumina conforming to the following requirements:

5.4.1 *Kaolin*—NF-Grade powder passing a 75-µm [No. 200] sieve.

5.4.2 *Aluminum Oxide*—Reagent grade powder passing a 150-µm [No. 100] sieve.

5.5 *Refractory Support Mold*—A mold with flat top and bottom surfaces to provide a refractory support of suitable thickness to

minimize warping shall be used. A side mold not over 6.4 mm [$\frac{1}{4}$ in.] high of any convenient shape, placed on an iron plate so that the top surface of the refractory mix can be struck off flat and parallel to the base by means of a straightedge, is satisfactory. For electric furnace use, legs not over 3 mm [$\frac{1}{8}$ in.] long may be provided on the corners of the cone support by suitable holes bored in the iron base plate of the mold.

5.6 *Gold Wire*,³ twenty-four gage or larger round wire of 99.98 % purity, but drawn from metal of 99.99 % purity, and having a melting point of 1063°C [1945°F].

5.7 *Nickel Wire*,⁴ twenty-four gage or larger round wire of CP nickel 99.98 % pure, fully annealed, and having a melting point of 1452°C [2645°F].

6. Test Atmosphere⁵

6.1 Gas Fired Furnace:

6.1.1 *Reducing Atmosphere Test*—A mildly reducing atmosphere surrounding the cones shall be maintained during the test in the gas-fired furnace. Hydrogen, hydrocarbons, and carbon monoxide shall be considered as reducing gases; oxygen, carbon dioxide, and water vapor shall be considered as oxidizing gases. Nitrogen is inert. The ratio by volume of reducing gases to oxidizing gases in the atmosphere shall be between the limits of 20 to 80 %, that is, on a nitrogen-free basis, the total amount of reducing gases present shall be between the limits of 20 and 80 volume %. A flame 150 to 200 mm [6 to 8 in.] in height and tinged with yellow above the furnace outlet has been found to provide an atmosphere within the specified limits.

6.1.2 *Oxidizing Atmosphere Test*—An atmosphere containing a minimum amount of reducing gases shall be maintained surrounding the cones during the test in the gas-fired furnace. On a nitrogen-free basis, the volume of the reducing gases present in the atmosphere will not exceed 10 volume %. Combustion with the maximum possible quantity of air with preservation of the specified rate of temperature increase has been found to provide an atmosphere within the specified limits. A completely blue flame, not over 50 mm [2 in.] in height above the outlet at the beginning of the test, provides the desired atmosphere; and, by regulation of the combustion gas-air ratio, the specified atmosphere and temperature rise can be maintained.

6.2 Electric Furnace:

6.2.1 *Reducing Atmosphere Test*—A regulated flow of gas of the nominal composition, 60 % carbon monoxide and 40 \pm 5 volume % carbon dioxide, shall be maintained in the heating chamber throughout the test in the electric furnace. The gas stream shall be regulated by any convenient means to provide a measured flow of 1.3 to 1.5 furnace volumes per minute.

6.2.2 *Oxidizing Atmosphere Test*—A regulated stream of air shall be maintained throughout the test in the electric furnace. The gas stream shall be regulated by any convenient means to provide a measured flow of 1.3 to 1.5 furnace volumes per minute.

7. Preparation of Ash

7.1 Use RDF milled to passing a 0.5-mm [0.02-in.] sieve prepared in accordance with Practice E829 to obtain the ash by incineration in a well-ventilated muffle furnace. The quantity of RDF required will vary with the ash content; usually 3 to 5 g of ash will suffice for cones for several check determinations. Spread out the analysis sample of RDF in a layer approximately 6.4 mm [$\frac{1}{4}$ in.] in depth in a fireclay or porcelain roasting dish. Place the dish in the muffle at a low temperature, and gradually heat to redness at such a rate as to avoid mechanical loss from too rapid expulsion of volatile matter. The rate of temperature rise of 500°C [932°F] in 1 h was found to be satisfactory. Complete the conversion to ash at a temperature of 800 to 900°C [1470 to 1650°F]. Transfer the ash to an agate mortar (Note 2), and grind so it will pass a No. 200 [0.074 mm] sieve.

NOTE 2—A mechanical agate mortar grinder will save time where many determinations are made. An iron mortar or pestle is not recommended because of metallic contamination.

7.2 Spread the ash in a thin layer in a fireclay, silica, or porcelain dish and ignite it in a stream of oxygen for 1½ h at 800 to 850°C [1470 to 1560°F] to ensure complete and uniform oxidation of the ash. Any tube or muffle-type furnace which, when supplied with an oxygen flow of not less than one furnace volume in 5 min will maintain a highly oxidizing atmosphere, is suitable.

³ For information concerning the effect of various atmospheres, see U.S. Bureau of Mines Bulletin 129, 1918.

Note 3—It has been found that in most samples, the initial ignition outlined in 7.1 is sufficient to convert the RDF to ash and the re-ignition step in 7.2 is not necessary. Re-ignition of the ash should be made only if an observable amount of noncombustible matter or carbon is present.

8. Preparation of Cones

8.1 Thoroughly mix the ignited ash in a mechanical mixer or on a sheet of glazed paper or oil cloth by raising first one corner to roll the ash over, and then raising each of the other corners in rotation in the same manner until each corner has been raised five times or more.

8.2 Take sufficient ash for the number of cones desired from various parts of the bulk ash. Moisten the ash with a few drops of a clear, filtered (if necessary) 10 % solution of dextrin containing 0.1 % salicylic acid as a preservative, and work it into a stiff plastic mass with a spatula. Press the plastic material firmly with a spatula into the cone mold to form the triangular pyramids. Strike off the exposed surfaces of the material smooth and remove the cones from the mold by applying pressure at the base with a suitably pointed spatula. Previous coating of the mold with a thin layer of petroleum jelly, thinned with kerosine (if necessary); aids in preventing adherence of the cones to the mold and in providing the sharp point and edges desired in the cone.

8.3 Place the cones in a suitable location to dry sufficiently to permit handling without deformation. Mount the dried cone vertically on a freshly prepared refractory base. Moisten a portion of the well-mixed kaolin-alumina mixture with a minimum amount of water to make a workable, but stiff, plastic mass and firmly press it into the support mold. Strike off the surface of the mass flat and smooth with a steel spatula, moistening with one or two drops of water is necessary to obtain a smooth surface. A number of cones may be mounted on one base. Make shallow triangular depressions, not over 0.8 mm [$\frac{1}{32}$ in.] in depth, with a triangular file ground to the correct size to produce a depression to fit the base of the cone, and locate the cones sufficiently distant from adjacent cones so that no merging of the fusing material of the cones shall occur during the test. Mount the cones vertically in the depressions while the base is still wet without the use of ash or refractory as mounting aid.

Note 4—The intent of the triangular depression is to enable the cones to be mounted in a sufficiently stable manner to permit handling of the prepared support with cones.

Note 5—Gold wires can be mounted on each cone support beside the ash cones, and the gold melting point observed concurrently with the ash cones in both oxidizing and reducing atmospheres.

8.4 For the calibration check run of Section 9, mount 12.7 mm [$\frac{1}{2}$ in.] lengths of gold and nickel wire as described in 5.6 and 5.7 vertically on a support similar to those prepared as described in 8.3, but on which no ash cones are mounted. Insert the pieces of wire into the support before drying. Two or more pieces of each kind of wire should be mounted on this support in locations which correspond to ash cone positions. Dry the support as described in 8.5 but do not ignite. At least one such support with mounted pieces of gold and nickel wire shall be prepared for each week of observation of ash fusibility.

8.5 Dry the mounted cones at 110°C [230°F], and ignite at 750°C [1382°F] to remove all carbonaceous material.

9. Calibration

9.1 At least once during each week of operation, check the optical pyrometer or the thermocouple and its meter for calibration in place under routine test conditions with the reducing atmosphere by observing the melting point of gold. At the same time, check the adequacy of the furnace atmosphere by observing the melting point of nickel.

9.1.1 Insert a support with mounted pieces of gold and nickel wire into the test furnace. Locate at the position used for tests of ash cones.

9.1.2 Establish the reducing gas atmosphere, and heat the furnace chamber in accordance with 10.1.

9.1.3 Observe the temperatures shown on the meter when the pieces of wire melt.

9.1.4 The indicated melting points should be within 5.5°C [10°F] of the following:

Gold	1063°C [1945°F]
Nickel	1452°C [2645°F]

9.1.5 If the indicated melting point of gold wire frequently falls outside of the desired range, readjust or calibrate the meter so that the average temperature from several observations of the gold melting point is within the specified range.

9.1.6 If the indicated melting point for nickel wire frequently falls outside the desired range after applying the corrections in 9.1.5, the consistency of indicated temperatures and the subsequent appearance of the specimen should be examined closely. Erratic readings of failures to obtain melting at 1452°C [2645°F] can be due to nickel oxidation caused by an insufficient reducing atmosphere. If a consistent error of more than 14°C [25°F] is found, the furnace atmosphere and the temperature measurement equipment should be suspected of having faults; necessary corrections should be made.

10. Procedure

10.1 Reducing Atmosphere Test:

10.1.1 Place the mounted test cones in the furnace at a temperature of not over 800°C [1470°F] for the gas-fired furnace and not over 400°C [750°F] for the electric furnace in order to provide sufficient time to purge the air from the uniform temperature zone and establish the desired atmosphere.

10.1.2 If the furnace temperature is below the respective temperature specified in 10.1.1, raise it rapidly to the specified temperature; then control the rate of heating to give a rate of temperature increase of $8 \pm 3^\circ\text{C}$ [$15 \pm 5^\circ\text{F}$] per minute. Maintain this rate throughout the test.

10.1.3 Establish the mildly reducing atmosphere surrounding the cones, as specified in 6.1.1 and 6.2.1, at the temperature specified in 10.1.1 for the respective furnace type. Maintain this atmosphere throughout the test.

Note 6—At temperatures of the order of 1370 to 1430°C [2500 to 2600°F] and above in the gas-fired furnace, it may not be possible to maintain the reducing gases above the 20-volume % limit specified while also preserving the specified rate of temperature increase. At such temperatures, the effect of the atmosphere is not so critical as the maintenance of the specified heating rate. Make every effort to maintain the reducing gases as near the 20-volume % level as possible at such temperature.

10.2 Oxidizing Atmosphere Test:

10.2.1 Place the mounted test cones in the furnace at a temperature of not over 800°C [1470°F] for the gas-fired furnace, and not over 400°C [750°F] for the electric furnace. If the furnace temperature is below the respective temperature specified, raise it rapidly to the specified temperature, then control the rate of heating to give a rate of temperature increase of $8 \pm 3^\circ\text{C}$ [$15 \pm 5^\circ\text{F}$] per minute. Maintain this rate throughout the test.

10.2.2 Establish the oxidizing atmosphere surrounding the cones, as specified in 6.1.2 and 6.2.2 at the temperature specified in 10.2.1 for the respective furnace type. Maintain this atmosphere throughout the test.

11. Report

11.1 Report the following information:

11.1.1 Type of atmosphere;

11.1.2 Initial deformation temperature, IT;

11.1.3 Softening temperature, ST;

11.1.4 Hemispherical temperature, HT, and

11.1.5 Fluid temperature, FT.

12. Precision and Bias

12.1 Due to the lack of any known RDF ash standard, generation of a precision and bias statement for this practice is not feasible.