



Designation: B820 – 23

Standard Test Method for Bend Test for Determining the Formability of Copper and Copper Alloy Strip¹

This standard is issued under the fixed designation B820; the number immediately following the designation indicates the year of original adoption or, in the case of revision, the year of last revision. A number in parentheses indicates the year of last reapproval. A superscript epsilon (ϵ) indicates an editorial change since the last revision or reapproval.

1. Scope*

1.1 This test method covers the technique of bend testing copper and copper alloy strip samples to determine product formability or the ability to resist cracking when forming a bend around a specific radius. The criterion for failure is the occurrence of cracks on the convex surface of the bend.

1.2 This bend test is limited to strip from 0.003 in. to and including 0.031 in. (0.076 mm to and including 0.79 mm) thick.

1.3 The forming or punch radius for the bend test shall be determined by agreement between the manufacturer or supplier and purchaser. This punch radius is typically equal to or greater than the minimum bend radius without failure for the alloy, temper and thickness combination of the strip being tested.

1.4 *Units*—The values stated in inch-pound units are to be regarded as standard. The values given in parentheses are mathematical conversions to SI units which are provided for information only and are not considered standard.

1.5 *This standard does not purport to address all of the safety concerns, if any, associated with its use. It is the responsibility of the user of this standard to establish appropriate safety, health, and environmental practices and determine the applicability of regulatory limitations prior to use.*

1.6 *This international standard was developed in accordance with internationally recognized principles on standardization established in the Decision on Principles for the Development of International Standards, Guides and Recommendations issued by the World Trade Organization Technical Barriers to Trade (TBT) Committee.*

¹ This test method is under the jurisdiction of ASTM Committee B05 on Copper and Copper Alloys and is the direct responsibility of Subcommittee B05.06 on Methods of Test.

Current edition approved Nov. 1, 2023. Published November 2023. Originally approved in 1992. Last previous edition approved in 2018 as B820 – 18. DOI: 10.1520/B0820-23.

2. Referenced Documents

2.1 *ASTM Standards*:²

B846 Terminology for Copper and Copper Alloys

E6 Terminology Relating to Methods of Mechanical Testing

E290 Test Methods for Bend Testing of Material for Ductility

3. Terminology

3.1 For definitions of terms related to copper and copper alloys, refer to Terminology B846.

3.2 For definitions of terms related to mechanical testing, refer to Terminology E6.

3.3 *Definitions of Terms Specific to This Standard:*

3.3.1 *bend, longitudinal (or good way bend)*—a bend with an axis perpendicular to the direction of rolling, drawing, or extrusion (see Fig. 1).

3.3.2 *bend, transverse (or bad way bend)*—a bend with an axis on a plane parallel to the direction of rolling, drawing, or extrusion (see Fig. 1).

NOTE 1—The usage of these two terms is consistent with Test Methods E290.

4. Summary of Test Method

4.1 The bend test is made by applying a force transversely to the length of the specimen in the portion being bent, usually at mid-length. The 90° bending forces are applied through an arrangement illustrated in Fig. 2, while 180° bending forces are applied through an arrangement illustrated in Fig. 3. When complete fracture does not occur, the convex surface of the specimen is examined for cracks. In general, the test using a 180° bend angle is a more severe test than the test using a 90° bend angle.

5. Significance and Use

5.1 This bend test provides information as to the formability or the ability of copper and copper alloy strip to resist cracking when being formed.

² For referenced ASTM standards, visit the ASTM website, www.astm.org, or contact ASTM Customer Service at service@astm.org. For *Annual Book of ASTM Standards* volume information, refer to the standard's Document Summary page on the ASTM website.

*A Summary of Changes section appears at the end of this standard

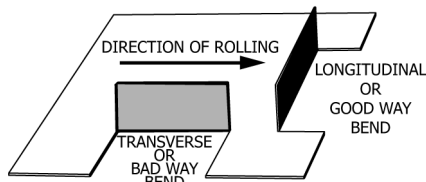

FIG. 1 Direction of Bending

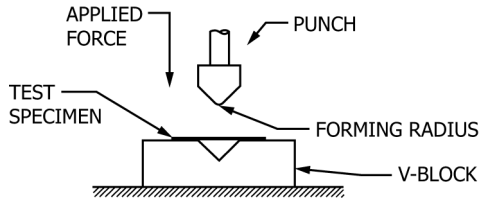

FIG. 2 V-Block and Punch for 90° Bend Test

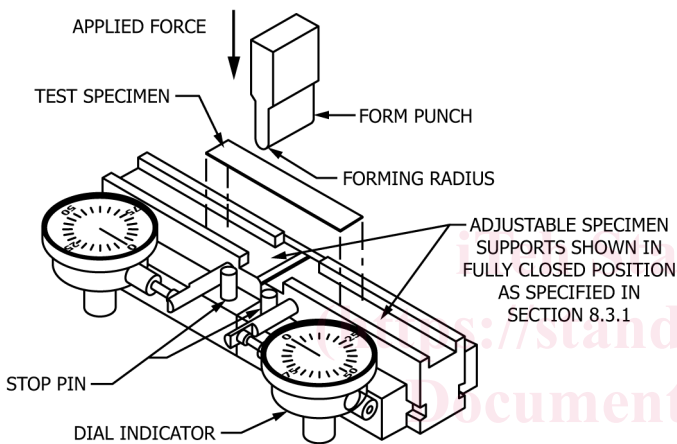

FIG. 3 Fixture for 180° Bend Test

5.2 This test method can be used as a quality control tool to determine if material will form to a given radius.

5.3 This test method is also useful in research and development to provide data for use in selecting a spring material that will safely form to the geometry of a given part.

5.3.1 The forming characteristic of interest is the smallest bend radius that can be formed without cracks or otherwise unacceptable surface conditions (8.4). This radius, R, is the radius of curvature of the nose of the punch used in the test.

5.3.2 In addition, the difference between the angle of the bend after testing and 90° provides a measure of post-forming springback.

5.4 The results are suitable for direct application in design and manufacturing, only when all factors such as the geometry of the part, punch and die design, lubrication, stamping speed, and other material properties are known.

6. Apparatus

6.1 Various devices are suitable for 90° or 180° bend testing. The apparatus shall provide these features:

6.1.1 90° Bend Test Fixture—An illustration of this test fixture is shown in Fig. 2. A specimen rests on a 90° V-block

die. A punch of a given bend radius applies the bending force at the specimen mid-length.

6.1.2 180° Bend Test Fixture—An illustration of this test fixture is shown in Fig. 3. A specimen rests on a pair of pins, rollers, or radiused flat supports. A pin, mandrel, or 180° punch of a given bend radius applies the bending force at the specimen mid-length. Dial indicators with a precision of 0.0005 in. (0.013 mm) or better are necessary to accurately position the two supports.

6.1.2.1 To prevent breaking the punch, it is recommended not to use a radius smaller than ½ the thickness of the material being tested.

6.2 The radius of the pin, mandrel, or punch applying the bend force at the mid-length shall differ not more than ±5 % from the nominal value of the radius.

6.3 The length of all pins, rolls, mandrels, and radius flats must exceed the width of the specimen; they must be strong enough and sufficiently rigid to resist significant deformation.

7. Test Specimens

7.1 Four test specimens shall be required, two in the longitudinal and two in the transverse directions for the 90° and 180° tests.

7.2 The specimen may be prepared by cutting, shearing, or stamping.

7.3 The specimen thickness shall be measured using a micrometer with a precision of 0.0001 in. (0.00254 mm) or higher.

7.4 The specimen length be any convenient length greater than ½ in. (12.7 mm) unless specified otherwise by the purchaser.

7.4.1 In a longitudinal specimen, its length shall be parallel to the direction of rolling as indicated in Fig. 1.

7.4.2 In a transverse specimen, its length shall be perpendicular to the direction of rolling as indicated in Fig. 1.

NOTE 2—The bending characteristics of a metal vary with the orientation of the bends to the direction of rolling. A longitudinal bend will typically take a sharper bend radius than a transverse bend. This characteristic becomes more pronounced as the metal thickness increases.

7.5 The specimen width shall be ½ in. ± ⅛ in. (12.7 mm ± 1.57 mm) unless otherwise agreed upon between the manufacturer or supplier and purchaser.

7.5.1 When the purchaser requires a specimen width less than or equal to ¼ in. (6.35 mm) the producer can optionally apply the narrow width specimen as defined in 7.5.1.1 (see Fig. 4).

7.5.1.1 The narrow width specimen consists of four beams: 0.024 in. ± 0.002 in. (0.6 mm ± 0.05 mm), 0.047 in. ± 0.003 in. (1.2 mm ± 0.08 mm), 0.095 in. ± 0.004 in. (2.4 mm ± 0.1 mm), and 0.189 in. ± 0.005 in. (4.8 mm ± 0.13 mm). Four test specimens shall be required, two in the longitudinal and two in the transverse directions, for the 90° and 180° angles.

7.5.1.2 When the purchaser does not identify a specific width in the narrow width specimen, acceptance or rejection shall be based upon results of analysis of the 0.095 in. ± 0.004 in. (2.4 mm ± 0.1 mm) specimen.