



Standard Practice for Full-Scale Oxygen Consumption Calorimetry Fire Tests¹

This standard is issued under the fixed designation E2067; the number immediately following the designation indicates the year of original adoption or, in the case of revision, the year of last revision. A number in parentheses indicates the year of last reapproval. A superscript epsilon (ϵ) indicates an editorial change since the last revision or reapproval.

1. Scope*

1.1 This practice deals with methods to construct, calibrate, and use full scale oxygen consumption calorimeters to help minimize testing result discrepancies between laboratories.

1.2 The methodology described herein is used in a number of ASTM test methods, in a variety of unstandardized test methods, and for research purposes. This practice will facilitate coordination of generic requirements, which are not specific to the item under test.

1.3 The principal fire-test-response characteristics obtained from the test methods using this technique are those associated with heat release from the specimens tested, as a function of time. Other fire-test-response characteristics also are determined.

1.4 This practice is intended to apply to the conduction of different types of tests, including both some in which the objective is to assess the comparative fire performance of products releasing low amounts of heat or smoke and some in which the objective is to assess whether flashover will occur.

1.5 This practice does not provide pass/fail criteria that can be used as a regulatory tool, nor does it describe a test method for any material or product.

1.6 For use of the SI system of units in referee decisions, see [IEEE/ASTM SI-10](#). The units given in parentheses are provided for information only.

1.7 This standard is used to measure and describe the response of materials, products, or assemblies to heat and flame under controlled conditions, but does not by itself incorporate all factors required for fire hazard or fire risk assessment of the materials, products, or assemblies under actual fire conditions.

NOTE 1—This is the standard caveat described in section F2.2.2.1 of the Form and Style for ASTM Standards manual for fire-test-response standards. In actual fact, this practice does not provide quantitative measures.

¹ This practice is under the jurisdiction of ASTM Committee E05 on Fire Standards and is the direct responsibility of Subcommittee E05.21 on Smoke and Combustion Products.

Current edition approved Nov. 1, 2023. Published November 2023. Originally approved in 2000. Last previous edition approved in 2022 as E2067 – 22. DOI: 10.1520/E2067-23.

1.8 Fire testing of products and materials is inherently hazardous, and adequate safeguards for personnel and property shall be employed in conducting these tests. Fire testing involves hazardous materials, operations, and equipment. See also Section 7.

1.9 *This standard does not purport to address all of the safety concerns, if any, associated with its use. It is the responsibility of the user of this standard to establish appropriate safety, health, and environmental practices and determine the applicability of regulatory limitations prior to use.*

1.10 *This international standard was developed in accordance with internationally recognized principles on standardization established in the Decision on Principles for the Development of International Standards, Guides and Recommendations issued by the World Trade Organization Technical Barriers to Trade (TBT) Committee.*

2. Referenced Documents

2.1 ASTM Standards:²

- [D5424 Test Method for Smoke Obscuration of Insulating Materials Contained in Electrical or Optical Fiber Cables When Burning in a Vertical Cable Tray Configuration](#)
- [D5537 Test Method for Heat Release, Flame Spread, Smoke Obscuration, and Mass Loss Testing of Insulating Materials Contained in Electrical or Optical Fiber Cables When Burning in a Vertical Cable Tray Configuration](#)
- [D6113 Test Method for Using Cone Calorimeter to Determine Fire-Test-Response Characteristics of Insulating Materials Contained in Electrical or Optical Fiber Cables](#)
- [E84 Test Method for Surface Burning Characteristics of Building Materials](#)
- [E176 Terminology of Fire Standards](#)
- [E603 Guide for Room Fire Experiments](#)
- [E906/E906M Test Method for Heat and Visible Smoke Release Rates for Materials and Products Using a Thermopile Method](#)
- [E1354 Test Method for Heat and Visible Smoke Release Rates for Materials and Products Using an Oxygen Consumption Calorimeter](#)

² For referenced ASTM standards, visit the ASTM website, www.astm.org, or contact ASTM Customer Service at service@astm.org. For Annual Book of ASTM Standards volume information, refer to the standard's Document Summary page on the ASTM website.

*A Summary of Changes section appears at the end of this standard

E1474 Test Method for Determining the Heat Release Rate of Upholstered Furniture and Mattress Components or Composites Using a Bench Scale Oxygen Consumption Calorimeter

E1537 Test Method for Fire Testing of Upholstered Furniture

E1590 Test Method for Fire Testing of Mattresses

E1623 Test Method for Determination of Fire and Thermal Parameters of Materials, Products, and Systems Using an Intermediate Scale Calorimeter (ICAL)

E1740 Test Method for Determining the Heat Release Rate and Other Fire-Test-Response Characteristics of Wall Covering or Ceiling Covering Composites Using a Cone Calorimeter

E1822 Test Method for Fire Testing of Stacked Chairs

E2965 Test Method for Determination of Low Levels of Heat Release Rate for Materials and Products Using an Oxygen Consumption Calorimeter

IEEE/ASTM SI-10 International System of Units (SI) The Modernized Metric System

2.2 ISO Standards:³

ISO 13943 Fire Safety-Vocabulary

ISO 5660-1 Fire Tests—Reaction to Fire—Rate of Heat Release from Building Products (Cone Calorimeter Method)

ISO 9705 Fire Tests - Full-Scale Room Test for Surface Products

2.3 California Bureau of Home Furnishings and Thermal Insulation Standards:⁴

CA Technical Bulletin 129 (October 1992), Flammability Test Procedure for Mattresses for Use in Public Buildings

CA Technical Bulletin 133 (January 1991), Flammability Test Procedure for Seating Furniture for Use in Public Occupancies

2.4 NFPA Standards:⁵

NFPA 265 Standard Methods of Fire Tests for Evaluating Room Fire Growth Contribution of Textile Wall Coverings

NFPA 266 Standard Method of Test for Fire Characteristics of Upholstered Furniture Exposed to Flaming Ignition Source – Withdrawn

NFPA 267 Standard Method of Test for Fire Characteristics of Mattresses and Bedding Assemblies Exposed to Flaming Ignition Source – Withdrawn

NFPA 286 Standard Methods of Fire Tests for Evaluating Room Fire Growth Contribution of Wall and Ceiling Interior Finish

NFPA 289 Standard Method of Fire Test for Individual Fuel Packages

2.5 UL Standards:⁶

UL 1685 Standard Vertical Tray Fire Propagation and Smoke Release Test for Electrical and Optical Fiber Cables

UL 1975 Standard Fire Tests for Foamed Plastics Used for Decorative Purposes

3. Terminology

3.1 Definitions:

3.1.1 For definitions of terms used in this practice, refer to Terminology **E176** and ISO 13943. In case of conflict, the definitions given in Terminology **E176** shall prevail.

3.1.2 *continuous* (as related to data acquisition in large-scale tests), *adj*—conducted at data collection intervals of 6 s or less. **(E176)**

3.1.3 *heat release rate, n*—the heat evolved from the specimen, per unit of time. **(E176)**

3.1.4 *ignition, n*—the initiation of combustion. **(E176)**

3.1.4.1 *Discussion*—The combustion may be evidenced by glow, flame, detonation or explosion. The combustion may be sustained or transient.

3.1.5 *oxygen consumption principle, n*—the expression of the relationship between the mass of oxygen consumed during combustion and the heat released. **(E176)**

3.1.6 *smoke, n*—the airborne solid and liquid particulates and gases evolved when a material undergoes pyrolysis or combustion. **(E176)**

3.1.7 *smoke obscuration, n*—reduction of light transmission by smoke, as measured by light attenuation. **(E176)**

3.2 Definitions of Terms Specific to This Standard:

3.2.1 *sample, n*—an amount of the material, product, or assembly, to be tested, which is representative of the item as a whole.

3.2.2 *specimen, n*—representative piece of the product, which is to be tested together with any substrate or treatment.

4. Significance and Use

4.1 The oxygen consumption principle, used for the measurements described here, is based on the observation that, generally, the net heat of combustion is directly related to the amount of oxygen required for combustion (**1**).⁷ Approximately 13.1 MJ of heat are released per 1 kg of oxygen consumed. Test specimens in the test are burned in ambient air conditions, while being subjected to a prescribed external heating source.

4.1.1 This technique is not appropriate for use on its own when the combustible fuel is an oxidizer or an explosive agent, which release oxygen. Further analysis is required in such cases (see **Appendix X2**).

4.2 The heat release is determined by the measurement of the oxygen consumption, as determined by the oxygen concentration and the flow rate in the combustion product stream, in a full scale environment.

³ Available from International Organization for Standardization (ISO), 1, ch. de la Voie-Creuse, Case postale 56, CH-1211, Geneva 20, Switzerland, <http://www.iso.ch>.

⁴ Available from California Bureau of Home Furnishings and Thermal Insulation, State of California, Department of Consumer Affairs, 3485 Orange Grove Avenue, North Highlands, CA 95660-5595.

⁵ Available from National Fire Protection Association (NFPA), 1 Batterymarch Park, Quincy, MA 02169-7471, <http://www.nfpa.org>.

⁶ Available from Underwriters Laboratories (UL), 333 Pfingsten Rd., Northbrook, IL 60062-2096, <http://www.ul.com>.

⁷ The boldface numbers in parentheses refers to the list of references at the end of this standard.

4.3 The primary measurements are oxygen concentration and exhaust gas flow rate. Additional measurements include the specimen ignitability, the smoke obscuration generated, the specimen mass loss rate, the effective heat of combustion and the yields of combustion products from the test specimen.

4.4 The oxygen consumption technique is used in different types of test methods. Intermediate scale (Test Method E1623, UL 1975) and full scale (Test Method D5424, Test Method D5537, Test Method E1537, Test Method E1590, Test Method E1822, ISO 9705, NFPA 265, NFPA 266, NFPA 267, NFPA 286, UL 1685) test methods, as well as unstandardized room scale experiments following Guide E603, using this technique involve a large instrumented exhaust hood, where oxygen concentration is measured, either standing alone or positioned outside a doorway. A large test specimen is placed either under the hood or inside the room. This practice is intended to address issues associated with equipment requiring a large instrumented hood and not stand-alone test apparatuses with small test specimens.

4.4.1 Small scale test methods using this technique, such as Test Methods D6113, E1354, E1474 and E1740, as well as ISO 5660 internationally, are based on a stand-alone apparatus, wherein a small specimen is tested within the equipment. A small-scale test using oxygen consumption calorimetry with a larger test specimen (than the above referenced test methods) and intended for low levels of heat release is Test Method E2965.

4.4.2 Another small scale heat release test method, Test Method E906/E906M, does not use the oxygen consumption technique.

4.4.3 Annex A1 contains the considerations needed for heat release measurements and Annex A2 contains the corresponding measurement equations as well as the equations for smoke and gas release measurements. These equations apply to Test Methods D5424, D5537, E1537, E1590, E1623, and E1822. See also Section 14.

4.5 Throughout this practice, test equipment is referenced to provide helpful guidance to test facilities. Substitution of equivalent, or better, test measuring devices is permissible.

5. Test Room Layout

5.1 Standard Rooms:

5.1.1 Three standard room configurations have been in common use for many years, often designated as the “ASTM”/ “ISO” room (cited in Guide E603 and in ISO 9705), and the “California” room (used in CAT B 129 and CAT B 133, as well as, Test Methods E1537, E1590, and E1822), and the cable tray test room (used in Test Methods D5424 and D5537, as well as, in UL 1685).

5.1.2 *ASTM/ISO Room*—The test room shall have interior dimensions of 2.44 m ± 25 mm by 3.66 m ± 25 mm by 2.44 m ± 25 mm high (8 ft by 12 ft by 8 ft high). The room shall have no openings other than a doorway opening 0.76 m ± 6 mm by 2.03 m ± 6 mm (30 in. by 80 in.), located as indicated in Fig. 1, and other small openings, as necessary to make test measurements. Construct the test room of wooden or metal studs, and line it with gypsum wallboard, Type X, or calcium silicate wallboard. Position a hood (see Section 6) outside of

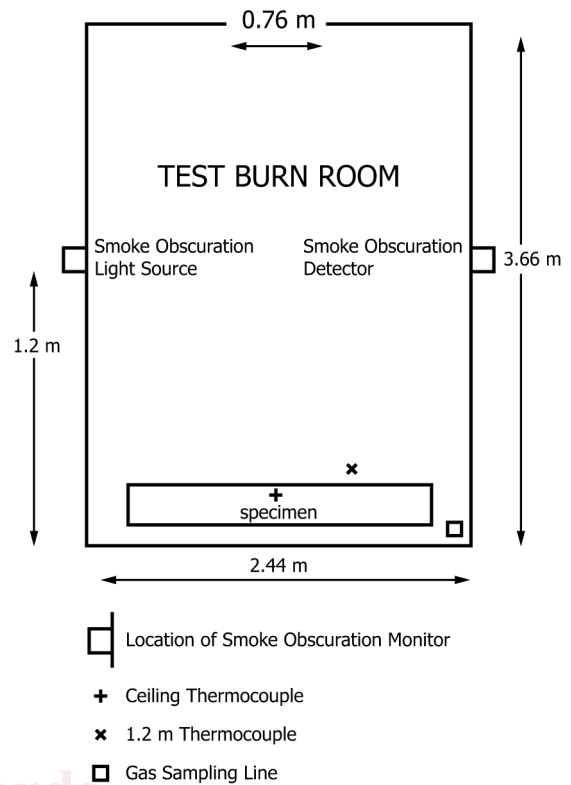

NOTE 1—See text for tolerances; room instrumentation is optional.

FIG. 1 Test Room Configuration A (ASTM room)

the room doorway, such that it collects all the combustion gases. There shall be no obstructions to the air supply to the test setup.

NOTE 2—Both Type X gypsum wallboard and calcium silicate wallboard with a thickness of 12.7 mm (0.5 in.) have been found acceptable. If the wallboard is thicker, it will not affect the results of this test. Gypsum wallboard is likely to generate a measurable amount of heat or smoke release at high heat inputs, due primarily to its paper facer.

5.1.2.1 Install an additional layer of fire rated wallboard on the portions of the walls or ceiling directly adjacent to the test specimen location. Cover at least 1.22 m by 1.22 m (4 ft by 4 ft) of the ceiling with the added wallboard, but do not place an additional layer of wallboard under the test specimen. This ceiling surface is the most severely exposed to flames and heat and needs frequent replacement. Replace any portion of the lining if cracks occur or severe burn damage is observed.

5.1.2.2 Frequently, whenever there is a single test specimen, such as Test Method E1537, Test Method E1590, or Test Method E1822, the test specimen location is the corner of the room furthest away from the doorway. The test specimen also is usually placed on a weighing platform. This test room is unsuitable for Test Method D5424 or Test Method D5537. The test method indicates test specimen location.

5.1.2.3 When testing surface linings (walls or ceilings), weighing of the test specimen during the test is usually not practical. Mass loss during testing, if desired, must be estimated from calculations.

5.1.3 *California Room*—The test room shall have dimensions of 3.05 m ± 25 mm by 3.66 m ± 25 mm by 2.44 m ±

25 mm high (10 ft by 2 ft by 8 ft high). The room shall have no openings other than a doorway opening $0.97\text{ m} \pm 6\text{ mm}$ by $2.06\text{ m} \pm 6\text{ mm}$ (38 in. by 81 in.), located as indicated in Fig. 2, and other small openings, as necessary to make test measurements. Construct the test room of wooden or metal studs, and line it with gypsum wallboard, Type X, or calcium silicate wallboard. Position a hood (see Section 6) outside of the room doorway, such that it collects all the combustion gases. There shall be no obstructions to the air supply to the test set-up.

NOTE 3—Both Type X gypsum wallboard and calcium silicate wallboard with a thickness of 12.7 mm (0.5 in.) have been found acceptable. If the wallboard is thicker, it will not affect the results of this test. Gypsum wallboard likely is to generate a measurable amount of heat or smoke release at high heat inputs, due primarily to its paper facer.

5.1.3.1 Install an additional layer of fire rated wallboard on the portions of the walls or ceiling directly adjacent to the test specimen location. Cover at least 1.22 m by 1.22 m (4 ft by 4 ft) of the ceiling with the added wallboard, but do not place an additional layer of wallboard under the test specimen. This ceiling surface is the most severely exposed to flames and heat and needs frequent replacement. Replace any portion of the lining if cracks occur or severe burn damage is observed.

5.1.3.2 This test room commonly is used for furniture testing only. Usually, the test specimen is located in a corner and placed on a weighing platform. This test room is unsuitable for Test Methods D5424 or D5537. The test method indicates test specimen location.

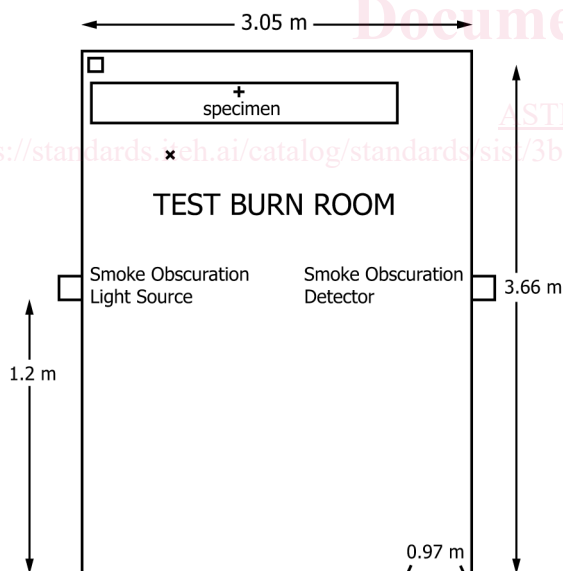

NOTE 1—See text for tolerances; room instrumentation is optional.
FIG. 2 Test Room Configuration B (CA Room)

5.1.3.3 When testing surface linings (walls or ceilings), weighing of the test specimen during the test is usually not practical. Mass loss during testing, if desired, must be estimated from calculations.

5.1.4 Cable Tray Test Room:

5.1.4.1 The test room shall have floor dimensions of $2.44\text{ m} \pm 25\text{ mm}$ by $2.44\text{ m} \pm 25\text{ mm}$, with a height of $3.35\text{ m} \pm 25\text{ mm}$ (8 ft \pm 1 in. by 8 ft \pm 1 in. by 11 ft \pm 1 in. high). On top of the walls there shall be a pyramidal collection hood (see Section 6 for exhaust system information), with a collection box. The walls shall have a maximum conductive heat flux loss of $6.8\text{ W}/(\text{m}^2\text{K})$ (30 Btu/h-ft²), based upon an inside wall temperature of $38\text{ }^\circ\text{C}$ (100 $^\circ\text{F}$) and an outside air temperature of $24\text{ }^\circ\text{C}$ (75 $^\circ\text{F}$), and the interior surface of the walls shall be painted flat black.

5.1.4.2 Any materials of construction that meet the above requirements are acceptable. Two examples of acceptable construction materials are nominally 152 mm (6 in.) thick concrete masonry blocks (density: 1700 kg m^{-3} (106 lb ft⁻³) and thermal conductivity nominally $k = 1.75\text{ W}/(\text{m K})$, at $21\text{ }^\circ\text{C}$; 12.13 Btu in./ft² h $^\circ\text{F}$, at 70 $^\circ\text{F}$) or nominally 13 mm (0.5 in.) gypsum board, with $89\text{ mm} \pm 6\text{ mm}$ (3.5 in. \pm 0.25 in.) of standard fiberglass insulation, with an R value of $1.94\text{ m}^2\text{ K}/\text{W}$ (which corresponds in practical units to an R value of 11 h ft² $^\circ\text{F}/\text{Btu}$). Windows for observation of the fire test are allowed in the walls; ensure that the total area of the windows does not exceed 1.86 m^2 (20 ft²).

5.1.4.3 Select materials of construction which withstand the high temperatures and presence of open flame within the test enclosure and duct. An acceptable construction consists of concrete masonry blocks nominally 203 mm high by 406 mm wide by 152 mm thick (8 in. by 16 in. by 6 in.).

5.1.4.4 Provide air intakes at the base of two opposite walls, one of which contains the access door. Ensure that the total cross sectional area of the air intakes is $1.45\text{ m}^2 \pm 0.03\text{ m}^2$ (2250 in.² \pm 50 in.²), and that the intake areas are divided approximately equal. The air intakes are 559 mm by 343 mm high (22 in. by 13.5 in.) either side of the door, 914 mm by 343 mm high (36 in. by 13.5 in.) under the door, and the entire back wall length, with a height of 305 mm (12 in.). Air intakes are not permitted in either of the other two walls.

5.1.4.5 The door shall be constructed with wired glass, and shall measure $900\text{ mm} \pm 25\text{ mm}$ wide and $2100\text{ mm} \pm 25\text{ mm}$ high (35 in. \pm 1 in. by 83 in. \pm 1 in.), with an overall conductive heat flux loss no greater than that of the walls, that is, $6.8\text{ W}/(\text{m}^2\text{K})$ (30 Btu/h-ft²). A steel-framed wired glass door will meet these requirements. Adequately seal the sides and top of the door to prevent drafts.

5.1.4.6 Construct a truncated pyramid stainless steel hood, formed as shown in Fig. 3, and locate it on top of the enclosure walls. Make the slope on each side of the hood 40°. Form a seal between the hood and the walls; a compressible inorganic batting as gasket is suitable. Insulate the exterior of the hood to make an overall conductive heat loss no greater than that of the walls. Locate a cubical stainless steel collection box, $910\text{ mm} \pm 25\text{ mm}$ (36 in. \pm 1 in.), on a side on top of the exhaust hood, with a nominal $410\text{ mm} \pm 25\text{ mm}$ (16 in. \pm 1 in.) diameter stainless steel pipe exhaust duct centered in one side.

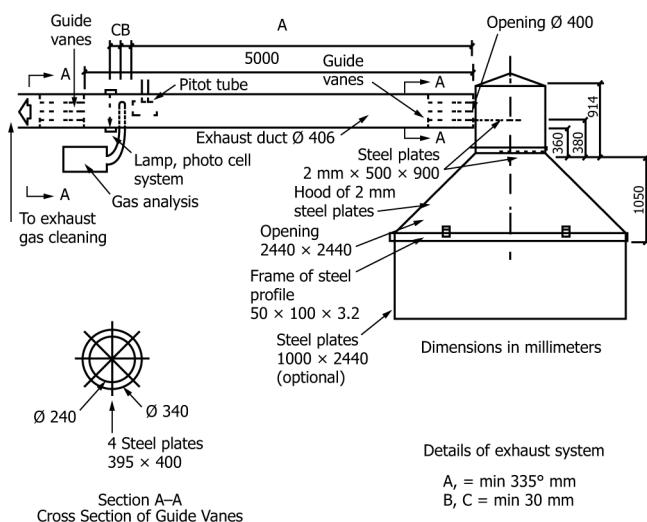

FIG. 3 Design of Hood and Exhaust System

5.2 Nonstandard Rooms:

5.2.1 Standardized tests also are conducted in rooms of somewhat different dimensions than the ASTM or California rooms, after the attainment of equivalent results has been demonstrated.

5.2.2 Nonstandardized tests and research experiments are conducted in rooms of different sizes. The compartment size, shape, and openings shall be chosen to simulate the nature or type of compartment or facility in which the subject material, product, or system is expected to be used in actual service. If there is a range of sizes, then account shall be taken of the fact that for a given ignition exposure, the smaller compartment sizes usually will provide the most severe fire development conditions. Whenever possible, a compartment shall be designed to be symmetrical and as simple as possible for ease of analysis. Space between the top of door and the ceiling is critical because of the trapping of the smoke and hot gases. The room shall be located inside a larger, carefully ventilated enclosure to ensure minimum interference from drafts or wind currents.

5.2.3 Follow the guidelines of 5.1.2 or 5.1.4 for the construction materials, depending on the application. Be especially mindful of the use of additional fire rated wallboard if test specimens are placed near walls or ceilings.

5.3 Furniture Calorimeter (Open Calorimeter):

5.3.1 This type of testing is appropriate for intermediate scale test methods, such as Test Method E1623, and for testing individual products, such as items of furniture, or relatively large constructions, such as foam displays (UL 1975). Position the test specimen centrally on a weighing platform, which shall be located centrally under the collection hood.

5.3.2 The test enclosure that houses the exhaust hood shall be of sufficiently large dimensions that there are no spurious heat radiation effects from the walls or any other nearby objects. The air flow to the test specimen shall be symmetrical from all sides. The hood is located directly above the test specimen (see Section 6).

5.3.3 A standard fire test developed by the NFPA Technical Committee on Fire Tests and published as NFPA 289 uses a gas

burner at various incident heat inputs to expose a variety of individual fuel packages, including single decorative objects, exhibit booths, stage settings and decorative combustible vegetation. The test method is referenced in several codes. The gas burner used is a propane burner with a 305 mm by 305 mm (nominal) top surface and it is the same burner as in NFPA 286 (room-corner test). The gas supply to the burner produces a net heat output of one of the following six ignition source intensities for a period of 15 min: 20 kW, 40 kW, 70 kW, 100 kW, 160 kW, and 300 kW.

5.4 Enclosure Room:

5.4.1 Any test room, as well as any furniture calorimeter, together with the corresponding hood and exhaust duct system, shall be positioned in a large enclosed room. The enclosure area shall be constructed of fire resistant materials, such as concrete, for walls and ceiling, and it shall be completely isolated from neighboring rooms and facilities. The walls of the enclosure shall be far enough away from the walls of the test room for the enclosure room to be ventilated adequately. The height of the ceiling shall be sufficient to allow for installation of the exhaust duct and easy access to the heat release calorimetry and other instrumentation.

5.4.1.1 It is important that during each test a free and sufficient flow of make-up air be available to facilitate the combustion process, without creating any forced flow of air into or out of the test room. The combination of exhaust hood and enclosure room shall be sufficiently large to achieve this objective.

5.4.1.2 Distances of at least 6 m (20 ft) between the enclosure walls and the walls of the test room and a minimum height of 4.6 m (15 ft) are recommended, as minimum requirements; larger enclosure rooms are even more desirable since they will minimize any effects of the enclosure walls on the test conditions. Such effects include radiative feedback from the heated walls and obstruction of air supply into the room. A larger enclosure also will provide easier access to all sides of the test room and instrumentation during the tests, and in case of an emergency, and for routine repairs and maintenance. See 11.2.14 for information regarding smaller enclosure rooms.

5.4.2 The enclosure shall allow for sufficient supply of fresh air into the test room during tests and shall not create any obstructions to the ambient air supply. Openings in the enclosure shall not be situated in a way that would create any forced convective air flows inside the test room, and thus, affecting the burning of the test specimen.

5.4.3 When using an open (furniture) calorimeter, it is recommended that a minimum distance of 6 m (20 ft) be maintained between enclosure walls and the test specimen in all directions.

6. Hood and Exhaust Collection System

6.1 The exhaust collection system shall consist of a blower, steel hood, duct, bidirectional probe, thermocouple(s), oxygen measurement system, smoke obscuration measuring system (white light or laser), and combustion gas sampling and analysis system.

6.1.1 The system for collecting the combustion products shall have a capacity and be designed in such a way that all of the combustion products leaving the burning specimen are collected. Design the capacity of the evacuation system so as to exhaust and collect all combustion gases leaving the burning test specimen without excessive make-up air.

6.2 Place probes for sampling of combustion gas and for measurement of flow rate in accordance with 6.3. Measure all combustion product (smoke obscuration and gas concentrations) at a position in the exhaust duct where the exhaust is uniformly mixed and there is a nearly uniform velocity across the duct section. A distance of 8 to 30 duct diameters is satisfactory for this purpose.

6.3 *Instrumentation in Exhaust Duct*—Further details are set out in Section 7.

6.3.1 *Flow Rate*—Measure the flow rate in the exhaust duct by means of a bidirectional probe located at the center line of the duct. Measure the flow rate in the exhaust duct with an accuracy of at least $\pm 10\%$. The response time to a stepwise change of the duct flow rate shall be a maximum of 6 s to reach 90 % of the final value.

6.3.2 *Combustion Gas Analysis*:

6.3.2.1 *Sampling Line*—Make the sampling line tubes of a material not influencing the concentration of the combustion gas species to be analyzed. See 7.1 for the sequence of the gas train.

6.3.2.2 *Oxygen Measurement*—The analyzer shall measure oxygen concentration with a range from 0 % to 25 % oxygen. The analyzer shall exhibit a linear response and drift of not more than 50 ppm of oxygen over a period of 20 min, and noise of not more than 50 ppm of oxygen (root-mean-square value) during this same 20 min period in order to have adequate measurements of rate of heat release. Recommended procedures for determining drift and noise of the oxygen analyzer are described in Appendix X1. Take the combustion gas sample from the end of the sampling line. Calculate the time delay, including the time constant of the instrument, from the test room, which is a function of the exhaust duct flow rate. It shall be no more than 30 s.

6.3.2.3 *Carbon Monoxide and Carbon Dioxide Measurement*—Measure the combustion gas species with an instrument having an accuracy of at least ± 0.1 volume % for carbon dioxide and ± 0.02 volume % for carbon monoxide. A suitable output range is 0 volume % to 1 volume % for carbon monoxide and 0 volume % to 6 volume % for carbon dioxide. Take the combustion gas sample from the end of the sampling line. Calculate the time delay, including the time constant of the instrument, from the test room; it is a function of the exhaust duct flow rate. It shall be a maximum of 30 s.

6.3.2.4 *Smoke Obscuration Measurement*—Install an optical system for measurement of light obscuration across the centerline of the exhaust duct. Determine the optical density of the smoke by measuring the light transmitted with a photometer system consisting of a lamp, plano convex lenses, an aperture, a photocell, and an appropriate power supply. Construct the system so that soot deposits on the optics during a test do not reduce the light transmission by more than 5 %. Alternatively, instrumentation using a laser beam system, with an 0.5 mW

2.0 mW helium-neon laser, instead of white light system is also acceptable. It has been shown that white light and laser systems will give similar results (2-6).

6.4 *Example Design of a Satisfactory Collection Hood and Exhaust Duct*—The system described has been tested in practice and proven to fulfill the requirements (7-8).

6.4.1 The hood is located just outside the room doorway. Its bottom dimensions are 2.4 m by 2.4 m (8 ft by 8 ft) and the height is 1.0 m (3.3 ft). On all four sides steel sheets are extended 1.0 m (3.3 ft) downwards, making the effective height of the hood 2.0 m (6.6 ft). The distance between the lower edge of the hood and the floor (or the weighing platform when using a furniture calorimeter) shall be 1.8 m to 2.0 m (6.0 ft to 6.4 ft). The hood feeds into a plenum having a 0.9 m by 0.9 m (3 ft by 3 ft) cross-sectional area, and a height of 0.9 m (3 ft). The maximum acceptable height of this plenum area is 1.8 m (6 ft), depending on building constraints. In the plenum chamber two baffle (usually steel) plates approximately 0.5 m by 0.9 m (1.6 ft by 3.0 ft) are located to increase mixing of the combustion gases. The hood shall be designed and manufactured so that no spill-over occurs.

6.4.2 The exhaust duct shall be connected with the plenum chamber. The inner diameter of the exhaust duct shall be in the range 400 mm to 760 mm (16 in. to 30 in.). To facilitate flow measurements, guide vanes, if needed, are located at both ends of the exhaust duct. Alternatively, the rectilinear part of the exhaust duct shall have such a length that a fully-developed flow profile is established at the point of measurement.

6.4.2.1 The exhaust duct shall be connected to an evacuation system. The capacity of the evacuation system shall be designed to exhaust all combustion gases leaving the specimen. This requires an exhaust capacity of at least 2.7 kg s^{-1} (about $8000 \text{ m}^3 \text{ h}^{-1}$ at standard atmospheric conditions) corresponding to a driving under pressure of about 2 kPa at the end of the duct. A variable speed exhaust fan with a DC motor drive is suitable for this use. Alternatively, an adjustable frequency controller also is suitable, in conjunction with a single speed exhaust fan.

6.4.2.2 The controller generates an adjustable voltage/frequency output for complete control of the conventional induction motor that runs the exhaust fan. The system allows for control of the exhaust flow rate from zero to the maximum capacity of the fan by adjusting the speed of the motor. It shall be possible to control the exhaust flow from about 0.5 kg s^{-1} up to maximum flow during the test process.

6.4.3 The system shall be capable of measuring rates of heat release with sufficient accuracy (at least 6 %).

6.4.4 When the objective of the tests is to perform comparisons between products expected to release low amounts of heat or smoke, the system shall still be capable of measuring low rates of heat release (such as 10 kW) with sufficient accuracy (at least 6 %). If concentration gradients are found to exist, mixing vanes are an adequate means of addressing the problem.

NOTE 4—It is likely that a single system will not have the same degree of accuracy of heat release rate measurements over a range of heat release rates as high as 1 MW and as low as 10 kW. Tests designed to assess whether flashover will occur, such as NFPA 265, NFPA 286, or ISO 9705,

require measurements as high as 1 MW, while tests designed to assess the suitability of single products, such as Test Methods E1537 and E1590 or UL 1975, require accurate measurements of at levels of < 100 kW; thus, measurement accuracy must be a function of test requirements.

6.4.5 Use of an alternative exhaust system design is limited to those systems shown to produce equivalent results. Equivalency is demonstrated by meeting the calibration requirements. Exhaust system designs based on natural convection are not permitted.

6.4.6 When using an open calorimeter the hood shall be installed above the mass measuring system and test specimen. The distance between the lower edge of the hood and the mass measuring system shall range between 1.8 m and 3.0 m (6 ft to 10 ft). The hood shall be designed and manufactured such that no spill-over occurs and all the smoke is collected.

NOTE 5—If hoods are too large, potential resulting problems are excessive air entrainment, deposition on cold surfaces, or dilution of smoke.

6.4.7 Leakage of combustion products is detectable visually during burn tests. Visually observe the collection of gases and smoke through the exhaust duct. If any smoke escapes into the surroundings, even at high exhaust flow rates, use a skirt capable of withstanding the high temperatures, about 1 m (3 ft) wide, to hang around the lower edges of the exhaust hood as a curtain. This curtain will assist in guiding more of the combustion products into the exhaust hood. Note that, if such a curtain is used during burn tests, all system calibrations also shall have been conducted with this curtain in place.

6.5 If pollution abatement equipment is present, the exhaust removal system shall still be capable of fulfilling the requirements of the test method throughout the entire test, without affecting the results. If the system affects test results, such results as are obtained after the effect of the abatement equipment come into effect are invalid.

7. Exhaust Duct Instrumentation

7.1 A gas analysis system is required to make measurements of oxygen (for determining heat release), and other gaseous species, such as carbon monoxide, carbon dioxide and any other species of interest, in the exhaust duct. The sequence of the gas train shall be sampling probe, soot filter, cold trap, gas path pump, vent valve, plastic drying column and carbon dioxide removal columns (if used), flow controller, and oxygen analyzer. The gas train also shall include appropriate spanning and zeroing facilities. Other designs are acceptable if equivalency has been demonstrated.

7.2 To install the instruments in the duct, and for maintenance purposes, one or more access doors shall be provided in the exhaust duct. These exhaust duct doors shall be sealed tightly during testing.⁸

7.3 Gas Sampling Probe:

7.3.1 The gas sampling probe shall be located in a position where the exhaust duct flow is well mixed (turbulent flow). Install the gas sampling probe at a distance of at least eight duct diameters downstream of the last turn from the exhaust hood.

If the minimum straight section before the measuring system is at least eight times the inside diameter of the duct the exhaust flow is likely to be uniformly mixed. If the measuring system is positioned at a distance of less than eight diameters, equivalent results and good mixing shall be demonstrated before use.

7.3.1.1 The following experiment helps to determine how well the exhaust gases are being mixed. Position a gas burner, such as the burners described in 11.2.3 or 11.2.4, at the location of the test specimen in the test room (or under the exhaust hood if using an open calorimeter). Burn propane gas at a constant gas flow, for example 54 L/min, which produces an 80 kW fire. Allow the gas to burn for 2 min to 3 min to reach a steady state. Use a plain L-shaped 6 mm (0.25 in.) stainless steel tube facing downstream of the exhaust duct at the sampling location of the actual gas sampling probe. Traverse the tube from top to bottom of the duct in 25 mm (1 in.) increments. Record the combustion gas concentration at each position and inspect the recorded values. If gas concentrations are fairly constant (within 10 %) throughout the experiment, mixing has been achieved. If gas concentrations vary widely throughout the cross sectional area of the exhaust duct, mixing vanes or baffles need to be added to the exhaust system. Repeat these measurements until good mixing has been achieved.

7.3.2 Sampling probes shall collect samples across the full diameter of the exhaust duct, and thus, preferably be of the bar type and minimize disturbance of the air flow in the duct. Ring type sampling probes also are acceptable, although they do not collect gas samples across the full diameter of the duct. In either case turn the intake of the sampling probe downstream to prevent soot from clogging the probe. The sampling probe shall be manufactured from corrosion resistant materials, such as stainless steel or polytetrafluoroethylene. Collect the combustion gas samples across the entire diameter of the exhaust duct. Install the gas sampling probe at the center of the cross-sectional area of the exhaust duct with the holes facing downstream of the flow.

7.3.2.1 Inspect the sampling probe frequently and remove any particulate deposit in the holes or in the line. The frequency of required cleaning of the probe depends on the frequency and intensity of the tests conducted in any facility. When all components of the gas train, such as all filters, cold bath, valves, rotameters and pump are clean, but a sufficient flow cannot be maintained through the analyzers, this is an indication that the sampling probe holes are probably clogged. In this case, the sampling probe shall be removed and cleaned. Methanol or other solvents are often needed to remove hard soot deposits and other contaminants. Reinstall the gas sampling probe after cleaning and make sure all the openings are sealed and there is no leakage into the system. The sampling probe shall be cleaned with a frequency no less than monthly.

7.3.2.2 It is possible to install the gas sampling probe facing upstream of the flow; however, in this condition the probe holes will clog more quickly and need to be cleaned more often.

7.3.3 *Gas Sampling Line*—The gas sampling line shall be positioned at the desired location, made from a material not influencing the concentration of the combustion gas species to

⁸ High-temperature silicone rubber sealant is suitable for this purpose.

be analyzed. Transport combustion gases through a heated (preferably electrically) line to prevent condensation of moisture or other combustion products in the line. Maintain the heated line at a temperature of at least 110 °C (230 °F). Remove particulates contained in combustion gases with inert filters. Use oil-free pumps, such as diaphragm pumps, to transport sample gases from the test room to the gas analyzers. All tube fittings and pipe connections throughout the length of the gas train shall be gas tight so as to ensure that no gas leakages occur in the system. This is particularly crucial on the suction side of the gas sampling pump where outside air might be drawn into the system and dilute the stream of sample gas. Leakage of air into the sample gas will cause serious errors in the gas concentration measurements.

NOTE 6—All tube fittings and pipe connections in the gas analysis system shall be made of stainless steel or other corrosion resistant materials to avoid corrosion. Corrosion of gas handling tubes and fittings potentially affects the chemical composition of the sample gas and causes serious errors in the test measurements.

NOTE 7—Heated lines are not necessary for the measurement of carbon monoxide, carbon dioxide, or oxygen; however, utilization of heated lines is necessary for the following gases: water, hydrogen chloride, and condensable hydrocarbons. Moreover, even if these gases are not being measured, the use of heated lines prevents their deposition inside the sampling tube, which potentially will reduce or obstruct the free flow of gases inside the line.

7.3.4 *Particulate Filter and Removal System for Condensables:*

7.3.4.1 The gas sample entering the gas analyzers shall be free of moisture, soot, condensable hydrocarbons, and any other particulates. Use in-line filters to remove soot and other particulates before the gas sample enters the gas analysis system. These filters shall be replaced daily; however, in some cases line filters need to be replaced after each fire test, especially if the burn has been particularly intense or especially sooty. Soot filters shall be replaced when needed, to ensure a free and sufficient flow of sample gas through the gas analyzers during the test.

7.3.4.2 Use a removal system to remove the water content of the gas sample, and condensables, continuously, as discussed in 7.3.4.3 – 7.3.4.5.

7.3.4.3 One option for water removal system is a cold trap. A cold trap (refrigeration system) consists of condensing unit, compressor and evaporator unit, and often also contains a temperature control unit.

7.3.4.4 The concept of the cold trap is to continuously cool the sample gas in order to condense the water content in the mixture of gases and provide a moisture-free stream of sample gases to the gas analyzers. An ice bath often is used as a valid alternative.

7.3.4.5 A different valid alternative to a chiller of any kind is the use of a selective permeability membrane drier, which has been shown to be very effective (7).

7.3.4.6 Neither the soot filters nor the condensable removal system shall introduce a large “dead” volume into the gas train. A large “dead” volume is a potential contributor to the loss of peak gas concentration values, especially in the case of sharp peaks.

NOTE 8—Time constants of gas analyzers affect “dead” volumes. Even

though various digital techniques have been proposed to correct system response errors due to “dead” volume, avoidance is recommended.

7.4 *Gas Analyzers:*

7.4.1 The measurement of oxygen concentration is at the heart of the determination of rate of heat release by the principle of oxygen consumption. For improved accuracy in rate of heat release measurements, particularly for large fires, measurements of carbon monoxide and carbon dioxide concentrations are helpful.

7.4.2 *Specifications for Oxygen Measurement*—The analyzer shall measure oxygen concentration with a range from 0 % to 25 % oxygen. The analyzer shall exhibit a linear response and drift of not more than 50 ppm of oxygen over a period of 20 min, and noise of not more than 50 ppm of oxygen (root-mean-square value) during this same 20 min period in order to have adequate measurements of rate of heat release. Recommended procedures for determining drift and noise of the oxygen analyzer are described in **Appendix X1**. Take the combustion gas sample from the end of the sampling line. Calculate the time delay, including the time constant of the instrument, from the test room; it is a function of the exhaust duct flow rate. The time delay is the time to transport sample gases from the source to the inlet port of the gas analyzer, and it shall be as short as possible, up to a maximum of 30 s. The response time of the gas analyzer shall not be greater than 5 s and preferably be in the order of 1 s or less. The lag time is simply subtracted from the recorded time to obtain the actual time of the event at the inlet of the gas analyzer.

NOTE 9—The most satisfactory oxygen analyzers are those of the paramagnetic type (see **Appendix X1**).

7.4.3 *Specifications for Carbon Dioxide and Carbon Monoxide Measurement*—Measure the combustion gas species with an instrument having an accuracy of at least ± 0.1 volume % for carbon dioxide and ± 0.02 volume % for carbon monoxide. A suitable output range is 0 volume % to 1 volume % for carbon monoxide and 0 volume % to 6 volume % for carbon dioxide. Take the combustion gas sample from the end of the sampling line. Calculate the time delay, including the time constant of the instrument, from the test room; it is a function of the exhaust duct flow rate. It shall be a maximum of 30 s. The response of the gas analyzers shall not be greater than 5 s and preferably be in the order of 1 s or less.

NOTE 10—Carbon monoxide and carbon dioxide non dispersive infrared analyzers have been shown to be satisfactory. Instruments exist, which assess both carbon monoxide and carbon dioxide.

NOTE 11—The upper limit of the analyzers is exceeded occasionally in flashover situations. This error, however, often is of relatively low consequence, because, frequently, it is measured in tests after flashover.

7.4.4 *Considerations for Response Times in Calculation of Rate of Heat Release*—The calculated rate of heat release depends on measured values of several time dependent parameters: temperature, differential pressure, and concentrations of oxygen, carbon monoxide, and carbon dioxide (if the latter two are measured). It is of utmost importance that all values of these parameters used in the heat release equations correspond to the same event and time. If the values of these parameters do not correspond to the same instant in real time, the rate of heat

release calculations will be inaccurate. The response of thermocouples and pressure transducers to variations in temperature or pressure in the exhaust duct is usually rapid and normally corresponds to a negligible time delay; however, the time response of gas analyzers is not rapid, and time delays shall be measured. There are two principal types of delay involved in gas measurements: the time for gas to be transported from the source to the inlet port of the gas analyzer (the lag time), and the time it takes the gas analyzer to respond to the incoming sample and actually measure gas concentration (the “response time,” or “time constant,” of the gas analyzer). The response time of any instrument is a characteristic of its system and depends on the type of the instrument and its principle of operation. The “delay time” is the sum of lag time and instrument response time.

7.4.5 Determination of the Lag Time—The lag time is the time period between the moment when the gas is introduced at the source and the moment when the gas analyzer begins to respond to the gas concentration. The lag time is measured by introducing a volume of a known gas, such as carbon dioxide, at the source, at time zero, and plotting the gas analyzer output against time.

7.4.5.1 For any flow rate in the exhaust duct, one method of assessing lag time is by bursting a large balloon filled with a known gas, such as carbon monoxide, carbon dioxide or methane (if total hydrocarbons are being measured), and recording the gas analyzer’s response. The lag time then is simply subtracted from the recorded time to get a corrected time.

7.4.6 Response Time—Correction for response time is mathematically more complicated and usually requires computer programming; however, for most practical purposes in full-scale fire testing, response times simply are considered as additional delay time and added to the lag time. If the instrument response time is small, less than 1 s, the error due to its effect will not be significant.

7.4.6.1 If the response times of each gas analyzer differ, it is crucial to make response time corrections for each unit individually; therefore, a single constant delay time correction cannot be used for all gas analyzers, unless actual response times are similar.

7.5 Flow Rate—In order to measure the volumetric flow in the exhaust duct, install a bidirectional probe at the centerline of the duct parallel to the flow direction. Measure the volume flow rate in the exhaust duct with an accuracy of at least ±6 %. The response time to a stepwise change of the duct flow rate shall be a maximum of 5 s to reach 90 % of the final value.

7.5.1 Install the bidirectional probe at a position where the flow is fully developed and combustion products gases are well mixed. This will be at least eight duct diameters downstream of the last turn. Install the bidirectional probe at least 0.30 m (1 ft) upstream of the gas sampling probe. The bidirectional probe detects any pressure differential, the difference between the total pressure and the static pressure, in the exhaust duct. The probe consists of a stainless steel cylinder, with a solid diaphragm in its center, dividing it into two chambers. The pressure taps on either side of the diaphragm support the probe.

Position the axis of the probe along the centerline of the duct.⁹ Alternative probes are acceptable, if equivalency of results has been demonstrated.

7.5.2 An electronic pressure transducer with an analog output is required to be used in conjunction with the bidirectional probe. From this and the temperature measurement in the duct, calculate the volume flow rate of the smoke in the exhaust duct using Eq 1 (see also Annex A2 for further details). Connect the two pressure taps of the bi-directional probe to the differential pressure sensor by means of flexible tubing.¹⁰ Ensure that there are no leakages from or to the system. The connecting tubes shall be well insulated and protected from temperature changes or physical damage. The length of the tube between the bidirectional probe and pressure sensor shall be kept at a minimum, typically not much more than the actual distance between the two instruments (leave as little slack as possible). Connecting tubes shall not be folded, bent or broken.

$$\dot{V}_s = \frac{C \cdot \sqrt{[\Delta p \cdot T_e]}}{\rho_0 \cdot 273.15} \quad (1)$$

where:

\dot{V}_s = the volumetric flow rate, under standard conditions (25 °C and 1 atm pressure), in m³/s;

T_e = the gas temperature in the exhaust duct near the bidirectional probe, in K;

p = the pressure differential across the bidirectional probe, in Pa;

ρ_0 = the density of air at 273.15 K temperature; and,

C = a practical calibration factor.

7.5.3 The bidirectional probe in the exhaust duct shall be inspected and cleaned frequently to ensure that all holes and tubings are open fully and the probe is positioned correctly. The frequency of cleaning of the probe depends on the frequency and intensity of tests conducted in any facility. Remove connecting tubes from pressure tabs and blow air through both tabs to remove the soot. For less frequent cleaning, such as monthly clean-up, the bidirectional probe shall be removed and cleaned. Methanol or other solvents often are needed to remove hard deposits of soot and other contaminants. Reinstall the probe carefully at the center of the exhaust duct parallel to the direction of air flow, and make sure all the openings are sealed, and there are no leakages into the system.

7.5.4 Measurement of Flow Rate Profile in the Exhaust Duct—In order to determine whether the flow in the exhaust duct is developed fully, the flow rate profile in the duct shall be measured. The velocity profile also is needed to determine C in Eq 1, the ratio of average to maximum flow rates in the exhaust duct. Figs. 4 and 5 show ways of measuring the flow rate profile. Fig. 5 shows one type of flow rate profile obtainable. In order to obtain the velocity profile, turn on the exhaust fan and run air through the exhaust duct at the desired flow rate, such as 0.47 m³/s (1000 ft³/min). Position the bidirectional probe at 25 mm (1 in.) intervals from one side of the duct to the other.

⁹ A pressure differential sensor in the range of 0.0 torr to 1.0 torr (0.000 in. to 0.5353 in. water), with an electronic signal conditioning display unit providing 0 to 10 VDC output has been found satisfactory.

¹⁰ Suitable types of tubing include “tygon” and polytetrafluoroethylene tubing.

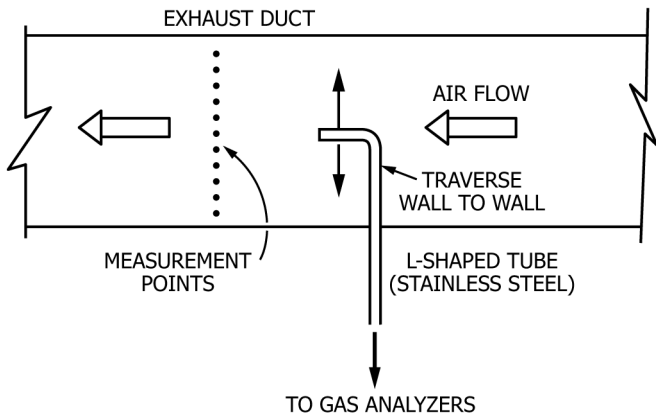

FIG. 4 Testing the Mixing of Gases in the Exhaust Duct

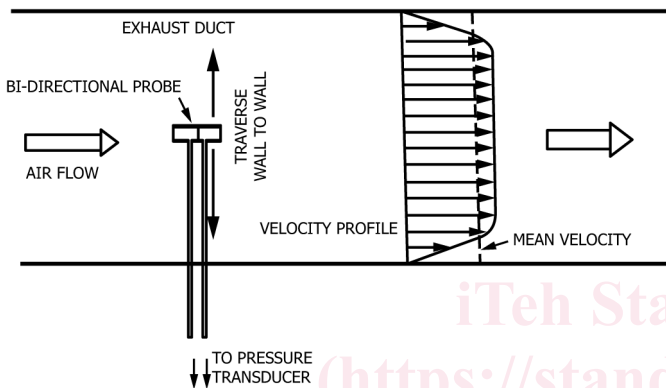

FIG. 5 Bidirectional Probe and Velocity Profile in the Exhaust Duct

Measure the flow rate at each position and obtain an overall profile. Then, determine the flow rate in the duct, and divide the average flow rate by the centerline flow rate to obtain k . Repeat this procedure at different exhaust flow rates.

7.6 Temperature Measurement—Use Chromel-Alumel type K thermocouples, shielded against high heat with insulation capable of resisting temperatures at least to 1200 °C (2200 °F). The thermocouple wire gage shall be 0.51 mm diameter (24 AWG). The total length of thermocouples from the point of measurement to the data acquisition system shall be kept at a minimum. Ensure that the entire length of thermocouple wires is protected against heat and physical damage. To prevent the possibility of breakage thermocouple wires shall not be bent at sharp angles. Make sure thermocouple leads have no contacts or connections other than the junction point. Install connectors in such a way that the bare wires do not contact each other. Thermocouple circuits shall involve at least two junctions: one junction is the measurement point (hot junction), where the two leads are welded together to make a small bead, and the other junction shall be at a known temperature, commonly called reference temperature (cold junction). A common reference temperature is an ice bath kept at 0 °C (32 °F). The cold junction is required to make temperature measurements using thermocouples. The common arrangements are described in many thermocouple manufacturer’s manuals and text books. Many data acquisition systems include software or hardware

thermocouple compensation circuits, which eliminate the need for using a cold reference junction, such as ice bath. Depending on the type of data acquisition system, the temperature is either calculated automatically by the software and stored by the system, or programming is required to calculate the temperature from the measured voltage. Laboratories shall refer to their data acquisition operating manuals for proper application.

NOTE 12—Although higher gage (thinner) thermocouple wire results in slightly more accurate temperature measurements and increased sensitivity, full-scale fire testing typically involves rugged conditions, which makes the use of very fine thermocouples difficult and impractical in such environments. Consequently, it is important to use the specified type and gauge of thermocouples to ensure consistency of test results.

7.6.1 A thermocouple, used to measure the temperature of the incoming gases, shall not be installed downstream in the wake of the bidirectional probe. It shall be installed upstream of the probe, where the exhaust flow is well mixed, such that the fully developed flow of air reaching the probe will not be disturbed. The thermocouple shall be installed at a distance of at least one duct diameter from the bidirectional probe. Alternative thermocouple placements are acceptable provided equivalency of test results has been demonstrated.

7.6.2 For a more representative measurement of exhaust flow temperature a thermopile is installed across the cross-sectional area of the exhaust duct, and the average temperature used in Eq 1. Several thermocouples are connected in series or parallel to make a thermopile. This arrangement increases the sensitivity of temperature measurements. If the hot junctions are at different temperatures and thermocouples all have the same resistance, the temperature measured is the average temperature if the thermocouples are linear over the temperature range being measured. Since the thermopile shall be positioned at a location where duct flow is well mixed, this condition will be satisfied. Fig. 6 shows multiple-junction

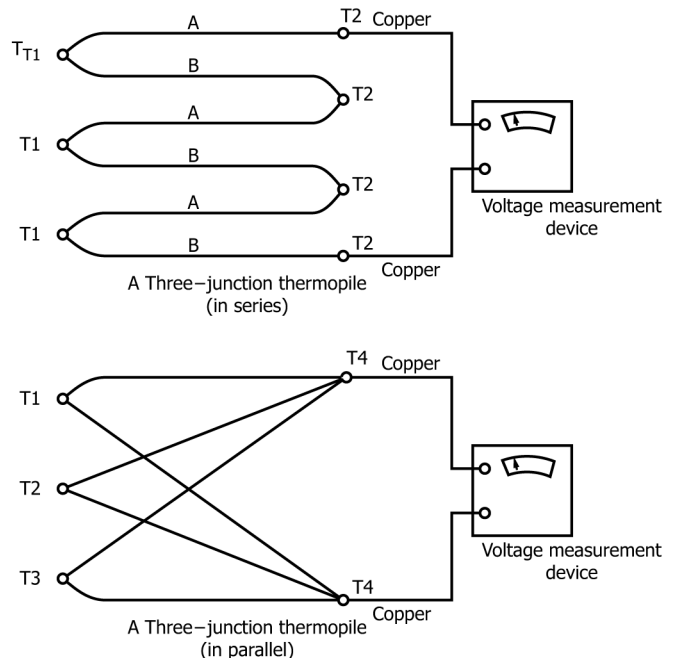

FIG. 6 Multiple-Junction Thermopiles