



Designation: D2983 – 23

Standard Test Method for Low-Temperature Viscosity of Automatic Transmission Fluids, Hydraulic Fluids, and Lubricants using a Rotational Viscometer¹

This standard is issued under the fixed designation D2983; the number immediately following the designation indicates the year of original adoption or, in the case of revision, the year of last revision. A number in parentheses indicates the year of last reapproval. A superscript epsilon (ϵ) indicates an editorial change since the last revision or reapproval.

This standard has been approved for use by agencies of the U.S. Department of Defense.

1. Scope*

1.1 This test method covers the use of rotational viscometers with an appropriate torque range and specific spindle for the determination of the low-shear-rate viscosity of automatic transmission fluids, gear oils, hydraulic fluids, and some lubricants. This test method covers the viscosity range of 300 mPa·s to 900 000 mPa·s

1.2 This test method was previously titled “Low-Temperature Viscosity of Lubricants Measured by Brookfield Viscometer.” In the lubricant industry, D2983 test results have often been referred to as “Brookfield² Viscosity” which implies a viscosity determined by this method.

1.3 This test method contains four procedures: Procedure A is used when only an air bath is used to cool samples in preparation for viscosity measurement. Procedure B is used when a mechanically refrigerated programmable liquid bath is used to cool samples in preparation for viscosity measurement. Procedure C is used when a mechanically refrigerated constant temperature liquid bath is used to cool samples by means of a simulated air cell (SimAir)³ Cell in preparation for viscosity measurement. Procedure D automates the determination of low temperature, low-shear-rate viscosity by utilizing a thermoelectrically heated and cooled temperature-controlled sample chamber along with a programmable rotational viscometer.

1.4 There are multiple precision studies for this test method.

¹ This test method is under the jurisdiction of ASTM Committee D02 on Petroleum Products, Liquid Fuels, and Lubricants and is the direct responsibility of Subcommittee D02.07 on Flow Properties.

Current edition approved Nov. 1, 2023. Published November 2023. Originally approved in 1971. Last previous edition approved in 2022 as D2983 – 22. DOI: 10.1520/D2983-23.

² Brookfield viscometer and accessories are a trademark of AMETEK Brookfield, Inc, 11 Commerce Blvd., Middleboro, MA 02346, <http://www.brookfieldengineering.com>.

³ SimAir is a trademark of Tannas Co., 4800 James Savage Rd., Midland, MI 48642, <http://www.savantgroup.com>.

1.4.1 The viscosity data used for the precision studies for Procedures A, B, and C covered a range from 300 mPa·s to 170 000 mPa·s at test temperatures of -12°C , -26°C , and -40°C . Appendix X5 includes precision data for -55°C test temperature and includes samples with viscosities greater 500 000 mPa·s.

1.4.2 The viscosity data used for Procedure D precision study was from 6400 mPa·s to 256 000 mPa·s at test temperatures of -26°C and -40°C .

1.5 The values stated in SI units are to be regarded as standard. No other units of measurement are included in this standard.

1.5.1 The test method uses the SI unit, milliPascal-second (mPa·s), as the unit of viscosity. (1 cP = 1 mPa·s).

1.6 **WARNING**—Mercury has been designated by many regulatory agencies as a hazardous substance that can cause serious medical issues. Mercury, or its vapor, has been demonstrated to be hazardous to health and corrosive to materials. Use Caution when handling mercury and mercury-containing products. See the applicable product Safety Data Sheet (SDS) for additional information. The potential exists that selling mercury or mercury-containing products, or both, is prohibited by local or national law. Users must determine legality of sales in their location.

1.7 *This standard does not purport to address all of the safety concerns, if any, associated with its use. It is the responsibility of the user of this standard to establish appropriate safety, health, and environmental practices and determine the applicability of regulatory limitations prior to use.*

1.8 *This international standard was developed in accordance with internationally recognized principles on standardization established in the Decision on Principles for the Development of International Standards, Guides and Recommendations issued by the World Trade Organization Technical Barriers to Trade (TBT) Committee.*

*A Summary of Changes section appears at the end of this standard

2. Referenced Documents

2.1 ASTM Standards:⁴

- D341** Practice for Viscosity-Temperature Equations and Charts for Liquid Petroleum or Hydrocarbon Products
 - D2162** Practice for Basic Calibration of Master Viscometers and Viscosity Oil Standards
 - D4175** Terminology Relating to Petroleum Products, Liquid Fuels, and Lubricants
 - D5133** Test Method for Low Temperature, Low Shear Rate, Viscosity/Temperature Dependence of Lubricating Oils Using a Temperature-Scanning Technique
 - D5293** Test Method for Apparent Viscosity of Engine Oils and Base Stocks Between $-10\text{ }^{\circ}\text{C}$ and $-35\text{ }^{\circ}\text{C}$ Using Cold-Cranking Simulator
 - D6708** Practice for Statistical Assessment and Improvement of Expected Agreement Between Two Test Methods that Purport to Measure the Same Property of a Material
 - D6821** Test Method for Low Temperature Viscosity of Drive Line Lubricants in a Constant Shear Stress Viscometer
 - D7962** Practice for Determination of Minimum Immersion Depth and Assessment of Temperature Sensor Measurement Drift
 - D8210** Test Method for Automatic Determination of Low-Temperature Viscosity of Automatic Transmission Fluids, Hydraulic Fluids, and Lubricants Using a Rotational Viscometer
 - D8278** Specification for Digital Contact Thermometers for Test Methods Measuring Flow Properties of Fuels and Lubricants
 - E1** Specification for ASTM Liquid-in-Glass Thermometers
- ### 2.2 ISO Standard:⁵
- ISO 17025** General requirements for the competence of testing and calibration laboratories

3. Terminology

3.1 Definitions:

3.1.1 *apparent viscosity, n*—the determined viscosity obtained by use of this test method. **D4175**

3.1.1.1 *Discussion*—Apparent viscosity may vary with the spindle speed (shear rate) of a rotational viscometer if the fluid is non-Newtonian. See **Appendix X1** for a brief explanation.

3.1.2 *digital contact thermometer (DCT), n*—an electronic device consisting of a digital display and associated temperature sensing probe.

3.1.2.1 *Discussion*—This device consists of a temperature sensor connected to a measuring instrument; this instrument measures the temperature-dependent quantity of the sensor, computes the temperature from the measured quantity, and provides a digital output. This digital output goes to a digital display and/or recording device that may be internal or external to the device.

⁴ For referenced ASTM standards, visit the ASTM website, www.astm.org, or contact ASTM Customer Service at service@astm.org. For *Annual Book of ASTM Standards* volume information, refer to the standard's Document Summary page on the ASTM website.

⁵ Available from American National Standards Institute (ANSI), 25 W. 43rd St., 4th Floor, New York, NY 10036, <http://www.ansi.org>.

3.1.2.2 *Discussion*—The devices are often referred to as a “digital thermometers,” however the term includes devices that sense temperature by means other than being in physical contact with the media.

3.1.2.3 *Discussion*—PET is an acronym for portable electronic thermometers, a subset of digital contact thermometers (DCT).

3.2 Definitions of Terms Specific to This Standard:

3.2.1 *blank sample, n*—a Newtonian standard reference fluid used to monitor the temperature experienced by the sample in the cold-air cabinet by inserting a thermometric device while placed in the center of the turntable; this fluid shall have a viscosity as low as possible and be changed on a regular basis.

3.2.2 *final test temperature, n*—for the programmable liquid bath is the test temperature at which the liquid bath will be held for the rest of the 16 h after the cooling profile is completed.

3.2.3 *intermediate setpoints, n*—for the programmable liquid bath are the series of setpoints the bath is taken through while the cooling profile is executing. This cooling profile calculated from **A2.2** is automatically executed by the software.

3.2.4 *reference viscosity, n*—the viscosity of Newtonian reference fluid whose values were determined by the use of a master viscometer at one or more temperatures; reference viscosities of typical standard reference fluids used in Procedures A, B, and C are listed in **Appendix X2**.

3.2.5 *initial viscosity, n*—the viscosity measured during the first 5 s to 10 s of spindle rotation.

3.2.5.1 *Discussion*—For Procedure D, which is conducted at multiple speeds, this is 7 s to 9 s of spindle rotation at the indicated speed.

3.2.6 *stabilized viscosity, n*—the viscosity measured after 60 s to 180 s of spindle rotation.

3.2.6.1 *Discussion*—For Procedure D, which is conducted at multiple speeds, this is 160 s to 179 s of spindle rotation at the indicated speed.

3.2.7 *Procedure A*—This test protocol utilizes an air bath for the cooling portion of the test and then requires moving the test cells to either a constant liquid bath or balsa blocks during the viscosity analysis.

3.2.8 *Procedure B*—This test protocol utilizes a programmable liquid bath to cool the samples at a pre-determined rate and then the viscosity analysis is performed in the same bath.

3.2.8.1 *starting temperature, n*—for the programmable liquid bath, used in Procedure B, is the temperature of the liquid bath at which the samples are loaded into the turn table. This is calculated from **A2.2** at zero time. The software provided with the programmable liquid bath automatically calculates this value.

3.2.9 *Procedure C*—This test protocol utilizes a constant liquid bath and Sim-Air cells, which allow the samples to cool at the same rate as the air bath, and be tested within the same constant liquid bath.

3.2.10 *Procedure D*—This test protocol uses a programmable rotational viscometer paired with a thermoelectrically

controlled sample chamber. The viscometer program automatically records the sample temperature during the thermal conditioning through the end of test. At the end of thermal conditioning, the viscosity is automatically measured at each test method spindle speed with a summary reported at the end of test.

3.2.10.1 *viscometer tray, n*—the support platform on which the viscometer is mounted; used in Procedure D.

3.2.10.2 *viscometer retaining ring, n*—the collar that holds the viscometer in position on the viscometer tray; used in Procedure D.

3.2.10.3 *test chamber retaining ring, n*—cone shaped collar that secures the sample tube in the test chamber; used in Procedure D.

4. Summary of Test Method

4.1 *For Procedures A, B, and C*—An oleaginous fluid sample is preheated, allowed to stabilize at room temperature, and then poured to a predetermined depth into a glass cell, and an insulated or uninsulated spindle is inserted through a special stopper and suspended by a clip. An alternative sample preparation is to fill a glass cell or stator to the predetermined depth with the oleaginous fluid, an insulated or uninsulated spindle is inserted through a special stopper and suspended by a clip; then this entire sample assembly is preheated and allowed to come to room temperature. A reference fluid with a known viscosity value is also prepared. The contained sample is cooled to a predetermined temperature for 16 h and analyzed by a rotational viscometer and, depending on the viscometer model used, the viscosity of the test fluid is read directly from the viscometer or the resultant torque reading is used to calculate the initial and stabilized viscosity of the oil at the temperature chosen. The reference fluid is used to verify the test temperature for accuracy purposes.

4.2 *For Procedure D*—A 20 mL sample of the test fluid is heated to 50 °C and held there for 30 min before cooling to room temperature. This is followed by cooling in a prescribed manner that mimics a sample cooling in an air bath to the test temperature which follows Newton's Cooling Law. This thermal conditioning is consistent with that described in [Annex A2](#) with the constants noted in [Annex A5](#). The sample is cooled to test temperature in 1.7 h, then held there for 14 h before the viscosity is measured with a specific insulated spindle at specific series of shear rates (rotational speeds). When the viscosity measurements are complete the sample chamber is returned to room temperature. This procedure is the same as option A of Test Method [D8210](#).

4.2.1 From the beginning of a test until viscosity measurements are complete, the digital viscometer records elapsed time and sample temperature. Near the end of the thermal conditioning the viscosity is measured at spindle speeds of 0.6 rpm, 1.5 rpm, 3.0 rpm, 6.0 rpm, 12 rpm, 30 rpm, 60 rpm, and 120 rpm for 180 s at each speed. Two average viscosities are calculated for each spindle speed. An initial viscosity is the average from 7 s to 9 s at a spindle speed. The stabilized viscosity is the average from 160 s to 179 s at a spindle speed. The results are shown in table format in order of increasing

spindle speeds listing the spindle speed, viscosity, torque, and temperature. The test data can be printed or saved to a CSV-formatted ASCII file, which provides a record to both the thermal conditioning and viscosity measurements. Confirmation of the thermal conditioning can be verified by plotting elapsed time versus temperature recorded in the data file.

5. Significance and Use

5.1 The low-temperature, low-shear-rate viscosity of automatic transmission fluids, gear oils, torque and tractor fluids, and industrial and automotive hydraulic oils (see [Appendix X4](#)) are of considerable importance to the proper operation of many mechanical devices. Measurement of the viscometric properties of these oils and fluids at low temperatures is often used to specify their acceptance for service. This test method is used in a number of specifications.

5.2 Initially this test method was developed to determine whether an automatic transmission fluid (ATF) would meet OEM low temperature performance criterion originally defined using a particular model viscometer.^{6,7} The viscosity range covered in the original ATF performance correlation studies was from less than 1000 mPa·s to more than 60 000 mPa·s. The success of the ATF correlation and the development of this test method has over time been applied to other fluids and lubricants such as gear oils, hydraulic fluids, and so forth.

5.3 Procedures A, B, C, and D of this test method describe how to measure apparent viscosity directly without the errors associated with earlier techniques that extrapolated experimental viscometric data obtained at higher temperatures.

NOTE 1—Low temperature viscosity values obtained by either interpolation or extrapolation of oils may be subject to errors caused by gelation and other forms of non-Newtonian response to spindle speed and torque.

5.4 Procedures A, B, C, and D; If viscosity measurements are difficult to stabilize or a noticeable decrease in viscosity is seen at a constant speed between an initial measurement made during the 5 s to 10 s after the spindle rotation commences and the stabilized measurement between 60 s and 180 s, then this most likely indicates time-dependent, structural breakdown in the fluid. Some formulated fluid types may form wax structures when soaked at or below a certain low temperature which varies among fluids. The rotating spindle of the viscometer can degrade this structure over time, resulting in a decrease in the apparent viscosity at longer measurement times. This can obscure a higher initial viscosity. It is possible that this high initial viscosity may be detrimental to certain machinery, as historically seen in some automatic transmissions. It was the reason for developing this test.^{6,7} It is recommended, that if this phenomenon is observed, the suitability of this fluid for the application is carefully considered. If desired, Test Method

⁶ Selby, T., "Automatic Transmission Fluid Viscosity at Low-Temperature and its effect on transmission performance," SAE Technical Paper 600049, 1960, <https://doi.org/10.4271/600049>.

⁷ Low-Temperature Fluidity Panel of the Power-Transmission and Power-Steering Units and Fluids Group, "Development of Research Technique for Evaluating the Low-Temperature Fluidity of Automatic Transmission Fluids," *CRC Report #367*, Coordinated Research Council, May 1963, Online, Available: <https://crao.org/wp-content/uploads/2022/01/CRC-367.pdf>, 14 January 2022.

D5133 or Test Method D6821 may be used to study the behavior of these fluids.

6. Apparatus

6.1 Rotational Viscometer:

6.1.1 Procedures A, B, and C—A rotational viscometer with a maximum torque between 0.0670 mN·m and 0.0680 mN·m and capable of sensing a change in torque of less than 0.00067 mN·m. It shall output torque data at a rate of at least one point per second and have a selection of spindle speeds consisting of at least 0.6 r/min, 1.5 r/min, 3.0 r/min, 6.0 r/min, 12.0 r/min, 30.0 r/min, and 60.0 r/min. Additional spindle speeds of 0.3 r/min and 120 r/min are desirable. The viscometer is to be calibrated at least yearly.

6.1.2 Procedure D—A programmable digital rotational viscometer with selectable spindle speeds and a maximum torque between 0.0670 mN·m and 0.1800 mN·m and capable of sensing a change in torque of less than 0.3 % of maximum torque. The viscometer shall have an accuracy that is no more than ±1 % of maximum torque. The selection of spindle speeds is at least 0.6 r/min, 1.5 r/min, 3.0 r/min, 6.0 r/min, 12.0 r/min, 30.0 r/min, 60.0 r/min, and 120 r/min. It shall have an integrated resistive temperature device (RTD) sensor with a calibrated range from -45 °C to +90 °C with a resolution of 0.1 °C or less. It shall be capable of automatically initiating the viscosity measurement after a specified elapsed test time, at multiple spindle speeds with each for a specific duration. It shall record elapsed time, temperature, spindle speed, torque, and viscosity throughout a test consistent with data collection parameters in Annex A6. A summary of the measured viscosity, torque, and spindle speed will be displayed at test completion with an option to print or save.

6.2 Viscometer Spindle—(Procedure A, B, C, and D) Spindles shall conform to the dimensions given in Table 1 and with references to Fig. 1. Spindles made from stainless steel or a composite material that has a lower thermal conductivity. The narrow middle segment shall be ~9.5 mm in length and ~1.8 mm in diameter. In the center of the middle segment will be an immersion mark. The insulated spindle shown in Fig. 1 shall have a gap of ~4 mm in the upper segment, which is covered by a material with poor thermal conduction and pinned to both the upper and lower portions of the upper segment. The gap is to be placed at approximately the mid-point of upper segment. A Brookfield (trademarked) #4B2 conforms to these requirements. The Tannas No. 4 composite spindles⁸ must be

⁸ The sole source of supply of the apparatus known to the committee at this time is Tannas Co., 4800 James Savage Rd., Midland, MI, http://www.savantgroup.com. If you are aware of alternative suppliers, please provide this information to ASTM International Headquarters. Your comments will receive careful consideration at a meeting of the responsible technical committee,¹ which you may attend.

TABLE 1 Spindle Dimensions

	A ^a	B	C	D
Dimension	3.15	3.15	31.1	35.6
Tolerance ±	n/a	0.03	0.1	0.5
All dimensions in mm				

^a Typical dimension.

used in Procedure C. Uninsulated steel spindles (No. 4) shall only be used with the Air Bath Method (Procedure A). An insulated spindle must be used in Procedure D. While uninsulated steel spindles (No. 4) shown, they are not recommended and shall only be used with the Air Bath Method (Procedure A).

6.2.1 When using an insulated steel spindle, such as Brookfield No. 4B2 spindle, ensure that both steel ends are firmly connected to the insulating section. When a slight twist is given to the two metal sections on either side of the insulating cylinder, they should not move relative to each other.

6.2.2 Periodically (depending on use, but at least every 3 months) inspect spindles for run-out (wobble) when attached to the viscometer. The total run-out of the spindle shall not exceed 1 mm (0 mm ± 0.5 mm) when measured at the tip of the spindle.

NOTE 2—It is good laboratory practice to store spindles in a protective manner. Do not leave composite spindles for extended periods in cleaning solvent.

6.3 Test Stator—(Procedures A, B, and C) A glass tube of sufficient diameter to have essentially no influence on the rotation of the spindle compared to the viscous drag of the test fluid even at viscosities above 100 000 mPa·s.

6.3.1 Test Tube Stator—(Procedure A) (See Fig. 2.) A test tube of 25 mm max OD and approximately 115 mm in length, with a fill line indicating approximately 30 mL.

6.3.2 Test Tube Stator—(Procedure B) (See Fig. 2.) A test tube of 25 mm max OD and 115 mm ± 5 mm in length, with a fill mark 47 mm ± 2 mm below the top of the stator. This results in a sample volume of approximately 30 mL.

NOTE 3—Over time, the fill line may become difficult to see. For liquid baths, this is especially important, as it ensures that the stator is filled to a point where the spindle can be properly positioned and have the sample level below the fluid level of the bath.

6.3.3 SimAir Stator⁸—(Procedure C) (See Fig. 2.) The stator portion of a special air sealed cell made for this ASTM method. The inside diameter of this stator is 15 mm minimum with the weld line at 40 mm ± 2 mm below the top of the stator and with a fill mark 51 mm ± 2 mm below the top of the stator. This results in a sample volume of approximately 15 mL. The outside diameter of this stator is 25.3 mm maximum.

NOTE 4—This patented cell (which also includes a composite rotor, keyed connecting device for quick spindle engagement, and cell stopper) simulates the air-bath cooling rate when inserted into a constant temperature liquid bath (see 6.8.2). The keyed connector is not essential to the test but makes spindle attachment faster with fewer disturbances of the sample.

6.4 Cell Stopper—(Procedure A, B, and C) An insulating cap that fits on and into the test cell with a centered hole large enough for the spindle to turn with sufficient clearance to avoid contact with the walls of the centered hole and of a height above the cell that allows a spindle clip to hold the spindle at the proper height in the test fluid during cooling. Suitable dimensions for the stopper are shown in Fig. 3 with tolerances of ±10 % unless otherwise indicated.

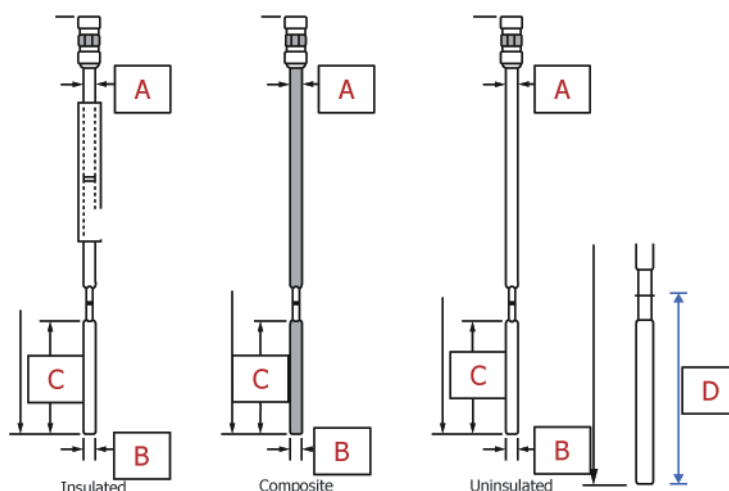

FIG. 1 D2983 Spindles

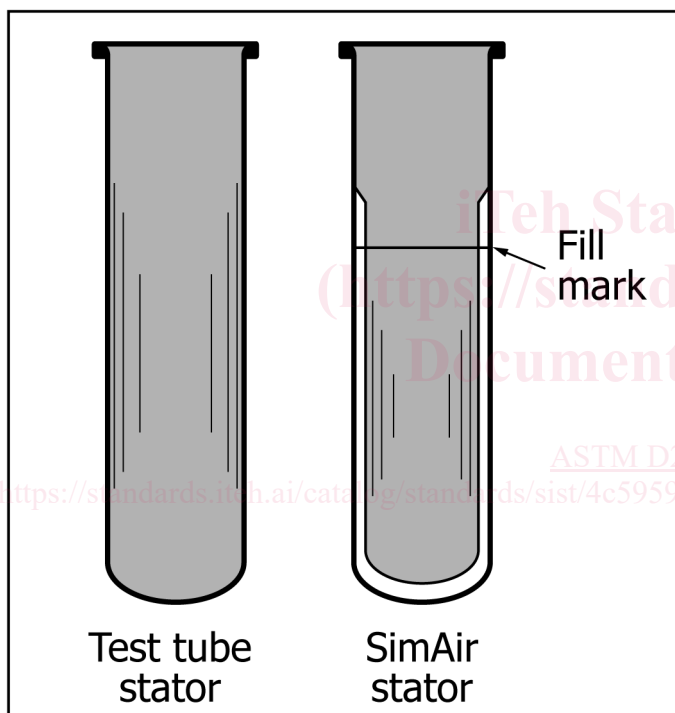

FIG. 2 Diagram of Two Forms of Stators

6.5 *Spindle Clip*—(Procedures A, B, and C) A clip or spacer that lies on top of the cell stopper or is affixed to the spindle and supports the spindle at proper immersion depth during cool-down.

6.6 *Insulated Cell Carrier*—(Procedure A) (Fig. 4.) An insulated container, such as a balsa wood block or similar device, used only with cold-air cabinets to keep the test cell cold during transfer of the test cell from the cold air cabinet to the viscometer and subsequent analysis. Opposing plastic windows in the carrier side walls permit adjustment of the spindle immersion indicator for testing (see 9.4).

6.6.1 When a refrigerated liquid bath is used for final sample soak during the last half hour at analysis temperature,

the insulated cell carrier is also used for sample transfer to the liquid bath and immediately returned to the cold cabinet.

6.7 *Cold-Air Cabinets*—(Procedure A) Mechanically refrigerated cabinets with an air-circulation device and a turntable and rack for samples. The cold cabinet shall be capable of cooling the sample to any chosen test temperature from +5 °C to -40 °C and holding that temperature within ±0.3 °C. Air circulation and the sample turntable shall be able to be switched off prior to fully opening the bath top.

6.7.1 *Turntable*—This motor-driven device is used only in the cold-air cabinets. A cell rack holding the test cells is set on top of the turntable. The turntable shall rotate at a speed of 3 r/min to 5 r/min. This item is often supplied with the cold air cabinet.

6.7.1.1 In the case of the liquid baths, the turntable does not rotate since all samples experience a uniformly stable temperature ensured by the bath medium stirrer.

NOTE 5—To minimize disturbance and loss of cold air, it is recommended that the cabinet has an inner cover with hand-holes for sample insertion in the balsa carrier and removal of the carrier to the point of analysis.

6.8 *Liquid Baths*—(Procedures B and C) Mechanically refrigerated liquid baths are used in two significantly different protocols to gain the same analytical results (see Procedures B and C, respectively, for details).

6.8.1 *Programmable Liquid Baths for Cold-Air Cabinet Cooling Simulation*—Baths capable of closely following the sample cooling in the cold-air bath as outlined in Annex A2.

6.8.1.1 *Glass Caps*—Individual glass covers for each test cell used to cover individual cells when the sample conditioning is in process.

6.8.1.2 *Turntable Cover*—This is an insulated overall cover for the turntable to prevent undue temperature upsets of the samples.

6.8.2 *Constant Temperature Liquid Baths*—Baths used to either condition the sample at the chosen final temperature after cooling in an air cabinet for 15.5 h to that temperature, or as described in Procedure C, used to receive SimAir test cells³ at any time for analysis 16 h after the individual test sample is

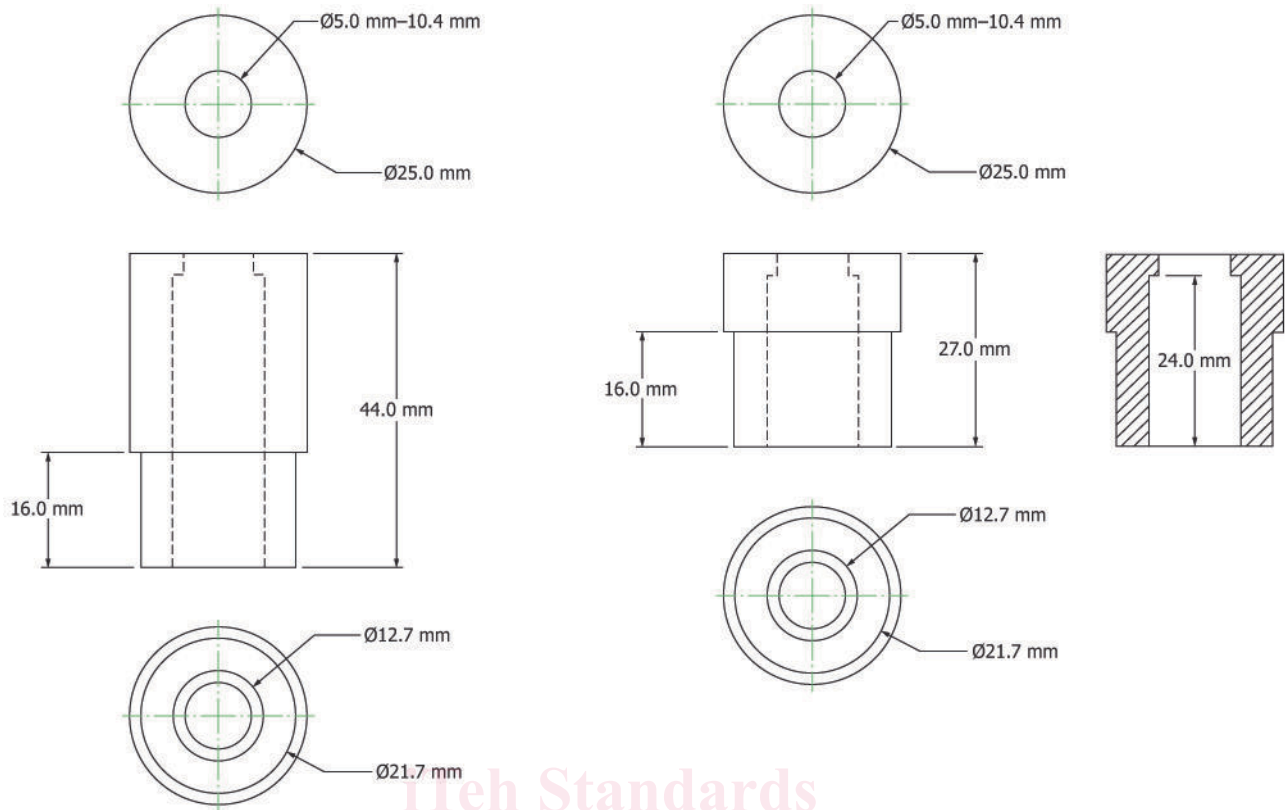
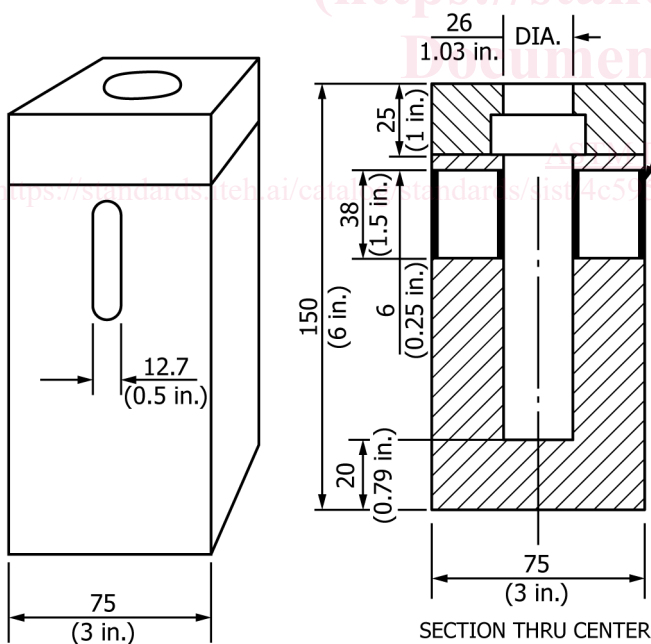

FIG. 3 Cell Stopper for Procedures A, B, C



BALSA WOOD CELL CARRIER

FIG. 4 An Example of an Insulated Cell Carrier

NOTE 6—The SimAir cell³ simulates the cooling curve of the air cabinet, Procedure C.

6.9 Temperature Measuring Device—(Procedures A, B, C, and D) Either a liquid-in-glass thermometer as described in 6.9.1 or a digital contact thermometer (DCT) meeting the requirements described in 6.9.2.

6.9.1 Liquid-in-Glass Thermometer—(Procedures A, B, and C) Use an appropriate thermometer from Table 2.

6.9.2 Digital Contact Thermometer—For Procedures A, B, and C, use D02-DCT11 listed in Specification D8278. For Procedure D, use D02-DCT15 listed in Specification D8278.

NOTE 7—A DCT display/electronics may not function correctly at low temperatures. Consult manual or manufacturer to determine its temperature limitations.

6.9.2.1 The DCT calibration drift shall be checked at least annually by either measuring the ice point or against a reference thermometer in a constant temperature bath at the prescribed immersion depth to ensure compliance with 6.9.2. See Practice D7962.

NOTE 8—When a DCT’s calibration drifts in one direction over several calibration checks, it may be an indication of deterioration of the DCT.

TABLE 2 Calibrating Thermometers (see Specification E1)

IP 94C	–45 °C to –35 °C	ASTM 122C
IP 95C	–35 °C to –25 °C	ASTM 123C
IP 96C	–25 °C to –15 °C	ASTM 124C
IP 97C	–15 °C to –5 °C	ASTM 125C

immersed in the bath. The liquid bath is set at the final temperature and shall be capable of holding the sample at ± 0.1 °C.

6.10 *Thermal Conditioning Unit (TCU) and Viscometer Support*⁹—(Procedure D) The TCU provides an upper mechanism to hold and position the viscometer described in 6.2 over the sample chamber with its spindle centered on the sample chamber. The lower element of the unit contains a thermoelectric temperature controlled chamber that holds the sample tube. Temperature control is by means of a PID programmable controller capable of at least 0.1 °C control over a range from -45 °C to +90 °C. The time and temperature requirements for each test temperature are in Annex A5.

6.11 *Sample Tube*—(Procedure D) A standard laboratory test tube of approximately 25 mm OD and 150 mm in length, preferably without a lip, preferably disposable.

6.12 *Thermometer Holder*—(Procedure D) A sample tube stopper with low thermal conductivity to hold the DCT probe at the correct distance from the top of the sample tube. The stopper consists of two segments. The lower segment is 32 mm ± 2 mm in length and 21 mm ± 2 mm OD. The upper segment is 30 mm ± 2 mm OD and greater than 6 mm in length. The stopper shall include a means of holding the DCT probe at the correct distance from the top of the sample tube. A hole ~3 mm diameter will pass through both segments. An example is shown in Fig. 5.

6.13 *Probe Sheath*—(Procedure D) A tube with low thermal conductivity, such as styrene, ~3 mm OD with a 1.8 mm ID that covers the DCT probe below the top of the thermometer holder to 62 mm from tip of DCT probe.

7. Certified Viscosity Reference Standards (Procedure D)

7.1 *Sample Temperature Calibration Fluid*—A Newtonian fluid that is free of petroleum waxes and has a viscosity certified by a laboratory that has been shown to meet the requirements of ISO 17025 by independent assessment for

⁹ The sole source of supply known to the committee at this time is Cannon Instrument Company, 2139 High Tech Road, State College, PA 16803, www.cannoninstrument.com. If you are aware of alternative suppliers, please provide this information to ASTM International Headquarters. Your comments will receive careful consideration at a meeting of the responsible technical committee,¹ which you may attend.

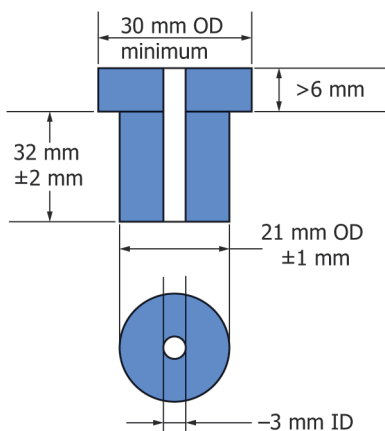

FIG. 5 Sample Tube Stopper

viscosity measurement. Viscosity measurements shall be traceable to master viscometer procedures described in Practice D2162.

7.2 Calibration Fluids—See Table 3.

NOTE 9—It is preferable for the calibration fluids data to include viscosity values at tenth of a degree increments for 0.5 °C above and below the test temperature at which it is used. This minimizes the need to calculate the temperature from the measured viscosity.

8. Procedures A, B, and C: Use of Reference Fluids

8.1 This test method uses metal or composite viscometer spindles described in 6.2 (see Fig. 1). For viscometer heads on which a scale shall be read, these spindles have a table of associated generic conversion factors to permit relatively rapid calculation of the viscosity of an unknown sample. Newer digital viscometers will directly show viscosity and percent full-scale torque using these factors. The generic conversion factors for all spindles are shown in Column 2 of Table 4.

8.2 *Calibration of Spindles*—(See Annex A3 and Annex A4.) For potentially increased accuracy, spindles may be calibrated.

8.2.1 Use of standard reference fluids and technique for calibration is detailed in Annex A3 and Annex A4. This protocol was developed to provide, if desired, an option for more precise determination of the apparent viscosity measurements.

NOTE 10—Although the generic factors of Table 4 provide acceptable results, somewhat greater precision may be generated by this test method by calibrating spindles. Spindle calibration can also indicate problems with the viscometer that require repair to restore accuracy (see Annex A3).

8.2.2 When spindles are calibrated, they must be clearly identified, and the calibration factor must be stored in a traceable manner along with identification of the viscometer used for the calibration. The spindle calibration factor is only valid in combination with the viscometer used for the calibration. If the viscometer undergoes maintenance, repairs, adjustments or calibrations, the spindle calibration factor for that specific viscometer become invalid.

8.2.2.1 Any one spindle may be calibrated for use with several different viscometers. In such instance it must be assured that the correct calibration factor developed for the spindle – viscometer combination is used.

NOTE 11—The spindle calibration factor belongs to one spindle-viscometer combination only. Therefore, diligent logging of spindle identification, calibration factor, viscometer serial number and viscometer

TABLE 3 Calibration Fluids

Test Temperature, °C	Viscosity, mPa·s	Recommended Reference Fluid ⁴
-40.0		CL160
-35.0		CL200
-30.0		CL250
-26.0	9 000 to 14 000	CL280
-20.0		CL380
-12.0		CL600
-10.0		CL680

⁴ While the recommended reference fluids are the same as those used in Test Method D5293, other certified viscosity reference standards that meet the criteria in 7.1 and 7.2 are acceptable.

TABLE 4 Chart for Spindle Speed Selection of Generic Factors

NOTE 1—If determined apparent viscosity is below range indicated for the selected spindle speed, use next higher spindle speed value.

Spindle Speed, r/min	Multiply torque by below number to calculate viscosity at speed selection used	Viscosity Range, mPa·s
0.6	10 000	400 000 to 1 000 000
1.5	4000	200 000 to 400 000
3.0	2000	100 000 to 200 000
6.0	1000	50 000 to 100 000
12.0	500	20 000 to 50 000
30.0	200	9800 to 20 000
60.0	100	1500 to 9800
120.0 ^A	50	250 to 1500

^A 120.0 r/min speed may not be available on some viscometer models.

repairs, adjustments or calibrations are essential to the test accuracy.

8.2.3 Concentricity of the relatively thin spindle for this test method strongly affects the resulting apparent viscosity determination. Consequently, it is recommended to calibrate spindles periodically with reference oil, particularly if run-out is observed.

NOTE 12—Choice of calibration reference oil and the temperature(s) at which it is used is determined by the range of viscosity and temperature required for viscosity determination. Calibration viscosities below 100 000 mPa·s are preferred and easier to use.

8.3 *Specific Use of Reference Oils to Ensure Temperature Control in Cold-Air Cabinets, Procedure A, because of Opening and Closing of the Air Cabinet Lid (Only One Reference Oil Required for Procedures B and C):*

NOTE 13—Opening and closing of the lid of a cold-air cabinet may influence the control of sample temperature and require more time between sample analyses to permit the cabinet temperature to be reestablished so that this is not a problem.

8.3.1 Fill two stators with the proper amount (see 9.2.1) of the same reference fluid and, when loading the sample rack (see 9.2.1), place these at the beginning and end of the sample set.

8.3.2 If, when the sample set is run, the viscosities shown by these two samples are different by more than the repeatability of the method, the discrepancy should be noted and more time allowed between each sample analyzed in subsequent sets.

8.3.3 *Optional Procedure*—Insert a DCT probe (see 6.9.2) in the reference sample. This procedure was used by some (not all) labs running Procedure B during the 2012 round robin study.

Procedure A

9. Procedure A—Cold Air Cabinet

9.1 *Setting the Cold-Air Cabinet Operating Temperature:* There are three different temperatures to consider: the temperature as determined by a blank sample; the cold air cabinet controller temperature; and the temperature as determined from the viscosity result for a reference fluid. Each of these will be discussed below.

9.1.1 *Temperature as Determined by Blank Sample and Associated Cold Air Cabinet Controller Temperature*—With the turntable in proper operating position but turned off, fill a

stator to the required depth with the blank sample (3.2.1) and insert an appropriate temperature measuring device, see 6.9.

9.1.1.1 Place the blank sample in the center of the sample rack (turntable) to monitor temperature.

9.1.1.2 Fill a stator to the required depth with the same reference fluid as the blank sample. Place the stator in the first sample position.

9.1.1.3 Close the cold-air cabinet, turn on the cooling cycle using the temperature controller and allow at least 1 h for the cabinet to come to the test temperature as indicated by the blank sample. If it is difficult to read a thermometer, then a precision digital thermometric device can be used.

9.1.1.4 After the cold-air cabinet temperature indicator has been adjusted to reach and hold the desired temperature of the blank sample, record the indicated temperature shown by the cabinet's temperature controller. This temperature may not completely agree with the blank sample temperature.

9.1.1.5 If a cold-air cabinet temperature adjustment is necessary to bring the blank sample to the desired temperature, it is necessary to allow at least an hour or more for temperature equilibration to be re-established depending on the configuration and capacity of the particular cold-air cabinet.

9.1.2 *Temperature as Determined from Viscosity Result for a Reference Fluid:*

9.1.2.1 When setting up the temperature settings or after major maintenance, determine the viscosity of the reference fluid as per the procedure in Annex A4. Use this to determine an estimate of the apparent temperature at which the reference sample was run. If this temperature is different from the required run temperature, adjust the cabinet temperature controller setting to bring the reference fluid viscosity to within 4 % of its reference value. If this temperature is different from the required run temperature by more than 0.3 °C, then check that all components of the system are operating correctly; especially the analog or digital viscometer. If the air bath is operating correctly, all temperatures should be within 0.3 °C of each other.

NOTE 14—If more than one cold-air cabinet temperature is used for the evaluation of the low-temperature properties of oils in this test method, it will be necessary to determine these cabinet temperature settings as well.

9.2 *Preparation of Sample and Immersion in Cold-Air Cabinet:*

9.2.1 Shake the sample container thoroughly and fill the glass stator to the fill mark (see Fig. 2). If the stator does not have a fill mark, fill with appropriate amount of test oil to permit proper use of the immersion indicator at analysis temperature (approximately 30 mL).

9.2.2 Preheat the test samples in the stator to 50 °C ± 3 °C for 30 min ± 5 min. Protectively cover each sample (such as with aluminum foil or a latex finger cot, etc.) during preheating.

NOTE 15—This preheating step has been proven important in this and other critical low-temperature ASTM test methods. The procedure is designed to remove any memory effects that may develop from previous low-temperature exposures or structure formations.

NOTE 16—Reference fluids do not require pre-conditioning; however, they should be handled in the same manner as the test fluids in all other ways. Annex A4 details the calculation of the apparent run temperature from reference fluid viscosity and r/min data.

9.2.3 It is essential that appropriate reference fluids of the approximate viscosity values be run at the beginning and end of each test series (and results recorded). This will indicate whether there was a change in sample temperature resulting from frequent opening of these cabinets.

9.2.4 If the determined viscosities of these two samples are different by more than the repeatability of the method, the discrepancy should be noted and more time allowed between each sample analyzed in subsequent sets. All samples should be re-run.

9.2.5 Remove the test cells from the pre-heating source and allow them to cool to room temperature and then remove the covers. (Use care in handling the hot stators.)

9.2.6 Place the cell stopper on the stator with the spindle supported by the spindle clip.

9.2.7 The spindle immersion mark (see Fig. 1) should be slightly below the liquid surface (to allow for contraction of the oil sample upon cooling to the temperature of analysis).

NOTE 17—This reduces the amount of sample disturbance before viscosity measurement.

9.2.8 Two samples of each fluid are required.

NOTE 18—There is some susceptibility to sample heating in the process of adjusting the spindle speed for best sensitivity during analysis. For greater accuracy when using cold-air baths and insulated cell carriers, it has become a practice to run two samples of the same fluid; the first to determine best spindle speed, and the second to apply that speed to obtain the viscometric information. Subsequently the second value is chosen.

9.2.9 Place the test cells into the turntable sample rack with a reference fluid sample at the beginning and end of the set of samples. Also place the blank sample (see 3.2.1) in the center position of the rack then place the temperature sensor in it.

9.2.10 Place as many insulated cell carriers (see Fig. 4) within the cold-air cabinet in positions so that they will not unduly restrict airflow around the test samples within the air chamber. Take care to ensure that no insulated cell carrier is placed so it restricts the exit holes for air in the plenum (back wall of air chamber). Close the cabinet lid and turn both the turntable and air blower on.

9.2.11 Cool the samples and insulated cell carriers for 16 h.

9.3 *Using a Liquid Bath for Final Soak and Analysis after Conditioning Samples in an Air-Bath:*

9.3.1 When using a constant temperature liquid bath for the final soak, it is not necessary to use initial and final reference oils as in 9.2.4. Only an initial viscosity value is necessary for analysis and is not to be used to adjust temperature; but to serve as a guide to know if everything is running accurately in the combined system (that is, temperature, viscometer, spindles, etc.). If the viscosity of the reference oil is not within the precision limits, the test shall be repeated with any necessary mechanical corrections made.

9.3.2 Set liquid bath temperature to that desired for final half-hour soak 2 h before using bath. Make certain that the bath temperature is stable using an appropriate temperature measuring device, see 6.9.

9.3.3 For ensuring proper calibration of the final soak liquid bath, it is recommended it be checked that the reference oil transferred from a properly calibrated air chamber give acceptable viscosity values. If the viscosity values are not acceptable,

then the bath temperature should be adjusted and the procedure repeated until acceptable viscosity values are obtained.

9.3.4 Proceed to Section 12 for the setup of the viscometer and selection of spindle speed.

9.4 *Analytical Protocol for Cold-Air Cabinets:*

9.4.1 On completion of the 16 h cold exposure of the samples, check the level of the viscometer to ensure that the drive shaft is vertical (see 12.1) and re-zero (see 12.1.2 to 12.1.3).

9.4.2 Individually transfer and analyze the test samples as follows:

9.4.2.1 Note the cabinet controller temperature. If it is not at the desired temperature as per 9.3.2, adjust the cold-air cabinet. Wait at least 1 h while the cabinet comes to the desired temperature before initiating analysis.

9.4.2.2 Analyze each sample in turn by first turning off the turntable rotation and the air blower. Some cabinets may be designed with a low setting on the blower that can also be used at this time. Different systems may require a different time allowance for shutting off the blower motor and opening the cabinet door. Allow the operator to determine the appropriate time to open the cabinet door.

9.4.2.3 Open the cold-air cabinet and put one temperature-conditioned test cell into a temperature-conditioned insulated cell carrier and remove the now-insulated cell from the cold-air cabinet for analysis. Do not remove more than one sample at a time. Note the temperature of the blank sample; it may not change by more than 0.3 °C when the cabinet is opened.

9.4.2.4 Immediately close the cold-air cabinet lid and restart the turntable and air blower.

9.4.2.5 Transfer the insulated cell carrier and the sample to the viscometer.

9.4.2.6 Place the test cell below the viscometer and align the spindle nut with the viscometer coupling nut. Attach the spindle using a quick attachment device for minimal disturbance of the sample or by screwing the spindle onto the drive shaft thread. Note that this connection is made with a left-handed thread.

9.4.2.7 Remove the spindle clip.

9.4.2.8 Adjust the spindle height by the vertical adjustment knob on the viscometer rack until the spindle immersion indicator (see Fig. 1) is even with the oil level. To facilitate the adjustment of the spindle immersion indicator, place a relatively cool light source, such as a flashlight or diode light, behind one window of the test cell carrier and observe the spindle position through the other.

NOTE 19—Take care to ensure proper depth of spindle immersion with all samples. Maintenance of proper immersion depth is essential to good reproducibility and repeatability. Data have shown that an immersion variation of as little as 1.2 mm from the immersion mark can produce viscosity errors.

9.4.2.9 Center the spindle in the hole at the top of the cell stopper so that no part of the spindle touches the stopper hole during the measurement process.

9.4.2.10 Proceed to Section 12 for the setup of the viscometer and selection of spindle speed.

Procedure B

10. Procedure B: Programmable Liquid Bath

10.1 *Setting the Programmable Liquid Bath Operating Temperature:*

10.1.1 For the programmable liquid bath, the samples are to be loaded into the turntable at a starting temperature as dictated by [Annex A2](#). The software provided with the programmable liquid bath automatically calculates this starting temperature and displays it as the starting setpoint when the test temperature is entered into the software. When the bath has attained the starting temperature, the samples are loaded and the thermal conditioning program is started (see [10.2.9](#)). The software controls the cooling profile as dictated by [Annex A2](#).

10.1.2 *Procedure for Calibrating the Programmable Liquid Bath:*

10.1.2.1 The calibration of the programmable liquid bath is recommended when the instrument is put into service for the first time or after major maintenance. Three samples of the same reference oil of known viscosity are loaded into the turntable at the starting temperature as discussed in [10.2](#) to [10.2.9](#) below. After 1 h the viscosity of the first reference sample is analyzed. If the viscosity values are not in the acceptable range, then the bath set point is suitably adjusted and the next reference sample is analyzed after 1 h. This procedure is repeated until the proper bath temperature offset is obtained. Offset values at various test temperatures may be obtained by this procedure and the value installed in the calibration grid of the software. For future runs, the software automatically finds and applies the pertinent calibrations for the relevant test temperatures.

10.2 *Preparation of Sample and Immersion in a Liquid Programmable Bath:*

10.2.1 Shake the sample container thoroughly and fill the glass stator to the fill mark (see [Fig. 2](#)). If the stator does not have a fill mark, fill with appropriate amount of test oil to permit proper use of the immersion indicator (see [Fig. 1](#)) at analysis temperature. One reference oil sample must be tested for every run to ensure that test conditions are in control according to the test precision.

NOTE 20—Reference fluids do not require pre-conditioning; however, they should be handled in the same manner as the test fluids in all other ways. [Annex A4](#) details the calculation of the apparent run temperature from reference fluid viscosity and spindle speed data.

10.2.2 Preheat the test samples in the stator to $50\text{ }^{\circ}\text{C} \pm 3\text{ }^{\circ}\text{C}$ for $30\text{ min} \pm 5\text{ min}$. Protectively cover each sample (such as with aluminum foil or a latex finger cot, etc.) during preheating.

NOTE 21—This preheating step has been proven to be important in this and other critical low-temperature ASTM test methods. The procedure is designed to remove any memory effects that may develop from previous low-temperature exposures or structure formations.

10.2.3 Remove the test cells from the pre-heating source and allow them to cool to room temperature and then remove the covers. (Use care in handling the hot stators.)

10.2.4 Place the cell stopper on the stator with the spindle supported by the spindle clip.

10.2.5 The spindle immersion mark (see [Fig. 1](#)) should be slightly below the liquid surface (to allow for contraction of the oil sample upon cooling to the temperature of analysis) (see [Fig. 6](#)).

NOTE 22—This reduces the amount of sample disturbance before viscosity measurement.

NOTE 23—Handle and store the spindles and instrument with care at all times. For greatest precision and accuracy, check the calibration of each spindle periodically with reference oil. Do not use any damaged or noticeably bent spindles (see [6.2.2](#)).

10.2.6 On the software screen, select the desired test temperature. The starting temperature is calculated and installed as the setpoint which the bath rapidly attains.

10.2.7 Temperature of the bath shall be monitored by a temperature measuring device suitably placed near the test cells (see [6.9](#)).

10.2.8 When the bath has stabilized at the starting temperature, place preheated and assembled sample-containing test cells in the bath. The remaining positions of the turntable should all be occupied by test cells even if empty. This will ensure that the bath medium will be at the proper level with respect to the samples in the test cell. This ensures proper temperature conditioning of samples. Cover the test cells with the glass caps and then with the turntable cover. Start the cooling profile on the software. One reference oil sample must be tested for every run to ensure that test conditions are in control according to the test precision. If the viscosity of the reference oil is not within the precision limits, the test shall be repeated with any necessary corrections made.

NOTE 24—The test oil level in the test stators must be (at least $\frac{1}{2}$ in. or 12 mm) below the level of the bath medium during temperature conditioning and measurement.

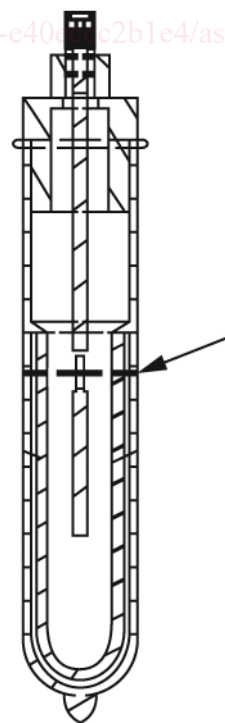

FIG. 6 Correct Immersion of Spindle below Oil Sample Surface