



Designation: **D3917–15a** **D3917 – 23**

## Standard Specification for Dimensional Tolerance of Thermosetting Glass-Reinforced Plastic Pultruded Shapes<sup>1</sup>

This standard is issued under the fixed designation D3917; the number immediately following the designation indicates the year of original adoption or, in the case of revision, the year of last revision. A number in parentheses indicates the year of last reappraisal. A superscript epsilon ( $\epsilon$ ) indicates an editorial change since the last revision or reappraisal.

### 1. Scope\*

1.1 This specification defines production tolerances applicable to standard rods, bars, shapes, and flat sheet pultruded from thermosetting glass-reinforced plastics.

1.2 These dimensional tolerances apply to all shapes specified as “standard” by the pultrusion industry.

1.3 Custom shapes and products designed for special applications may carry specific tolerances that vary from the standard.

1.4 The values stated in inch-pound units are to be regarded as standard. The values given in parentheses are mathematical conversions to SI units that are provided for information only and are not considered standard.

1.5 The following safety hazards caveat pertains only to the test methods portion, Section 4.5, of this specification: *This standard does not purport to address all of the safety concerns, if any, associated with its use. It is the responsibility of the user of this standard to establish appropriate safety and health, safety, health, and environmental practices and determine the applicability of regulatory limitations prior to use.*

NOTE 1—There is no known ISO equivalent to this standard.

1.6 *This international standard was developed in accordance with internationally recognized principles on standardization established in the Decision on Principles for the Development of International Standards, Guides and Recommendations issued by the World Trade Organization Technical Barriers to Trade (TBT) Committee.*

### 2. Referenced Documents

#### 2.1 ASTM Standards:<sup>2</sup>

[D883 Terminology Relating to Plastics](#)

### 3. Terminology

#### 3.1 Definitions:

3.1.1 *camber*—the deviation of the edge or surface from a reference straight line with the weight of the pultrusion not minimizing the measurement.

<sup>1</sup> This specification is under the jurisdiction of ASTM Committee D20 on Plastics and is the direct responsibility of Subcommittee D20.18 on Reinforced Thermosetting Plastics.

Current edition approved Oct. 1, 2015; Nov. 1, 2023. Published October 2015; November 2023. Originally approved in 1980. Last previous edition approved in 2015 as D3917–15; D3917–15a. DOI: 10.1520/D3917-15A; 10.1520/D3917-23.

<sup>2</sup> For referenced ASTM standards, visit the ASTM website, [www.astm.org](http://www.astm.org), or contact ASTM Customer Service at [service@astm.org](mailto:service@astm.org). For *Annual Book of ASTM Standards* volume information, refer to the standard's Document Summary page on the ASTM website.

\*A Summary of Changes section appears at the end of this standard

3.1.2 *flat sheet*—a rectangular solid pultruded profile with a width of 12 in. up to and including 78 inches.

3.1.3 *mean wall thickness*—the average of two or more wall thickness measurements taken at multiple locations.

3.1.4 *straightness*—the upward deviation of a pultruded shape when resting on a flat surface measured in a manner that the weight of the pultruded part minimizes the deviation.

3.2 For definitions or terms that are not defined in this standard, refer to Terminology [D883](#).

**iTeh Standards**  
**(<https://standards.iteh.ai>)**  
**Document Preview**

[ASTM D3917-23](#)

<https://standards.iteh.ai/catalog/standards/sist/f0f862ab-999b-4fc9-b4c8-2ea17d02028d/astm-d3917-23>

4. Dimensional Criteria

4.1 Cross-sectional dimensions for standard rods, bars, and shapes shall be prescribed in Table 1.

4.1.1 For die struck dimension, if the calculated tolerance as per above table is more than 0.094 in. (2.39 mm), then the die struck dimension tolerance shall be ±0.094 in. (2.39 mm).

4.1.2 For wall thickness of open shapes and closed shapes and flatsheets of thickness under 0.125 in. (3.175 mm) dimensions, if the calculated tolerance as per above table is less than 0.01 in. (0.25 mm), the thickness tolerance shall be ±0.01 in. (0.25 mm).

4.1.3 For wall thickness and flatsheets of thickness over 0.125 in. (3.175 mm) dimensions, if the calculated tolerance as per above table is more than 0.05 in. (1.27 mm), the thickness tolerance shall be ±0.05 in. (1.27 mm).

4.2 Length tolerances for standard rods, bars, and shapes shall be as prescribed in Table 2.

4.3 Straightness tolerances shall be as prescribed in Table 3 (also see 4.25.2).

TABLE 1 Cross-Sectional Dimensions—Standard Rods, Bars, and Shapes

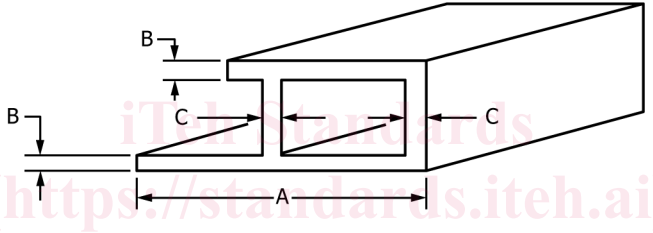

A Die Struck Dimension <sup>A, B</sup>	B Wall Thickness <sup>B</sup> (Open Shape)	Solid Dimensions, ±in. (mm)		C Wall Thickness <sup>B</sup> (Closed Shape)
		Thickness (Flat Sheets)		
		Thickness 0.125 (3.175) and under	Thickness over 0.125 (3.175)	
±4 % 0.094 (2.39) max	±10 % ±0.010 (0.25) min	±15 % ±0.010 (0.25) min	±10 % ±0.050 (1.27) max	±20 % ±0.010 (0.25) min

<sup>A</sup>The outside dimension of a part.

<sup>B</sup>Standard pultruded section with dimension up to 36-in. (914-mm) diameter.

TABLE 2 Length—Standard Rods, Bars, Shapes, and Flat Sheet

	Allowable Deviation from Specified Length, +, - in. (+, - mm), except as noted		
	Length up to 8 ft (2.44 m) inclusive	Length over 8 to 24 ft (2.44 to 7.32 m) inclusive	Length over 24 ft (7.32 m)
	All Rods, Bars, and Shapes	+0.25, -0 (+6.35, -0)	+0.5, -0 (+12.7, -0)

TABLE 3 Straightness<sup>A</sup>—Standard Bars, Rods, Shapes, and Flat Sheet

Product	Specified Diameter (Rods) Specified Width (Bars) Max Dimension (Shapes)	Specified Thickness (Rectangles) Minimum Thickness (Shapes)	Allowable Deviation (D) from Straight, in. (mm)	
			In. (mm)	In Total Length of Piece
Rods and square, hexagonal, and octagonal bars	all	...	0.030 (2.5) × length, ft (m)	
Rectangular bars	Up to 1.499 (38.07), incl	Up to 0.094 (2.4), incl	0.050 (4.17) × measured length, ft (m)	

