



Designation: **F3394/F3394M—20 F3394/F3394M – 23**

## Standard Specification for Hardened Steel Backup and Reaction Washers Inch and Metric Dimensions<sup>1,2</sup>

This standard is issued under the fixed designation F3394/F3394M; the number immediately following the designation indicates the year of original adoption or, in the case of revision, the year of last revision. A number in parentheses indicates the year of last reapproval. A superscript epsilon ( $\epsilon$ ) indicates an editorial change since the last revision or reapproval.

### 1. Scope

1.1 This specification covers the chemical, mechanical, and dimensional requirements for hardened steel Backup and Reaction washers for use with fasteners having nominal diameters of ½ in. through 3 in. and M14 through M80. These washers are intended for general-purpose mechanical and structural use with bolts, nuts, studs, DTIs, and other internally and externally threaded fasteners. These washers are suitable for use with fasteners covered in Specifications [A354](#), [A193/A193M](#), [A194/A194M](#), [A320/A320M](#), [F959/F959M](#), [A449](#), [A563](#), [A563M](#), and [F3125](#).

1.2 The washers are designated by *style* denoting the shape, by *type* denoting the material, and by inch or metric dimensions.

1.2.1 The styles of washers covered are:

1.2.1.1 *Reaction*—Circular washers with a knurled surface on one side and a contoured outside diameter designed to couple with the installation tool.

1.2.1.2 *Backup*—Circular washers having a knurled surface on both sides.

1.2.2 The types of washers covered are:

1.2.2.1 *Type 1*—Medium Carbon or Medium Carbon Alloy Steel.

1.2.2.2 *Type 3*—Weathering steel. This specification provides for furnishing Type 3 to chemical composition or a Corrosion Index (CRI) of 6 or higher, at the supplier's option.

1.3 The values stated in either inch-pound units for inch fasteners and SI units for metric fasteners and are to be regarded separately as standard. The values stated in each system may not be exact equivalents; therefore, each system shall be used independently of the other. Combining values from the two systems may result in non-conformance with the standard.

1.4 *This standard does not purport to address all of the safety concerns, if any, associated with its use. It is the responsibility of the user of this standard to establish appropriate safety, health, and environmental practices and determine the applicability of regulatory limitations prior to use.*

<sup>1</sup> This specification is under the jurisdiction of ASTM Committee [F16](#) on Fasteners and is the direct responsibility of Subcommittee [F16.06](#) on Steel Washers and Rivets. Current edition approved ~~Jan. 1, 2020~~ Nov. 15, 2023. Published ~~March 2020~~ November 2023. Originally approved in 2020. Last previous edition approved in 2020 as [F3394/F3394M – 20](#). DOI: ~~10.1520/F3394-2010.1520/F3394-23~~.

<sup>2</sup> Backup and Reaction washers of the type covered by this standard have a patent application pending. Interested parties are invited to submit information regarding the identification of an alternative(s) to these patent-pending items to the ASTM International Headquarters. Your comments will receive careful consideration at a meeting of the responsible technical committee, which you may attend

1.5 This international standard was developed in accordance with internationally recognized principles on standardization established in the Decision on Principles for the Development of International Standards, Guides and Recommendations issued by the World Trade Organization Technical Barriers to Trade (TBT) Committee.

## 2. Referenced Documents

### 2.1 ASTM Standards:<sup>3</sup>

**A193/A193M** Specification for Alloy-Steel and Stainless Steel Bolting for High Temperature or High Pressure Service and Other Special Purpose Applications

**A194/A194M** Specification for Carbon Steel, Alloy Steel, and Stainless Steel Nuts for Bolts for High Pressure or High Temperature Service, or Both

**A320/A320M** Specification for Alloy-Steel and Stainless Steel Bolting for Low-Temperature Service

**A354** Specification for Quenched and Tempered Alloy Steel Bolts, Studs, and Other Externally Threaded Fasteners

**A449** Specification for Hex Cap Screws, Bolts and Studs, Steel, Heat Treated, 120/105/90 ksi Minimum Tensile Strength, General Use

**A563** Specification for Carbon and Alloy Steel Nuts

**A563M** Specification for Carbon and Alloy Steel Nuts (Metric) (Withdrawn 2021)<sup>4</sup>

**A588/A588M** Specification for High-Strength Low-Alloy Structural Steel, up to 50 ksi [345 MPa] Minimum Yield Point, with Atmospheric Corrosion Resistance

**A751** Test Methods and Practices for Chemical Analysis of Steel Products

**A1059** Specification for Zinc Alloy Thermo-Diffusion Coatings (TDC) on Steel Fasteners, Hardware, and Other Products

**B695** Specification for Coatings of Zinc Mechanically Deposited on Iron and Steel

**D769** Specification for Black Synthetic Iron Oxide

**F606/F606M** Test Methods for Determining the Mechanical Properties of Externally and Internally Threaded Fasteners, Washers, Direct Tension Indicators, and Rivets

**F959/F959M** Specification for Compressible-Washer-Type Direct Tension Indicators for Use with Structural Fasteners, Inch and Metric Series

**F1136/F1136M** Specification for Zinc/Aluminum Corrosion Protective Coatings for Fasteners

**F1470** Practice for Fastener Sampling for Specified Mechanical Properties and Performance Inspection

**F1789** Terminology for F16 Mechanical Fasteners

**F2833** Specification for Corrosion Protective Fastener Coatings with Zinc Rich Base Coat and Aluminum Organic/Inorganic Type

**F3019** Specification for Chromium Free Zinc-Flake Composite, with or without Integral Lubricant, Corrosion Protective Coatings for Fasteners

**F3125** Specification for High Strength Structural Bolts and Assemblies, Steel and Alloy Steel, Heat Treated, Inch Dimensions 120 ksi and 150 ksi Minimum Tensile Strength, and Metric Dimensions 830 MPa and 1040 MPa Minimum Tensile Strength

**G101** Guide for Estimating the Atmospheric Corrosion Resistance of Low-Alloy Steels

### 2.2 ISO Standards:<sup>5</sup>

**ISO 11408** Chemical conversion coatings — Black oxide coating on iron and steel — Specification and test methods

## 3. Terminology

3.1 Terms used in this specification are defined in Terminology **F1789** unless otherwise defined herein.

## 4. Ordering Information

4.1 Orders under this specification shall include the following:

4.1.1 Quantity (number of pieces),

4.1.2 Style (Reaction Washer, Backup Washer, see **1.2.1**),

4.1.3 Type (see **1.2.2**),

<sup>3</sup> For referenced ASTM standards, visit the ASTM website, [www.astm.org](http://www.astm.org), or contact ASTM Customer Service at [service@astm.org](mailto:service@astm.org). For *Annual Book of ASTM Standards* volume information, refer to the standard's Document Summary page on the ASTM website.

<sup>4</sup> The last approved version of this historical standard is referenced on [www.astm.org](http://www.astm.org).

<sup>5</sup> Available from International Organization for Standardization (ISO), ISO Central Secretariat, BIBC II, Chemin de Blandonnet 8, CP 401, 1214 Vernier, Geneva, Switzerland, <http://www.iso.org>.

- 4.1.4 Size, that is, nominal diameter,
- 4.1.5 ASTM designation and year of issue (if not specified, current issue shall be used),
- 4.1.6 Coating type, if required (see 5.3),
- 4.1.7 Source inspection, if required (see Section 12),
- 4.1.8 Test reports, if required (see Section 14), and
- 4.1.9 Any special requirements.

## 5. Materials and Manufacture

5.1 Steel used in the manufacture of Reaction and Backup washers shall be produced by the open-hearth, basic-oxygen, or electric-furnace process.

5.2 Backup and Reaction Washers shall be through-hardened by heating to a temperature above the upper transformation temperature, quenching in a liquid medium, and tempering by reheating to not less than 800 °F/427 °C. Alloy steel washers shall be quenched in oil.

### 5.3 Protective Coatings:

5.3.1 Unless otherwise specified, washers shall be furnished “plain” with the “as-fabricated” surface finish without protective coatings.

5.3.2 When zinc-coated washers are required, the purchaser shall specify the zinc coating process, for example, thermodiffusion, mechanically deposited, Zinc/Aluminum Corrosion Protective Coating, or no preference.

5.3.2.1 When thermo-diffusion is specified the washers shall be zinc coated by the thermo-diffusion process in accordance with the requirements of Class 25 of Specification **A1059**.

5.3.2.2 When mechanically deposited is specified the washers shall be zinc coated by the mechanical-deposition process in accordance with the requirements of Class 55 of Specification **B695**.

5.3.2.3 When Zinc/Aluminum Corrosion Protective Coating is specified, the washers shall be coated in accordance with the requirements of Grade 3 of Specification **F1136/F1136M**, Grade 1 of Specification **F2833**, or Grade 4 of Specification **F3019**.

5.3.3 When black oxide is specified the washers shall be black oxide treated in accordance with the requirements of Specification **D769** or ISO 11408.

5.3.4 Other coatings or surface finishes are to be used only when approved by the manufacturer.

### 5.4 Secondary Processing:

5.4.1 Lot control and full traceability shall be maintained throughout all outside and secondary processes.

5.4.2 If washers are heat-treated or coated by a subcontractor, they shall be returned to the manufacturer for testing prior to shipment to the purchaser.

## 6. Chemical Composition

6.1 Type 1 washers shall conform to the chemical composition specified in **Table 1**.

6.2 Type 3 washers shall conform to the heat analysis specified in **Table 1**.

TABLE 1 Chemical Requirements<sup>A</sup>

Element	Composition	
	Type 1 <sup>B</sup>	Type 3 <sup>C</sup>
Carbon		
Heat analysis	0.30 – 0.57	0.30 – 0.57
Product analysis	0.28 – 0.59	0.28 – 0.59
Phosphorus, max		
Heat analysis	0.040	0.040
Product analysis	0.050	0.045
Sulfur, max		
Heat analysis	0.050	0.050
Product analysis	0.060	0.055
Silicon		
Heat analysis	...	0.15–0.35
Product analysis	...	0.13–0.37
Chromium		
Heat analysis	...	0.45–0.65
Product analysis	...	0.42–0.68
Nickel		
Heat analysis	...	0.25–0.45
Product analysis	...	0.22–0.48
Copper		
Heat analysis	...	0.25–0.45
Product analysis	...	0.22–0.48

<sup>A</sup> When providing Weathering Steels to a calculated corrosion index use the Legault-Leckie formula from Guide G101. Link to online calculator: [http://www.astm.org/COMMIT/G01\\_G101Calcu1100.xls](http://www.astm.org/COMMIT/G01_G101Calcu1100.xls)

$$I = 26.01 (\% Cu) + 3.88 (\% Ni) + (\% Cr) + 1.49 (\% Si) + 17.28 (\% P) - 7.29 (\% Cu) (\% Ni) - 9.10 (\% Ni) (\% P) - 33.39 (\% Cu)^2$$

<sup>B</sup> Steel, as defined by the American Iron and Steel Institute, shall be considered to be alloy when the maximum range given for the content of alloying elements exceeds one or more of the following limits: Manganese, 1.65 %; silicon, 0.60 %; copper, 0.60 % or in which a definite range or a definite minimum quantity of any of the following elements is specified or required within the limits of the recognized field of constructional alloy steels: aluminum, chromium up to 3.99 %, cobalt, columbium, molybdenum, nickel, titanium, tungsten, vanadium, zirconium, or any other alloying elements added to obtain a desired alloying effect.

<sup>C</sup> Weathering steel washers may also be manufactured from any of the steels listed in Table 2 of Specifications A588/A588M and F3125.

## ASTM F3394/F3394M-23

<https://standards.iteh.ai/catalog/standards/sist/9e1b892b-489c-4d9c-a22d-f14ce40f93ef/astm-f3394-f3394m-23>

6.2.1 Alternatively, at the supplier's option, Type 3 washers having a Copper minimum Heat Analysis of 0.25 %, Phosphorous and Sulfur conforming to Table 1 and a Corrosion Index of 6 or higher as calculated from the Heat Analysis as described in Guide G101 Predictive method based on the data of Larabee and Coburn, or the predictive method based upon the data of Townsend, shall be accepted.

6.2.2 Product Analysis are not applicable to Type 3 washers furnished to a CRI of 6 or higher calculated from the Heat Analysis.

6.3 For Type 1 and Type 3 washers furnished to the Chemical Compositions in Table 1, Product Analysis of finished washers representing each lot shall conform to the requirements for Chemical Composition in Table 1, Product Analysis.

6.4 Chemical analyses shall be performed in accordance with Test Methods, Practices, and Terminology A751.

## 7. Mechanical Properties

7.1 All Backup and Reaction Washers shall be through-hardened to a hardness of 38 to 45 HRC.

## 8. Dimensions and Tolerances

8.1 Reaction washers, as shown in Fig. 1, shall conform to the dimensions shown in Table 2 (inch series washers) or Table 3 (metric series washers). Backup washers, as shown in Fig. 2, shall conform to the dimensions shown in Table 4 (inch series washers) and Table 5 (metric series washers).

8.1.1 *Contoured Outside Diameter*—The outer edge located between the Bearing Diameter (BD) and the Outside Diameter (OD)

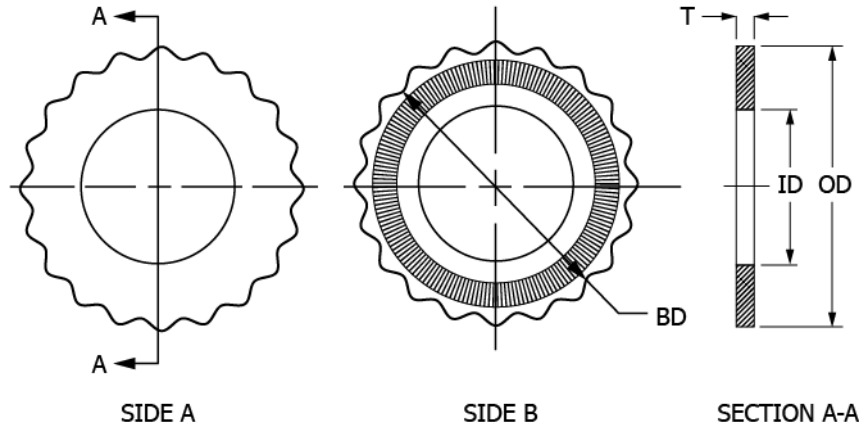

FIG. 1 Reaction Washer

TABLE 2 Reaction Washer Dimensions (Inch Series)

Nominal	Inside Diameter <sup>A</sup> (ID) Inches		Outside Diameter (OD) Inches		Thickness (T) Inches		Bearing Diameter (BD) Inches	
	min	max	min	max	min	max	min	max
1/2	0.520	0.600	1.00	1.20	0.097	0.180	0.90	1.10
9/16	0.585	0.700	1.10	1.30	0.110	0.180	1.00	1.20
5/8	0.651	0.800	1.30	1.50	0.122	0.180	1.10	1.30
3/4	0.783	0.900	1.50	1.70	0.122	0.220	1.30	1.50
7/8	0.914	1.000	1.70	2.00	0.136	0.220	1.50	1.70
1	1.043	1.200	1.90	2.20	0.136	0.220	1.70	1.90
1 1/8	1.174	1.400	2.20	2.50	0.158	0.260	2.00	2.30
1 1/4	1.306	1.500	2.40	2.70	0.158	0.260	2.10	2.40
1 3/8	1.437	1.600	2.60	2.90	0.158	0.260	2.30	2.60
1 1/2	1.568	1.700	2.80	3.10	0.158	0.260	2.50	2.80
1 5/8	1.693	1.800	3.00	3.30	0.158	0.320	2.70	3.00
1 3/4	1.818	1.900	3.30	3.60	0.178	0.320	3.00	3.30
1 7/8	1.943	2.100	3.60	3.80	0.178	0.320	3.20	3.50
2	2.068	2.300	3.70	4.00	0.178	0.320	3.30	3.70
2 1/4	2.318	2.500	4.20	4.50	0.240	0.400	3.80	4.20
2 1/2	2.568	2.800	4.60	4.90	0.240	0.430	4.20	4.60
2 3/4	2.818	3.000	5.10	5.40	0.240	0.430	4.60	5.00
3	3.068	3.300	5.40	5.70	0.240	0.500	5.00	5.40

<sup>A</sup> The referee method for determination of inside diameter shall be use of go/no-go plug gauges of class XX or better.

<https://standards.iteh.ai/catalog/standards/sist/9e1b892b-489c-4d9c-a22d-f14ce40f93ef/astm-f3394-f3394m-23>

shall be designed to couple with the reaction surface of the installation tool. For washers having an odd number of projections, the Outside Diameter shall be the diameter of the circle scribed such that it traverses through the peaks of the projections.

8.1.2 *Knurled Surfaces:*

8.1.2.1 Knurls shall be located between the Inside Diameter (ID) and the Bearing Diameter (BD) on Reaction Washers.

8.1.2.2 Knurls shall be located between the Inside Diameter (ID) and the Outside Diameter (OD) on Backup Washers.

8.1.2.3 The maximum spacing between knurls shall be 0.1 in. for inch-series washers and 2.5 mm for metric-series washers.

8.1.2.4 The minimum height for knurls is 0.005 in. for inch-series washers and 0.125 mm for metric-series washers.

8.1.2.5 The maximum height for knurls shall be included in the determination of the overall thickness (T).

8.1.3 *Flatness, Concentricity, and Burrs*—Tolerances for flatness, concentricity, and burrs shall be in accordance with Table 6.

8.1.4 All dimensions are as-formed, prior to the application of coating or plating, or both.

9. **Workmanship, Finish, and Appearance**

9.1 The washers shall be free of injurious material or manufacturing defects that would affect their performance. All washers shall be free of excessive burrs and sharp edges. (see Table 6).

TABLE 3 Reaction Washer Dimensions (Metric Series)

Nominal	Inside Diameter (ID) <sup>A</sup> Millimeters		Outside Diameter (OD) Millimeters		Thickness (T) Millimeters		Bearing Diameter (BD) Millimeters	
	min	max	min	max	min	max	min	max
M14	14.50	17.00	27.0	30.0	3.1	4.0	24.0	27.0
M16	16.50	19.00	30.0	33.0	3.1	4.0	26.0	29.0
M18	18.50	21.00	35.0	38.0	3.1	4.0	29.0	32.0
M20	20.50	23.00	36.0	39.0	3.1	4.0	32.0	35.0
M22	23.00	26.00	39.0	42.0	3.4	4.0	35.0	38.0
M24	25.00	28.00	45.0	48.0	3.4	5.0	40.0	44.0
M27	28.00	31.00	50.0	53.0	4.0	5.0	44.0	48.0
M30	31.00	34.00	56.0	59.0	4.0	6.0	51.0	55.0
M33	34.00	37.00	61.0	64.0	4.0	7.0	54.0	58.0
M36	37.00	40.00	67.0	70.0	4.0	7.0	60.0	64.0
M39	40.00	43.00	72.0	75.0	4.0	7.0	65.0	69.0
M42	43.00	46.00	78.0	82.0	4.6	8.0	71.0	76.0
M45	46.00	49.00	83.0	87.0	4.6	8.0	77.0	82.0
M48	49.00	52.00	90.0	94.0	4.6	8.0	83.0	88.0
M52	53.00	56.00	94.0	98.0	4.6	8.0	87.0	92.0
M56	57.00	61.00	106.0	110.0	6.1	9.0	98.0	103.0
M60	61.00	66.00	106.0	110.0	6.1	9.0	98.0	103.0
M64	65.00	70.00	118.0	122.0	6.1	11.0	108.0	113.0
M68	69.00	74.00	118.0	122.0	6.1	11.0	108.0	113.0
M72	73.00	78.00	130.0	134.0	6.1	11.0	118.0	123.0
M76	77.00	82.00	130.0	134.0	6.1	11.0	118.0	123.0
M80	81.00	86.00	138.0	144.0	6.1	14.0	126.0	132.0

<sup>A</sup> The referee method for determination of inside diameter shall be use of go/no-go plug gauges of class XX or better

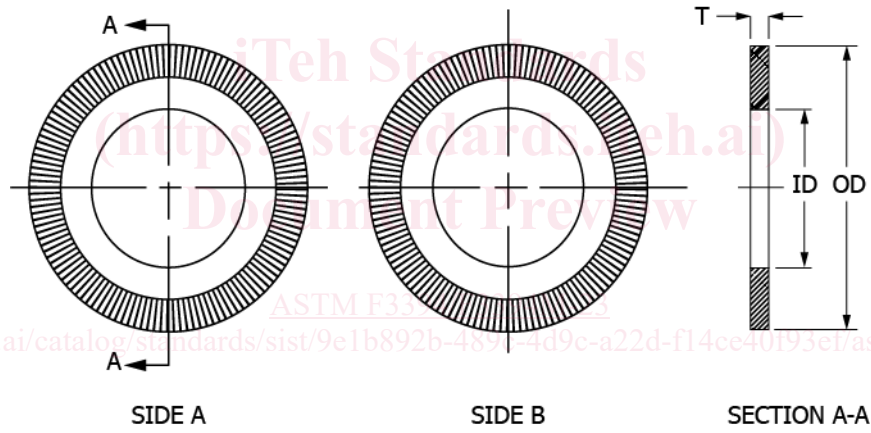

10. Number of Test and Retests

10.1 Responsibility:

10.1.1 The manufacturer shall inspect and test each lot of washers prior to shipment in accordance with the lot control/quality assurance procedures described in 10.2 through 10.4.

10.1.2 When supplied by a source other than the manufacturer or processed by an outside supplier, the responsible party shall ensure that all tests have been performed and the washers conform to this specification.

10.2 Production Lot Method:

10.2.1 All Reaction and Backup washers shall be processed in accordance with a lot identification control—quality assurance plan. The manufacturer shall identify and maintain the integrity of each production lot of washers from raw material selection through all processing operations and treatments to final packing and shipment. Each lot shall be assigned its own lot identification number, each lot shall be inspected and tested, and the inspection and test reports for each lot shall be retained.