



Designation: E740/E740M – 23

Standard Practice for Fracture Testing with Surface-Crack Tension Specimens¹

This standard is issued under the fixed designation E740/E740M; the number immediately following the designation indicates the year of original adoption or, in the case of revision, the year of last revision. A number in parentheses indicates the year of last reapproval. A superscript epsilon (ϵ) indicates an editorial change since the last revision or reapproval.

1. Scope

1.1 This practice covers the design, preparation, and testing of surface-crack tension (SCT) specimens. It relates specifically to testing under continuously increasing force and excludes cyclic and sustained loadings. The quantity determined is the residual strength of a specimen having a semielliptical or circular-segment fatigue crack in one surface. This value depends on the crack dimensions and the specimen thickness as well as the characteristics of the material.

1.2 Metallic materials that can be tested are not limited by strength, thickness, or toughness. However, tests of thick specimens of tough materials may require a tension test machine of extremely high capacity. The applicability of this practice to nonmetallic materials has not been determined.

1.3 This practice is limited to specimens having a uniform rectangular cross section in the test section. The test section width and length must be large with respect to the crack length. Crack depth and length should be chosen to suit the ultimate purpose of the test.

1.4 Residual strength may depend strongly upon temperature within a certain range depending upon the characteristics of the material. This practice is suitable for tests at any appropriate temperature.

1.5 Residual strength is believed to be relatively insensitive to loading rate within the range normally used in conventional tension tests. When very low or very high rates of loading are expected in service, the effect of loading rate should be investigated using special procedures that are beyond the scope of this practice.

NOTE 1—Further information on background and need for this type of test is given in the report of ASTM Task Group E24.01.05 on Part-Through-Crack Testing (1).²

1.6 The values stated in either SI units or inch-pound units are to be regarded separately as standard. The values stated in

¹ This practice is under the jurisdiction of ASTM Committee E08 on Fatigue and Fracture and is the direct responsibility of Subcommittee E08.07 on Fracture Mechanics.

Current edition approved Nov. 15, 2023. Published December 2023. Originally approved in 1988. Last previous edition approved in 2016 as E740/E740M – 03(2016). DOI: 10.1520/E0740_E0740M-23.

² The boldface numbers in parentheses refer to the list of references at the end of this standard.

each system may not be exact equivalents; therefore, each system shall be used independently of the other. Combining values from the two systems may result in non-conformance with the standard.

1.7 *This standard does not purport to address all of the safety concerns, if any, associated with its use. It is the responsibility of the user of this standard to establish appropriate safety, health, and environmental practices and determine the applicability of regulatory limitations prior to use.*

1.8 *This international standard was developed in accordance with internationally recognized principles on standardization established in the Decision on Principles for the Development of International Standards, Guides and Recommendations issued by the World Trade Organization Technical Barriers to Trade (TBT) Committee.*

2. Referenced Documents

2.1 *ASTM Standards:*³

E4 Practices for Force Calibration and Verification of Testing Machines

E8/E8M Test Methods for Tension Testing of Metallic Materials

E338 Test Method of Sharp-Notch Tension Testing of High-Strength Sheet Materials (Withdrawn 2010)⁴

E399 Test Method for Linear-Elastic Plane-Strain Fracture Toughness of Metallic Materials

E466 Practice for Conducting Force Controlled Constant Amplitude Axial Fatigue Tests of Metallic Materials

E561 Test Method for K_{R} Curve Determination

E1823 Terminology Relating to Fatigue and Fracture Testing

3. Terminology

3.1 *Definitions:*

3.1.1 Definitions given in Terminology E1823 are applicable to this practice.

3.1.2 *crack mouth opening displacement (CMOD)*, $2v_m$ (L)—crack—opening displacement resulting from the total

³ For referenced ASTM standards, visit the ASTM website, www.astm.org, or contact ASTM Customer Service at service@astm.org. For *Annual Book of ASTM Standards* volume information, refer to the standard's Document Summary page on the ASTM website.

⁴ The last approved version of this historical standard is referenced on www.astm.org.

deformation (elastic plus plastic) measured under force at the location on the crack surface that has the largest displacement per unit force.

NOTE 2—In surface-crack tension (SCT) specimens, CMOD is measured on the specimen surface along the normal bisector of the crack length.

3.1.3 *fracture toughness*—a generic term for measures of resistance to extension of a crack.

3.1.4 *original crack size, a_o [L]*—the physical crack size at the start of testing.

3.2 *Definitions of Terms Specific to This Standard:*

3.2.1 *crack depth, a [L]*—in surface-crack tension (SCT) specimens, the normal distance from the cracked plate surface to the point of maximum penetration of the crack front into the material. Crack depth is a fraction of the specimen thickness.

3.2.1.1 *Discussion*—In this practice, crack depth is the original depth a_o and the subscript o is everywhere implied.

3.2.2 *crack length, $2c$ [L]*—in surface-crack tension specimens, a distance measured on the specimen surface between the two points at which the crack front intersects the specimen surface. Crack length is a fraction of specimen width.

3.2.2.1 *Discussion*—In this practice, crack length is the original length $2c_o$ and the subscript o is everywhere implied.

3.2.3 *residual strength, σ_r (FL^{-2})*—the maximum value of the nominal stress, neglecting the area of the crack, that a cracked specimen is capable of sustaining.

NOTE 3—In surface-crack tension (SCT) specimens, residual strength is the ratio of the maximum load (P_{max}) to the product of test section width (W) times thickness (B), $P_{max}/(BW)$. It represents the stress at fracture normal to and remote from the plane of the crack.

4. Significance and Use

4.1 The surface-crack tension (SCT) test is used to estimate the load-carrying capacity of simple sheet- or plate-like structural components having a type of flaw likely to occur in service. The test is also used for research purposes to investigate failure mechanisms of cracks under service conditions.

4.2 The residual strength of an SCT specimen is a function of the crack depth and length and the specimen thickness as well as the characteristics of the material. This relationship is extremely complex and cannot be completely described or characterized at present.

4.2.1 The results of the SCT test are suitable for direct application to design only when the service conditions exactly parallel the test conditions. Some methods for further analysis are suggested in [Appendix X1](#).

4.3 In order that SCT test data can be comparable and reproducible and can be correlated among laboratories, it is essential that uniform SCT testing practices be established.

4.4 The specimen configuration, preparation, and instrumentation described in this practice are generally suitable for cyclic- or sustained-force testing as well. However, certain constraints are peculiar to each of these tests. These are beyond the scope of this practice but are discussed in Ref. (1).

5. Apparatus

5.1 The procedure involves testing of specimens that have been precracked in fatigue. force versus CMOD, if CMOD is measured, is recorded autographically or digitally.

5.2 *Fatigue Precracking Apparatus*—Axial tension or three-point, four-point, or cantilever bending are all acceptable modes for fatigue precracking. Fixture design is not critical as long as the crack growth is symmetrical and the plane of the crack remains perpendicular to the specimen face and the tensile force vector. The effect of cyclic frequency is thought to be negligible below 100 Hz in a nonaggressive environment.

NOTE 4—Certain crack shapes are more readily produced in axial tension, others in bending (see [Annex A1](#)).

5.2.1 Devices and fixtures for cantilever bending of sheet and plate specimens are described in Refs. (2) and (3), respectively. Others may be equally suitable. The axial fatigue machines described in Practice E466 are suitable for precracking in tension; however, since the precracking operation is terminated prior to specimen failure, one should ensure that load variations during slowdown or shutdown do not exceed those desired.

5.2.2 A magnifier of about 20 power should be used to monitor the fatigue precracking process. Ease of observation will be enhanced if the cyclic rate can be reduced to about 1 Hz when desired. Alternatively, a stroboscopic light synchronized with the maximum application of tensile force may serve as well.

5.3 *Testing Machine*—The test should be conducted with a tension testing machine that conforms to the requirements of Practices E4.

5.3.1 The devices for transmitting force to the specimen shall be such that the major axis of the specimen coincides with the load axis. The pin-and-clevis arrangement described in Test Method E338 should be suitable for specimens whose width is less than about 4 in. [100 mm]. An arrangement such as that shown in Fig. 2 of Practice E561 should be suitable for wider specimens.

5.3.2 For tests at other than room temperature, the temperature control and temperature measurement requirements of Test Method E338 are appropriate.

5.4 *Displacement Gage (Optional)*—If used to measure CMOD, the displacement gage output should accurately indicate the relative displacement of two gage points on the cracked surface, spanning the crack at the midpoint of its length. Further information on displacement gages appears in [Appendix X2](#).

5.5 For some combinations of material and crack geometry, the crack may propagate entirely through the thickness prior to total failure. Methods of detecting this occurrence, should it be of interest, are discussed briefly in Ref. (1).

6. Test Specimen

6.1 *Configuration and Notation*—The SCT test specimen and the notation used herein are shown in Fig. 1. Grip details have been omitted, since grip design may depend on specimen size (5.3.1) and material toughness. In general, the only

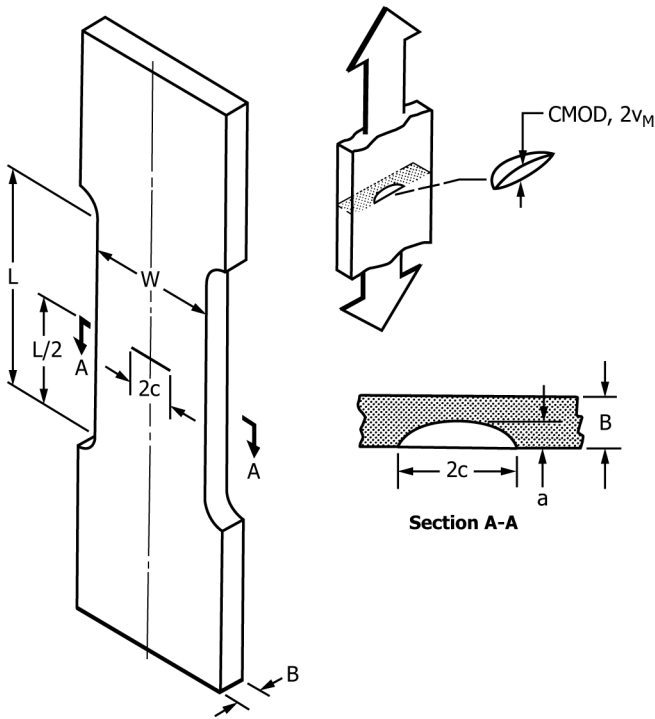

FIG. 1 Typical Surface-Crack Specimen (Grip Details Omitted) and Nomenclature

vice dimensions should be used but one should not then attempt to generalize data from such tests.

6.3 *Fatigue Precracking*—The object is to produce at a prescribed location a fatigue crack whose configuration is regular (that is, a half-ellipse or a segment of a circle), whose depth and length are close to predetermined target values, and whose subsequent fracture behavior will not be influenced by any detail of the preparation process. A small slit or crack starter is machined into the specimen surface at the center of the test section (Fig. 2) to locate and help initiate the fatigue crack. Regularity of crack configuration is influenced primarily by fatigue force uniformity, which can be maximized by careful alignment of force train and fixtures. Material inhomogeneity, residual stresses, and starter notch root radius variation can produce irregularities which may be beyond control. Fatigue crack size and shape control are discussed in Annex A1.

6.3.1 Crack starters have been produced by a variety of methods. The following procedures are known to produce acceptable results.

6.3.1.1 The crack starter should be machined, either by slitting with a thin jeweler’s circular saw or similar cutter or by electrical discharge machining (EDM) with a thin, shaped electrode.

6.3.1.2 The crack starter plane should be perpendicular to the specimen face and the tensile force vector within 10°.

6.3.1.3 The starter notch root radius should be less than 0.010 in. [0.25 mm].

6.3.1.4 The crack starter length and depth should be chosen with the desired crack dimensions and the requirements of 6.3.2.2 in mind.

6.3.2 The following procedures should ensure the production of an effective sharp fatigue crack.

6.3.2.1 Fatigue crack with the specimen in the heat treatment condition in which it is to be tested, if at all possible.

6.3.2.2 Whenever it is physically possible, the crack should be extended at least 0.05 in. [1.3 mm]; in any event the fatigue

gripping requirements are that the arrangement be strong enough to carry the maximum expected force and that it allow uniform distribution of force over the specimen cross section.

6.2 *Dimensions*—The crack depth and length and specimen thickness should be chosen according to the ultimate purpose of the test. Further discussion of this subject may be found in Appendix X3. The specimen width W should be at least 5 times the crack length $2c$ and the specimen test section length L should be at least twice the width W . Should these width and length dimensions exceed actual service dimensions, the ser-

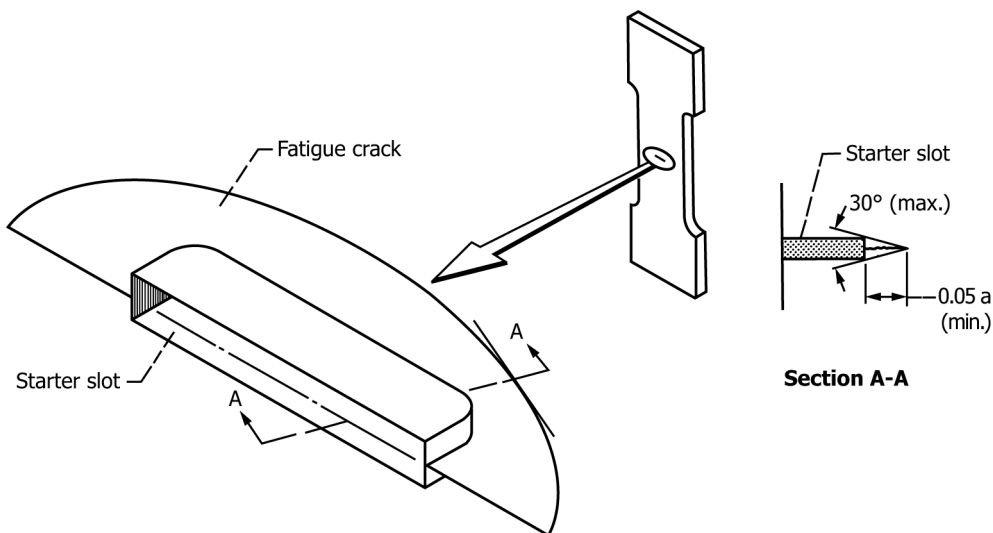

NOTE 1—Section A-A refers to the plane normal to any tangent to the crack periphery and containing the point of tangency.

FIG. 2 Fatigue Crack and Starter Details

crack extension must not be less than 5 % of the final crack depth, and the crack and its starter must lie entirely within an imaginary 30° wedge whose apex is at the crack tip. These two-dimensional descriptions shall apply around the entire crack front, that is, in all planes normal to tangents to all points on the crack periphery (Fig. 2).

6.3.2.3 The ratio of minimum to maximum cyclic stress, R , should not be greater than 0.1.

6.3.2.4 For at least the final 2.5 % of the total crack depth, the ratio K_{\max}/E should not exceed 0.002 in.^{1/2} [0.00032 m^{1/2}], where K_{\max} is the maximum stress intensity factor during fatigue cracking and E is the material's elastic modulus. An estimate of K_{\max} can be computed based on the cyclic stress and the target crack dimensions using the appropriate equation from Annex A2. Compute K_{\max} at the surface or at the deepest point, whichever is greater.

7. Procedure

7.1 *Number of Tests*—If only one crack geometry (that is, fixed crack depth and length) is to be studied, at least three specimens should be tested. If geometry is to be varied, at least two specimens should be tested for each combination of depth-to-length ($a/2c$) and depth-to-thickness (a/B) ratios.

7.2 *Specimen Measurements*—Measure the specimen thickness B at the points midway between each crack tip and the nearest specimen edge, to the nearest 0.001 in. [0.025 mm] or 0.1 %, whichever is larger. If these measurements are not within 3 % of their average, the specimen should be discarded or remachined as appropriate. Measure the specimen width W at the crack plane to within 1 % of W .

7.3 *Testing*—Conduct the test in a manner similar to that for an ordinary tension specimen. The test loading rate shall be such that the rate of increase of the nominal stress P/BW is less than 100 000 psi [690 MPa]/min. Record the maximum force, P_{\max} , reached during the test.

7.4 *Test Record*—If CMOD is measured, a test record should be made consisting of an autographic plot or digital record of the output of a force-sensing transducer versus the displacement gage output.

7.5 *Crack Measurements*—After fracture, measure the crack depth a and the crack length $2c$ to the nearest 0.001 in. [0.025

mm] or 0.1 %, whichever is larger. A low-power [20 to 50 ×] traveling microscope is usually satisfactory. Observe the crack shape; it should closely approximate a semiellipse or a segment of a circle. If the crack shape is irregular or unsymmetric the test should be discarded. Using the actual crack dimensions, verify that the requirement 6.3.2.4 was indeed met.

7.6 *Residual Strength*—Calculate the residual strength as $\sigma_r = P_{\max}/(BW)$.

8. Report

8.1 The report should include the following for each specimen tested:

8.1.1 Test section width, W , and thickness, B .

8.1.2 Maximum stress intensity factor during fatigue precracking, K_{\max} , based on actual crack dimensions.

8.1.3 Fatigue crack depth, a , and length, $2c$.

8.1.4 Maximum force observed during the test, P_{\max} , and the corresponding residual strength, σ_r .

8.2 The following should also be reported. If an item is a controlled variable, it should be reported for each specimen; if common to an identifiable block of specimens, it need be reported only once.

8.2.1 Crack starter dimensions.

8.2.2 Mode of loading during fatigue cracking and the stress ratio R .

8.2.3 Test temperature and environment.

8.2.4 Yield strength and tensile strength determined in accordance with Test Methods E8/E8M.

8.2.5 Crack plane orientation (see Test Method E399).

8.3 If available, the following should also be reported:

8.3.1 Elastic modulus, E , and Poisson's ratio, μ .

8.3.2 Forces corresponding to pop-in or breakthrough.

8.3.3 Dimensionless slope, $2E\nu_m/(1-\mu^2)\sigma a$, of the initial linear portion of the force-versus-CMOD curve, and the measurement-point gage length.

8.3.4 Number of fatigue cracking cycles from first visible cracking to final size.

9. Keywords

9.1 residual strength; surface crack; tensile force

ANNEXES

(Mandatory Information)

A1. FATIGUE CRACK SIZE AND SHAPE CONTROL

A1.1 Fatigue crack size and shape control is more of an art than a science at present. There appear to be two basic techniques.

A1.2 One approach is to vary the starter size and shape or the stress field or both to achieve the desired final configuration. In axial tension, cracks grown from simulated point