



Designation: ~~D720/D720M – 22~~ D720/D720M – 23

Standard Test Method for Free-Swelling Index of Coal¹

This standard is issued under the fixed designation D720/D720M; the number immediately following the designation indicates the year of original adoption or, in the case of revision, the year of last revision. A number in parentheses indicates the year of last reapproval. A superscript epsilon (ϵ) indicates an editorial change since the last revision or reapproval.

This standard has been approved for use by agencies of the U.S. Department of Defense.

1. Scope

1.1 This test method² is a small-scale, empirical test for obtaining information regarding the free-swelling properties of a coal. The results may be used as an indication of the caking characteristic of the coal when burned as a fuel. This test is not recommended as a method for the determination of expansion of coals in coke ovens.

1.2 *Units*—The values stated in either SI units or non-SI units are to be regarded separately as standard. The values stated in each system are not necessarily exact equivalents; therefore, to ensure conformance with the standard, each system shall be used independently of the other, and values from the two systems shall not be combined.

1.3 *This standard does not purport to address all of the safety concerns, if any, associated with its use. It is the responsibility of the user of this standard to establish appropriate safety, health, and environmental practices and determine the applicability of regulatory limitations prior to use.*

1.4 *This international standard was developed in accordance with internationally recognized principles on standardization established in the Decision on Principles for the Development of International Standards, Guides and Recommendations issued by the World Trade Organization Technical Barriers to Trade (TBT) Committee.*

2. Referenced Documents

2.1 ASTM Standards:³

[D2013/D2013M Practice for Preparing Coal Samples for Analysis](#)

[E691 Practice for Conducting an Interlaboratory Study to Determine the Precision of a Test Method](#)

3. Significance and Use

3.1 This test method, in addition to indicating the caking properties of a coal when burned as a fuel, can be used to give a broad indication of the degree of oxidation of a coal.

¹ This test method is under the jurisdiction of ASTM Committee D05 on Coal and Coke and is the direct responsibility of Subcommittee D05.15 on Metallurgical Properties of Coal and Coke.

Current edition approved Sept. 1, 2022/Nov. 1, 2023. Published October 2022/December 2023. Originally approved in 1943. Last previous edition approved in 2015/2022 as ~~D720/D720M – 15~~D720/D720M – 22.^{ε1} DOI: ~~10.1520/D0720_D0720M-22~~10.1520/D0720_D0720M-23.

² This test method is an adaptation of the Crucible Swelling Test for Coal of the British Standards Institution. For information concerning the experimental work on which this adaptation is based, see paper by Ostborg, H. N., Limbacker, H. R., and Sherman, R. A., “An Experimental Investigation of the British Standard Method for the Crucible Swelling Test for Coal,” *Proceedings*, Am. Soc. Testing Mats., Vol 42, 1042, p. 851. See also a paper by Selvig, W. A., and Ode, W. H., “An Investigation of a Laboratory Test for Determination of the Free-Swelling Index of Coal,” *U.S. Bureau of Mines Report of Investigation* 4238, Revision of R. I. 3989, 1948.

³ For referenced ASTM standards, visit the ASTM website, www.astm.org, or contact ASTM Customer Service at service@astm.org. For *Annual Book of ASTM Standards* volume information, refer to the standard’s Document Summary page on the ASTM website.

4. Apparatus

4.1 This test method can be performed using either electric or gas heating. When using electric heating, the results obtained must be the same as those obtained when using the gas heating method. The apparatus common to both electric and gas methods shall consist of the following:

4.1.1 *Crucible*, translucent silica, low-form, with a flat, close-fitting silica ring-handle lid and an extra pierced lid for use in determining the crucible temperature, conforming to the following requirements:

Mass, g	11.0 to 12.75
External height, mm	26 ± 0.5
External diameter at top, mm	41 ± 0.75
Internal diameter at base, min, mm	11
Capacity (approximate), cm ³	17

4.1.2 *Sight Tube*, as shown in Fig. 1, for viewing the coke buttons so that the effect of parallax will be eliminated. Make the tube of any rigid and preferably opaque material and support vertically on a ring stand. The sight tube shall be 38 mm [1.5 in.] in diameter and 250 mm [10 in.] in length and supported on the ring stand at a height of 76 mm [3.0 in.] above the base of the stand.

4.1.3 *Thermocouple and Potentiometer*—External, employed for calibration of the electric furnace and Potentiometer-gas burner assembly.

4.1.4 *Mass*, 500 g ± 10 g, having a flat bottom surface. Employed to assign the index of a non-swollen button.

4.2 The electric apparatus shall consist of the following:

4.2.1 *Furnace*, consisting of a refractory base, a heating element, crucible shelf, and a refractory chimney. The furnace shall be capable of having the temperature regulated at 800 °C ± 10 °C [1472 °F ± 18 °F] and 820 °C ± 5 °C [1508 °F ± 9 °F] as measured by a thermocouple positioned in the crucible. An example design is shown in Fig. 2.

4.2.2 *Crucible Support*—A convenient crucible support consists of a cradle support made from nickel-chromium wire suspended from a metal ring. The height of the support inside the furnace shall be adjustable.

4.2.3 *Thermocouple*—(Optional) Suitable sheathed thermocouple with its exposed thermojunction positioned in the zone of uniform temperature, temperature of the furnace, as is shown in Fig. 2, employed to monitor the temperature of the furnace.

4.2.4 *Electric Controls*—Suitable manual or automatic transformer capable of maintaining the furnace temperature at 800 °C ± 10 °C [1472 °F ± 18 °F] after 1.5 min and 820 °C [1508 °F] ± 5 °C [1508 °F ± 9 °F] after 2.5 min.

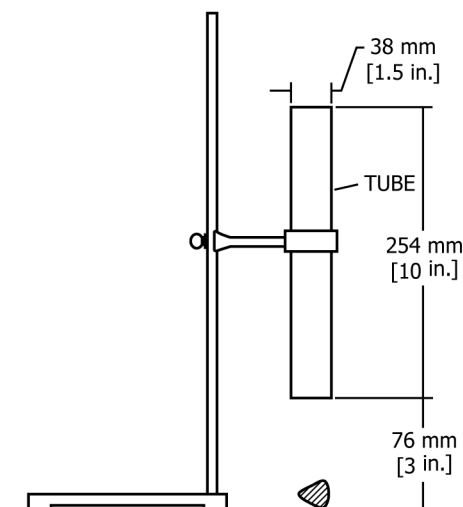

FIG. 1 Sight Tube

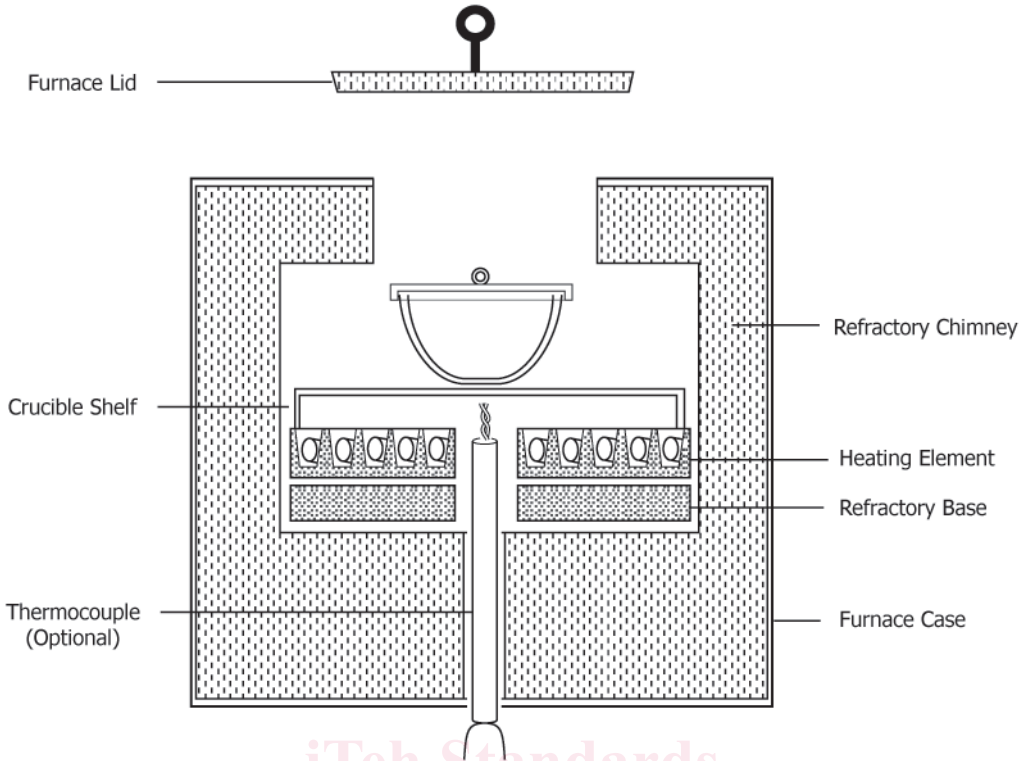

FIG. 2 Example Furnace Base and Chimney

iTeh Standards
<https://standards.itih.ai>
 Document Preview

4.3 The gas apparatus shall consist of the following:

4.3.1 *Burner*—Gas burner capable of obtaining the required temperature of $820\text{ }^{\circ}\text{C}$ [$1500\text{ }^{\circ}\text{F}$], $\pm 5\text{ }^{\circ}\text{C}$ [$1508\text{ }^{\circ}\text{F} \pm 9\text{ }^{\circ}\text{F}$]. A Meker-Type Bunsen burner or Teclu-Type burner has been found to be sufficient. The burner shall have a grid of external diameter, 30.0 mm to 42.0 mm [1.18 in. to 1.65 in.]. The burner may use any combination natural gas or liquid petroleum gas and oxidant in order to obtain the required temperature. See Fig. 3.

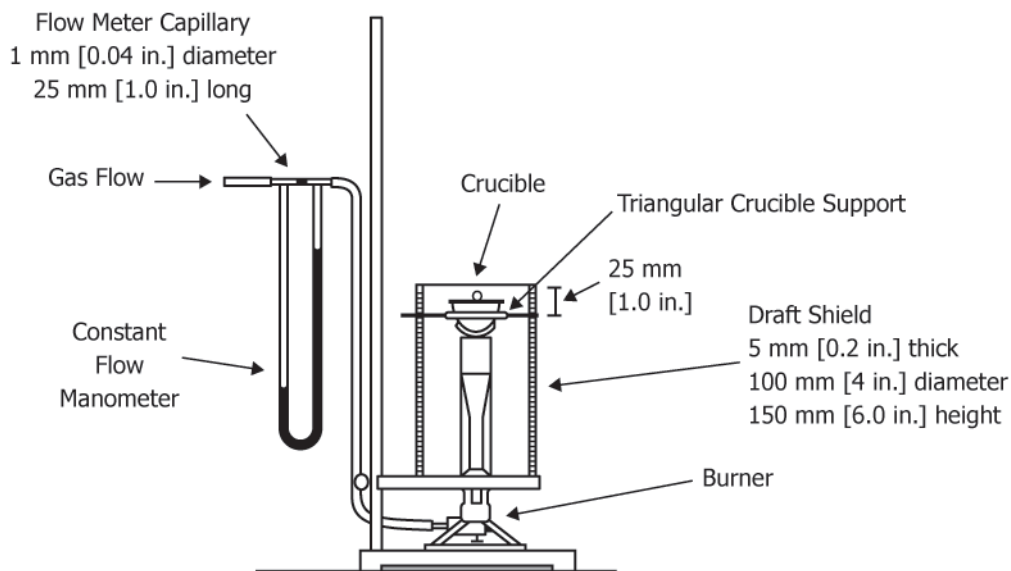

FIG. 3 Example of Burner Assembly

4.3.2 *Draft Shield*, constructed from 5 mm [0.2 in.] thick refractory pipe, having an internal diameter of 100 mm [4 in.] and a length of 150 mm [6 in.]. The top shall have three slots, 25 mm [1.0 in.] in depth, in which the wires of the crucible support rest. Support the draft shield on a ring stand, so that the distance between the base of the crucible and the top of the burner grid may be adjusted by raising or lowering the draft shield. See Fig. 3.

4.3.3 *Triangular Crucible Support*, constructed from three pieces of translucent silica tubing each approximately 63 mm [2.5 in.] in length, approximately ~~6.0 mm to 6.5 mm~~ 6 mm to 7 mm [0.2 in. to 0.3 in.] in external diameter, and mounted on chromium-nickel wire so that the diameter of the inscribed circle is approximately 32 mm [1.3 in.] as shown in Fig. 4. The twisted ends of the triangle may be joined together by a loop of wire to facilitate removal of the hot crucible.

4.3.4 *Flowmeter*—Suitable gauge for measuring the gas flow, such as a variable area flowmeter or a capillary flowmeter with water manometer placed in the gas line before the burner as a guide to the control of the rate of gas flow (Fig. 3).

5. Calibration

5.1 Electric Furnace:

5.1.1 Turn the main power switch on and adjust the variable transformer so that the furnace will obtain a temperature of $820\text{ }^{\circ}\text{C} \pm 5\text{ }^{\circ}\text{C}$ [$1508\text{ }^{\circ}\text{F} \pm 9\text{ }^{\circ}\text{F}$]. Allow the furnace temperature to reach equilibrium.

5.1.2 Lower an empty crucible with pierced lid into the furnace using the crucible support. Measure the temperature at the inside base of the crucible with a thermocouple and a potentiometer. The unprotected junction of the thermocouple must be in contact with the inside base of the crucible. At the end of 1.5 min, the furnace ~~should~~ shall obtain a temperature of $800\text{ }^{\circ}\text{C} \pm 10\text{ }^{\circ}\text{C}$ [$1472\text{ }^{\circ}\text{F} \pm 18\text{ }^{\circ}\text{F}$], and at the end of 2.5 min, $820\text{ }^{\circ}\text{C} \pm 5\text{ }^{\circ}\text{C}$ [$1508\text{ }^{\circ}\text{F} \pm 9\text{ }^{\circ}\text{F}$]. Adjust the variable transformer as necessary to achieve the required temperatures.

5.2 Gas Burner:

5.2.1 With the burner assembly arranged as shown in Fig. 3, and with an empty crucible in position, light the burner approximately 15 min before making a determination to allow the draft shield to rise to an equilibrium temperature.

5.2.2 After placing a crucible in position, adjust the flow of gas and the relative positions of the burner and the draft shield so that the temperature of the inner surface of the bottom of the crucible reaches $800\text{ }^{\circ}\text{C} \pm 10\text{ }^{\circ}\text{C}$ [$1472\text{ }^{\circ}\text{F} \pm 18\text{ }^{\circ}\text{F}$] in 1.5 min and $820\text{ }^{\circ}\text{C} \pm 5\text{ }^{\circ}\text{C}$ [$1508\text{ }^{\circ}\text{F} \pm 9\text{ }^{\circ}\text{F}$] in 2.5 min. These desired temperatures may usually be obtained by setting the draft shield so that the bottom of the crucible is approximately 10 mm [0.4 in.] above the burner grid, and then adjusting the gas flame. Determine the crucible temperature by means of a thermocouple and a potentiometer. Insert the thermocouple through the pierced crucible lid so that the unprotected junction of the thermocouple is in contact with the base of the crucible.

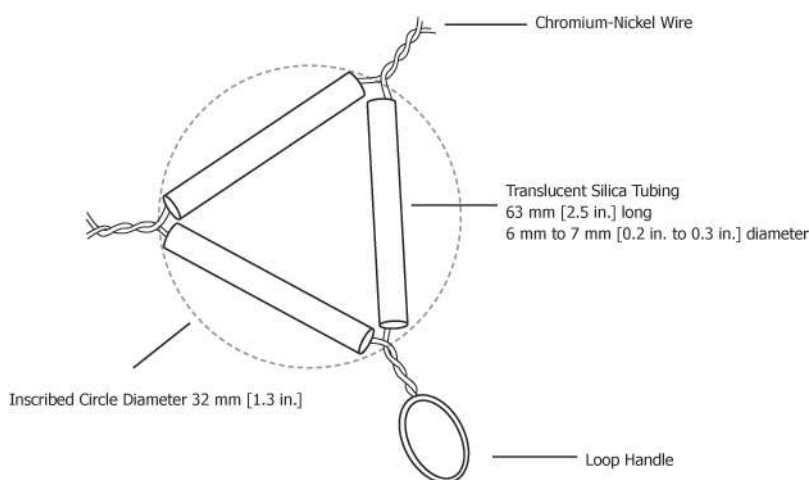

FIG. 4 Triangular Crucible Support