



Designation: **D4486 – 18** **D4486 – 23**

Standard Test Method for Kinematic Viscosity of Volatile and Reactive Liquids¹

This standard is issued under the fixed designation D4486; the number immediately following the designation indicates the year of original adoption or, in the case of revision, the year of last revision. A number in parentheses indicates the year of last reapproval. A superscript epsilon (ϵ) indicates an editorial change since the last revision or reapproval.

1. Scope*

1.1 This test method covers the measurement of kinematic viscosity of transparent, Newtonian liquids which because of their reactivity, instability, or volatility cannot be used in conventional capillary kinematic viscometers. This test method is applicable up to 2×10^{-5} N/m² (2 atm) pressure and temperature range from -53 °C to $+135$ °C (-65 °F to $+275$ °F).

1.1.1 For the measurement of the kinematic viscosity of other liquids, see Test Method **D445**. The difference between the two methods is in the viscometers. The viscometers specified in used Specification **D446** are open to the atmosphere, while the viscometers in this method are sealed. When volatile liquids are measured in sealed viscometers, the density of the vapor may not be negligible compared with the density of the liquid and the working equation of the viscometer has to account for that. See Section **11** for details.

1.2 **WARNING**—Mercury has been designated by many regulatory agencies as a hazardous substance that can cause serious medical issues. Mercury, or its vapor, has been demonstrated to be hazardous to health and corrosive to materials. Use Caution when handling mercury and mercury-containing products. See the applicable product Safety Data Sheet (SDS) for additional information. The potential exists that selling mercury or mercury-containing products, or both, is prohibited by local or national law. Users must determine legality of sales in their location.

1.3 *This standard does not purport to address all of the safety concerns, if any, associated with its use. It is the responsibility of the user of this standard to establish appropriate safety, health, and environmental practices and determine the applicability of regulatory limitations prior to use.* For specific warning statements, see **7.2**, **7.3**, **7.4**, and **Annex A1**.

1.4 *This international standard was developed in accordance with internationally recognized principles on standardization established in the Decision on Principles for the Development of International Standards, Guides and Recommendations issued by the World Trade Organization Technical Barriers to Trade (TBT) Committee.*

2. Referenced Documents

2.1 ASTM Standards:²

[D445 Test Method for Kinematic Viscosity of Transparent and Opaque Liquids \(and Calculation of Dynamic Viscosity\)](#)

[D446 Specifications and Operating Instructions for Glass Capillary Kinematic Viscometers](#)

[D2162 Practice for Basic Calibration of Master Viscometers and Viscosity Oil Standards](#)

[D4175 Terminology Relating to Petroleum Products, Liquid Fuels, and Lubricants](#)

[E1 Specification for ASTM Liquid-in-Glass Thermometers](#)

[SI 10 IEEE/ASTM Standard for Use of the International System of Units \(SI\): The Modern Metric System](#)

¹ This test method is under the jurisdiction of Committee **D02** on Petroleum Products, Liquid Fuels, and Lubricants and is the direct responsibility of Subcommittee **D02.L0.07** on Engineering Sciences of High Performance Fluids and Solids (Formally D02.1100).

Current edition approved Dec. 1, 2018; Dec. 1, 2023. Published February 2019; December 2023. Originally approved in 1991. Last previous edition approved in 2010 as **D4486 – 10**; **D4486 – 18**. DOI: [10.1520/D4486-18](https://doi.org/10.1520/D4486-18); [10.1520/D4486-23](https://doi.org/10.1520/D4486-23).

² For referenced ASTM standards, visit the ASTM website, www.astm.org, or contact ASTM Customer Service at service@astm.org. For *Annual Book of ASTM Standards* volume information, refer to the standard's Document Summary page on the ASTM website.

*A Summary of Changes section appears at the end of this standard

3. Terminology

3.1 Definitions:

3.1.1 For definitions of terms used in this test method, refer to Terminology [D4175](#).

3.2 Definitions of Terms Specific to This Standard:

3.2.1 ~~density~~—*density, n* —the mass per unit volume of a substance at a given temperature and pressure.

3.2.1.1 Discussion—

The cgs unit of density (ρ) has the dimensions of grams per cubic centimetre. The SI unit of density has the dimensions of kilograms per cubic metre.

3.2.2 *dynamic viscosity, η , n* —the ratio between the applied shear stress and rate of shear of a material.

3.2.2.1 Discussion—

—It is sometimes called the coefficient of dynamic viscosity or absolute viscosity. Dynamic viscosity is a measure of resistance to flow or deformation which constitutes a material's ability to transfer momentum in response to steady or time-dependent external shear forces. Dynamic viscosity has the dimension of mass divided by length and time and its SI unit is pascal times second (Pa·s). Among the transport properties for heat, mass, and momentum transfer, dynamic viscosity is the momentum conductivity.

3.2.3 *kinematic viscosity, ν , n* —the ratio of the dynamic viscosity (η) to the density (ρ) of a material at the same temperature and pressure.

3.2.3.1 Discussion—

—~~Kinematic~~**Kinematic** viscosity is the ratio between momentum transport and momentum storage. Such ratios are called diffusivities with dimensions of length squared divided by time and the SI unit is metre squared divided by second (m^2/s). Among the transport properties for heat, mass, and momentum transfer, kinematic viscosity is the momentum diffusivity.

3.2.3.2 Discussion—

Formerly, kinematic viscosity was defined specifically for viscometers covered by this test method as the resistance to flow under gravity. More generally, it is the ratio between momentum transport and momentum storage.

3.2.3.3 Discussion—

—~~For~~**For** gravity-driven flow under a given hydrostatic head, the pressure head of a liquid is proportional to its density, ρ , if the density of the gas or vapor is negligible compared to that of the liquid. For any particular viscometer covered by this test method, the time of flow of a fixed volume of liquid is directly proportional to its kinematic viscosity, ν , where $\nu = \eta/\rho$, and η is the dynamic viscosity.

3.2.3.4 Discussion—

If the density of the gas or vapor is not negligible compared to that of the liquid, it has to be taken into account in the calculation of the viscosity. Details are given in Section 11.

3.2.4 ~~vulnerable liquid~~—*liquid, n* —a liquid which by reason of its volatility, instability or reactivity in the presence of air or any other specific gaseous medium may undergo physical or chemical changes that may affect its viscosity.

4. Summary of Test Method

4.1 The time is measured, in seconds, for a fixed volume of liquid to flow under gravity through the capillary of the viscometer under a reproducible driving head and at a closely controlled temperature. The kinematic viscosity is calculated from the measured flow time and the calibration constant of the viscometer.

5. Significance and Use

5.1 Kinematic viscosity is a physical property which is of importance in the design of systems in which flowing liquids are used or handled.

6. Apparatus

6.1 *Viscometer*—A viscometer suitable for vulnerable fluids similar to that shown in [Fig. 1](#).

6.2 *Viscometer Thermostat*—Any transparent liquid or vapor bath of sufficient depth such that at no time during the measurement will any portion of the sample in the viscometer be less than 20 mm below the surface of the bath liquid or less than 20 mm above

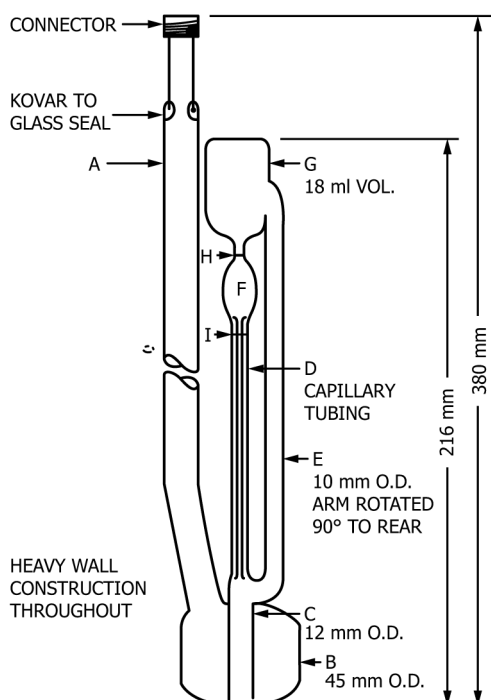

Variants of sealed gravitational capillary viscometers have been used some of them sustaining pressures up to 3 MPa. A survey is given in the book section “Sealed Gravitational Capillary Viscometers for Volatile Liquids” by A. Laesecke in “Experimental Thermodynamics Volume IX : Advances in Transport Properties of Fluids” edited by M. J. Assael, A. R. H. Goodwin, V. Vesovic, & W. A. Wakeham, Cambridge, UK: Royal Society of Chemistry, 2014, <http://dx.doi.org/10.1039/9781782625254>.

FIG. 1 Viscometer for Vulnerable Liquids

(<https://standards.iteh.ai>)

Document Preview

the bottom of the bath may be used. The temperature control must be such that for the range from 15 °C to 100 °C (60 °F to 212 °F) the temperature of the bath medium does not vary by more than 0.02 °F (0.01 °C) over the length of the viscometers, or between the position of each viscometer, or at the location of the thermometer. For temperatures outside this range, the variation must not exceed 0.05 °F (0.03 °C).

ASTM D4486-23

<https://standards.iteh.ai/catalog/standards/astm/ee72d577-29a6-4d6f-bb73-b477ba24a37b/astm-d4486-23>

6.3 *Temperature Measuring Device*—A resistance thermometer (RTD) capable of measurement to ± 0.01 °C (0.02 °F) is the preferred device for temperature measurement. The use of suitable liquid-in-glass Kinematic Viscosity Test Thermometers covering the range of test temperatures indicated in Table 1 as listed in Specification E1, is permitted provided they have been standardized before use (see 8.2). The use of an RTD is preferred because the thermometers listed in Specification E1 contain mercury. See Test Method D445 for additional information on the use and selection of temperature measuring devices.

6.4 *Timing Device*—Any timing device may be used provided that the readings can be taken with a discrimination of 0.2 s or smaller, and that it has an uncertainty within ± 0.07 % when tested over intervals of 15 min.

6.4.1 Electrical timing devices may be used if the current frequency is controlled to an uncertainty of 0.05 % or less. Alternating currents, as provided by some public power systems, are intermittently rather than continuously controlled. When used to actuate electrical timing devices, such control can cause large errors in viscosity flow measurements.

7. Reagents and Materials

7.1 *Viscosity Oil Standards*, conforming to ASTM viscosity oil standards having the approximate kinematic viscosity shown in Table 1. Certified kinematic viscosity values are compared by annual cooperative tests by a number of laboratories and are supplied with each portion.

7.2 *Chromic Acid (Cleaning Solution)*—(Warning—Causes severe burns. A recognized carcinogen. Strong oxidizer, contact with organic material may cause fire. Hygroscopic. See A1.2.)

TABLE 1 Approximate Values of the ASTM Viscosity Standards

Viscosity Standard Conforming to ASTM Standards ^A	Approximate Kinematic Viscosity, cSt=1 mm ² ·s ⁻¹ =10 ⁻⁶ m ² ·s ⁻¹								
	At -53.89 °C (-65 °F)	At - 40 °C (-40 °F)	At 20 °C (68 °F)	At 25 °C (77 °F)	At ^B 37.78 °C (100 °F)	At 40 °C (104 °F)	At 50 °C (122 °F)	At ^B 98.89 °C (210 °F)	At 100 °C (212 °F)
S-3	300	80	4.6	4.0	3.0	2.9	...	1.2	1.2
S-6	11	8.9	6.0	5.7	...	1.8	1.8
S-20	44	34	20	18	...	4.0	3.9
S-60	170	120	60	54	...	7.4	7.2
S-200	640	450	200	180	...	17	17
S-600	2400	1600	600	520	280	33	32
S-2000	8700	5600	2000	1700	...	78	75
S-8000	37 000	23 000	8000	6700
S-30000	81 000	27 000	23 000	11 000

^A The actual values for the standards listed above are established and annually reaffirmed by cooperative tests. In 1971, tests were made using 15 different types of viscometers in 26 laboratories located in 9 countries.

^B Standardizations at 37.78 °C and 98.89 °C are to be discontinued Jan 1, 1977.

7.2.1 Other suitable cleaning solutions³ are available. In referee testing situations, glassware shall be cleaned with a cleaning solution agreed upon by the parties involved.

7.3 *Acetone*—(**Warning**—Extremely flammable. Vapors may cause flash fire. See Annex A1.3.)

7.4 *Hydrochloric Acid (Concentrated)*—(**Warning**—Poison. Corrosive. May be fatal if swallowed. Liquid and vapor cause severe burns. Harmful if inhaled. See Annex A1.4.)

8. Standardization

8.1 *Viscometers*—Only calibrated viscometers standardized as described in Annex A2 shall be used.

8.2 *Temperature*—Temperature measuring devices shall be checked to the nearest 0.01 °C (0.02 °F) by comparison to a suitable standardized instrument. Liquid-in-glass thermometers shall be standardized at “total immersion,” which means immersion to the top of the liquid column with the remainder of the stem and the expansion chamber at the top of the thermometer exposed to room temperature; do not submerge the expansion bulb at the top of the thermometer. It is essential that the ice point of the standardized thermometers be determined periodically and the official corrections be adjusted to reflect the change in the ice point.

8.3 *Timers*—Standard time signals available in some nations may be used in checking the uncertainty of timing devices. In the United States of America, time signals, as broadcast by the National Institute of Standards and Technology, Station WWV, Fort Collins, CO and Station WWVH Kauai, HI at 2.5 MHz, 5 MHz, 10 MHz, 15 MHz, and 20 MHz are a convenient and primary standard reference for calibrating timing devices; the signals are broadcast 24 h daily. Station CHU from Ottawa, Canada, at 3.330 MHz, 7.335 MHz, and 14.670 MHz or Station MSF at Rugby, United Kingdom, at 2.5 MHz, 5 MHz, and 10 MHz may be received better in some locations.

8.4 Viscosity standards may also be used to check the over-all kinematic viscosity procedure in a laboratory. If the measured kinematic viscosity does not agree within ±0.35 % of the certified value, each step in the procedure should be rechecked, including thermometer and viscometer calibration to locate source of error.

9. Cleaning of Viscometer

9.1 Between successive determinations, clean the viscometer thoroughly by several rinsings with an appropriate solvent completely miscible with the sample, followed by a completely volatile solvent. Dry the viscometer with vacuum attached to Tube A or by placing viscometer in a vacuum oven.

³ Other suitable chromium free, sulfuric acid-based cleaning solutions are available.