



Designation: D2879 – 23

Standard Test Method for Vapor Pressure-Temperature Relationship and Initial Decomposition Temperature of Liquids by Isoteniscope¹

This standard is issued under the fixed designation D2879; the number immediately following the designation indicates the year of original adoption or, in the case of revision, the year of last revision. A number in parentheses indicates the year of last reapproval. A superscript epsilon (ϵ) indicates an editorial change since the last revision or reapproval.

This standard has been approved for use by agencies of the U.S. Department of Defense.

1. Scope*

1.1 This test method covers the determination of the vapor pressure of pure liquids, the vapor pressure exerted by mixtures in a closed vessel at $40\% \pm 5\%$ ullage, and the initial thermal decomposition temperature of pure and mixed liquids. It is applicable to liquids that are compatible with borosilicate glass and that have a vapor pressure between 133 Pa (1.0 torr) and 101.3 kPa (760 torr) at the selected test temperatures. The test method is suitable for use over the range from ambient to 623 K. The temperature range may be extended to include temperatures below ambient provided a suitable constant-temperature bath for such temperatures is used.

NOTE 1—The isoteniscope is a constant-volume apparatus and results obtained with it on other than pure liquids differ from those obtained in a constant-pressure distillation.

1.2 Most petroleum products boil over a fairly wide temperature range, and this fact shall be recognized in discussion of their vapor pressures. Even an ideal mixture following Raoult's law will show a progressive decrease in vapor pressure as the lighter component is removed, and this is vastly accentuated in complex mixtures such as lubricating oils containing traces of dewaxing solvents, etc. Such a mixture may well exert a pressure in a closed vessel of as much as 100 times that calculated from its average composition, and it is the closed vessel which is simulated by the isoteniscope. For measurement of the apparent vapor pressure in open systems, Test Method D2878, is recommended.

1.3 The values stated in SI units are to be regarded as standard. The values given in parentheses after SI units are provided for information only and are not considered standard.

1.4 **WARNING**—Mercury has been designated by many regulatory agencies as a hazardous substance that can cause serious medical issues. Mercury, or its vapor, has been dem-

¹ This test method is under the jurisdiction of ASTM Committee D02 on Petroleum Products, Liquid Fuels, and Lubricants and is the direct responsibility of Subcommittee D02.L0.07 on Engineering Sciences of High Performance Fluids and Solids (Formally D02.1100).

Current edition approved Dec. 1, 2023. Published December 2023. Originally approved in 1970. Last previous edition approved in 2018 as D2879 – 18. DOI: 10.1520/D2879-23.

onstrated to be hazardous to health and corrosive to materials. Use caution when handling mercury and mercury-containing products. See the applicable product Safety Data Sheet (SDS) for additional information. The potential exists that selling mercury or mercury-containing products, or both, is prohibited by local or national law. Users must determine legality of sales in their location.

1.5 *This standard does not purport to address all of the safety concerns, if any, associated with its use. It is the responsibility of the user of this standard to establish appropriate safety, health, and environmental practices and determine the applicability of regulatory limitations prior to use. For specific warning statements, see 6.10, 6.12, and Annex A2.*

1.6 *This international standard was developed in accordance with internationally recognized principles on standardization established in the Decision on Principles for the Development of International Standards, Guides and Recommendations issued by the World Trade Organization Technical Barriers to Trade (TBT) Committee.*

2. Referenced Documents

2.1 *ASTM Standards:*²

- D2878 Test Method for Estimating Apparent Vapor Pressures and Molecular Weights of Lubricating Oils
- D4175 Terminology Relating to Petroleum Products, Liquid Fuels, and Lubricants
- E230 Specification for Temperature-Electromotive Force (emf) Tables for Standardized Thermocouples

3. Terminology

3.1 *Definitions:*

3.1.1 For definitions of terms used in this test method, refer to Terminology D4175.

3.2 *Definitions of Terms Specific to This Standard:*

3.2.1 *ullage, n*—that percentage of a closed system which is filled with vapor.

² For referenced ASTM standards, visit the ASTM website, www.astm.org, or contact ASTM Customer Service at service@astm.org. For *Annual Book of ASTM Standards* volume information, refer to the standard's Document Summary page on the ASTM website.

*A Summary of Changes section appears at the end of this standard

3.2.1.1 *Discussion*—Specifically, on Fig. 1, that portion of the volume of the isoteniscope to the right of point A that is filled with vapor.

3.3 *Symbols:*

- C = temperature, °C,
- K = temperature, K,
- p = pressure, Pa or torr,
- P_c = experimentally measured total system pressure,
- P_a = partial pressure due to fixed gases dissolved in sample,
- P_c = corrected vapor pressure, Pa or torr.
- t = time, s,

$$K = C + 273.15 \quad (1)$$

4. Summary of Test Method

4.1 Dissolved and entrained fixed gases are removed from the sample in the isoteniscope by heating a thin layer of a sample at reduced pressure, removing in this process the minimum amount of volatile constituents from the sample.

4.2 The vapor pressure of the sample at selected temperatures is determined by balancing the pressure due to the vapor of the sample against a known pressure of an inert gas. The manometer section of the isoteniscope is used to determine pressure equality.

4.3 The initial decomposition temperature is determined from a plot of the logarithm of the vapor pressure versus the reciprocal of absolute temperature. The initial decomposition temperature is taken as that temperature at which the plot first departs from linearity as a result of the decomposition of the sample. An optional method provides for the use of isothermal rates of pressure rise for this purpose (see Annex A1). These are measured at several temperatures and the logarithm of the rate of pressure rise is plotted versus the reciprocal of absolute temperature. The decomposition temperature of the sample is taken to be that temperature at which the rate of increase of pressure is sufficient to produce a rise of 185 Pa (0.0139 torr/s).

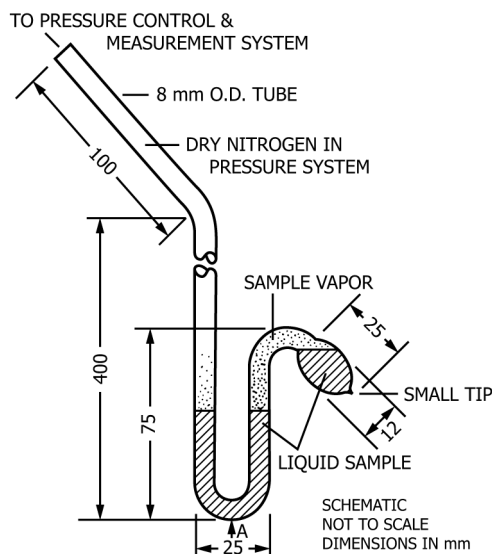

FIG. 1 Isoteniscope

NOTE 2—Vapor pressures less than 133 Pa (1.0 torr), but greater than 13.3 Pa (0.1 torr) at a selected test temperature can be determined directly with reduced accuracy. In some cases the tendency of the sample to retain dissolved or occluded air may prevent direct determinations of vapor pressure in this range. In such cases, data points obtained at higher pressures can be extrapolated to yield approximate vapor pressures in this range.

5. Significance and Use

5.1 The vapor pressure of a substance as determined by isoteniscope reflects a property of the sample as received including most volatile components, but excluding dissolved fixed gases such as air. Vapor pressure, *per se*, is a thermodynamic property which is dependent only upon composition and temperature for stable systems. The isoteniscope method is designed to minimize composition changes which may occur during the course of measurement.

6. Apparatus

6.1 *Isoteniscope* (Fig. 1).

6.2 *Constant-Temperature Air Bath*—(Fig. 2) for use over the temperature range from ambient to 623 K, controlled to ±2 K in the zone occupied by the isoteniscope beyond point “A” (Fig. 1).

6.3 *Temperature Controller*.

6.4 *Vacuum and Gas Handling System* (Fig. 3).

6.5 *Pressure Measurement Instrumentation*—Pressure transducers of suitable ranges are the preferred means for the measurement of pressure in the gas handling system. Alternatively bourdon-type vacuum gauges or liquid manometers may be used. Note that more than one gauge or transducer may be required for use over the range of 2.00 kPa (15 torr) to 101 kPa (760 torr) for pressures.

6.6 *McLeod Vacuum Gauge*—0 kPa to 2.00 kPa (0 torr to 15 torr), vertical primary standard type.

6.7 *Mechanical Two-Stage Vacuum Pump*.

6.8 *Direct Temperature Readout*, either potentiometric or electronic.

6.9 *Thermocouple*—in accordance with American National Standard for Temperature Measurement Thermocouples (ANSI C96.1) from Specification and Temperature Electromotive Force Tables E230.

6.10 *Nitrogen*—pre-purified grade. (**Warning**—Compressed gas under high pressure. Gas reduces oxygen available for breathing. See A2.1.)

6.11 *Nitrogen Pressure Regulator*—single-stage, 0 kPa to 345 kPa gauge (0 psig to 50 psig).

6.12 *Alcohol Lamp*—(**Warning**—Flammable. Denatured alcohol cannot be made nontoxic. See A2.2.)

7. Hazards

7.1 The apparatus includes a vacuum system and a Dewar flask (constant temperature air bath) that is subjected to elevated temperatures. Suitable means should be employed to protect the operator from implosion of these systems. These

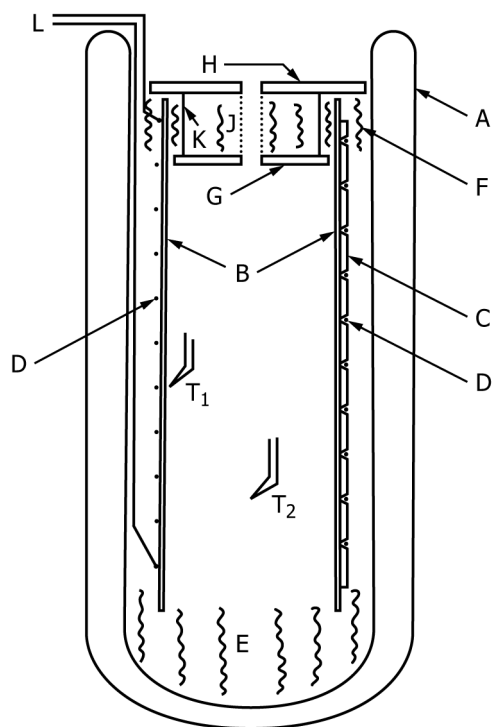

- A Dewar, strip silvered, 110 mm ID by 400 mm deep.
- B Borosilicate glass tube, 90 mm OD by 320 mm long.
- C Glass rod, 1/8 in. in diameter by 310 mm long. Three of these heater element holders are fused along their entire length to the outer surface of Tube B at 120 deg intervals. Slots cut into the fused glass rods on 3/8 in. centers serve as guides for the heating wire D.
- D Resistance wire, B. and S. No. 21 gauge, spirally wrapped around Tube B and its attached guides.
- E Glass wool pad.
- F Glass wool pad for centering Tube B and sealing annular opening.
- G Lower plate of insulated isoteniscope holder. Transite disk 1/8 in. thick, loose fit in Tube B. With hole for isoteniscope.
- H Upper plate of insulated isoteniscope holder. Transite disk 1/8 in. thick, loose fit in Dewar A. With hole for isoteniscope.
- J Glass wool insulation between plates G and H.
- K Plate spacer rods.
- L Heater leads connected to power output of temperature controller.
- T₁ Temperature-control thermocouple affixed to inside wall of Tube B.
- T₂ Temperature-indicating thermocouple affixed to isoteniscope.

FIG. 2 Constant-Temperature Air Bath

means include wrapping of vacuum vessels, use of safety shield in front of Dewar flask, and use of safety glasses by the operator.

8. Procedure

8.1 Add to the isoteniscope a quantity of sample sufficient to fill the sample bulb and the short leg of the manometer section (**Warning**—Poison. Can be harmful or fatal if inhaled or swallowed. Vapor harmful; emits toxic fumes when heated. Vapor pressure at normal room temperature exceeds threshold limit value for occupational exposure. See A1.1.) to point A of Fig. 1. Attach the isoteniscope to the vacuum system as shown in Fig. 3, and evacuate both the system and the filled isoteniscope to a pressure of 13.3 Pa (0.1 torr) as measured on the McLeod gauge. Break the vacuum with nitrogen

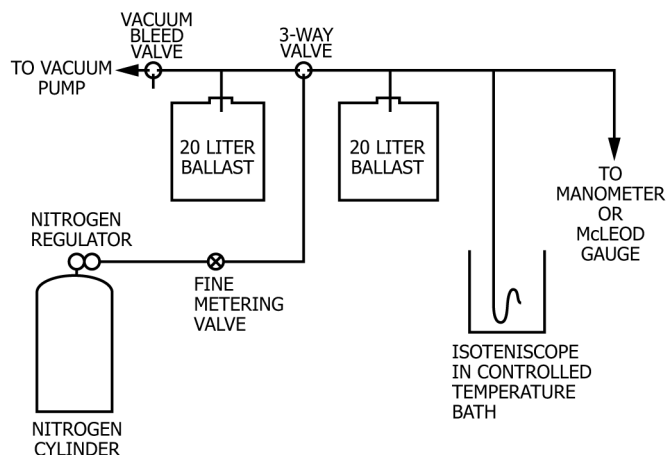

FIG. 3 Vacuum and Gas Handling System

(**Warning**—Compressed gas under high pressure. Gas reduces oxygen available for breathing. See A1.2.). Repeat the evacuation and purge of the system twice to remove residual oxygen.

8.2 Place the filled isoteniscope in a horizontal position so that the sample spreads out into a thin layer in the sample bulb and manometer section. Reduce the system pressure to 133 Pa (1 torr). Remove dissolved fixed gases by gently warming the sample with an alcohol lamp until it just boils (**Warning**—Flammable. Denatured alcohol cannot be made nontoxic. See A2.2.). Continue for 1 min.

NOTE 3—During the initial evacuation of the system, it may be necessary to cool volatile samples to prevent boiling or loss of volatiles.

NOTE 4—If the sample is a pure compound, complete removal of fixed gases may readily be accomplished by vigorous boiling at 13.3 Pa (0.1 torr). For samples that consist of mixtures of substances differing in vapor pressure, this procedure is likely to produce an error due to the loss of volatile components. Gentle boiling is to be preferred in such cases. The rate of boiling during degassing may be controlled by varying both the pressure at which the procedure is carried out and the amount of heating. In most cases, satisfactory degassing can be obtained at 133 Pa (1 torr). However, extremely viscous materials may require degassing at lower pressures. Samples of high volatility may have to be degassed at higher pressures. In the event that the vapor pressure data indicate that the degassing procedure has not completely removed all dissolved gases, it may be necessary to apply a correction to the data or to disregard data points that are so affected (see 8.7). The degassing procedure does not prevent the loss of volatile sample components completely. However, the described procedure minimizes such losses, so that for most purposes the degassed sample can be considered to be representative of the original sample less the fixed gases that have been removed.

8.3 After the sample has been degassed, close the vacuum line valve and turn the isoteniscope to return the sample to the bulb and short leg of the manometer so that both are entirely filled with the liquid. Create a vapor-filled, nitrogen-free space between the bulb and the manometer in the following manner: maintain the pressure in the isoteniscope at the same pressure used for degassing; heat the drawn-out tip of the sample bulb with a small flame until sample vapor is released from the sample; continue to heat the tip until the vapor expands sufficiently to displace part of the sample from the upper part of the bulb and manometer arm into the manometer section of the isoteniscope.