



Designation: C1331 – 18 (Reapproved 2023)

Standard Practice for Measuring Ultrasonic Velocity in Advanced Ceramics with Broadband Pulse-Echo Cross-Correlation Method¹

This standard is issued under the fixed designation C1331; the number immediately following the designation indicates the year of original adoption or, in the case of revision, the year of last revision. A number in parentheses indicates the year of last reapproval. A superscript epsilon (ϵ) indicates an editorial change since the last revision or reapproval.

1. Scope

1.1 This practice covers a procedure for measurement of ultrasonic velocity in structural engineering solids such as monolithic ceramics, toughened ceramics, and ceramic matrix composites.

1.2 This practice is based on the broadband pulse-echo contact ultrasonic method. The procedure involves a computer-implemented, frequency-domain method for precise measurement of time delays between pairs of echoes returned by the back surface of a test sample or part.

1.3 This practice describes a procedure for using a digital cross-correlation algorithm for velocity measurement. The cross-correlation function yields a time delay between any two echo waveforms (1).²

1.4 *This international standard was developed in accordance with internationally recognized principles on standardization established in the Decision on Principles for the Development of International Standards, Guides and Recommendations issued by the World Trade Organization Technical Barriers to Trade (TBT) Committee.*

2. Referenced Documents

2.1 ASTM Standards:³

- B311** Test Method for Density of Powder Metallurgy (PM) Materials Containing Less Than Two Percent Porosity
- C373** Test Methods for Determination of Water Absorption and Associated Properties by Vacuum Method for Pressed Ceramic Tiles and Glass Tiles and Boil Method for Extruded Ceramic Tiles and Non-tile Fired Ceramic Whiteware Products

¹ This practice is under the jurisdiction of ASTM Committee E07 on Nondestructive Testing and is the direct responsibility of Subcommittee E07.06 on Ultrasonic Method.

Current edition approved Dec. 1, 2023. Published December 2023. Originally approved in 1996. Last previous edition approved in 2018 as C1331 – 18. DOI: 10.1520/C1331-18R23.

² The boldface numbers in parentheses refer to the list of references at the end of this practice.

³ For referenced ASTM standards, visit the ASTM website, www.astm.org, or contact ASTM Customer Service at service@astm.org. For *Annual Book of ASTM Standards* volume information, refer to the standard's Document Summary page on the ASTM website.

E494 Practice for Measuring Ultrasonic Velocity in Materials by Comparative Pulse-Echo Method

E543 Specification for Agencies Performing Nondestructive Testing

E1316 Terminology for Nondestructive Examinations

2.2 *ASNT Documents:*⁴

Recommended Practice SNT-TC-1A for Nondestructive Testing Personnel Qualification and Certification

ANSI/ASNT CP-189 Standard for Qualification and Certification of Nondestructive Testing Personnel

2.3 *ISO Document:*

ISO 9712 Non-destructive Testing – Qualification and Certification of NDT Personnel⁵

2.4 *Aerospace Industries Association Document:*

NAS 410 Certification and Qualification of Nondestructive Testing Personnel⁶

2.5 Additional references are cited in the text and at end of this document.

3. Terminology

3.1 Definitions of Terms Specific to This Standard:

3.1.1 *back surface*—the surface of a test sample which is opposite to the front surface and from which back surface echoes are returned at normal incidence directly to the transducer.

3.1.2 *bandwidth*—the frequency range of an ultrasonic probe, defined by convention as the difference between the lower and upper frequencies at which the signal amplitude is 6 dB down from the frequency at which maximum signal amplitude occurs.

3.1.3 *broadband transducer*—an ultrasonic transducer capable of sending and receiving undistorted signals over a broad bandwidth, consisting of a thin damped piezocrystal in a buffered probe (search unit).

⁴ Available from American Society for Nondestructive Testing (ASNT), P.O. Box 28518, 1711 Arlingate Ln., Columbus, OH 43228-0518, <http://www.asnt.org>.

⁵ Available from International Organization for Standardization (ISO), ISO Central Secretariat, BIBC II, Chemin de Blandonnet 8, CP 401, 1214 Vernier, Geneva, Switzerland, <http://www.iso.org>.

⁶ Available from Aerospace Industries Association of America, Inc., 1250 Eye St. NW, Washington, DC, 20005.

3.1.4 *buffered probe*—an ultrasonic search unit as defined in Terminology E1316 but containing a delay line, or buffer rod, to which the piezocrystal is affixed within the search unit housing and which separates the piezocrystal from the test sample (Fig. 1).

3.1.5 *buffer rod*—an integral part of a buffered probe, usually a quartz or fused silica cylinder that provides a time delay between the excitation pulse from the piezocrystal and echoes returning from a sample coupled to the free end of the buffer rod.

3.1.6 *cross-correlation function*—the cross-correlation function, implemented by a digital algorithm, yields a time delay between any two (ultrasonic) echo waveforms. This time is used to determine velocity (1).

3.1.7 *dispersion*—variation of ultrasonic velocity as a function of wavelength, that is, frequency dependence of velocity.

3.1.8 *front surface*—the surface of a test sample to which the buffer rod is coupled at normal incidence (designated as test surface in Terminology E1316).

3.1.9 *group velocity*—velocity of a broadband ultrasonic pulse consisting of many different component wavelengths.

3.1.10 *test sample*—a solid coupon or material part that meets the constraints needed to make the ultrasonic velocity measurements described herein, that is, a test sample or part having flat, parallel, smooth, preferably ground or polished opposing (front and back) surfaces, and having no discrete flaws or anomalies unrepresentative of the inherent properties of the material.

3.1.11 *wavelength (λ)*—distance that sound (of a particular frequency) travels during one period (during one oscillation), $\lambda = v/f$, where v is the velocity of sound in the material and where velocity is measured in cm/ μ s, frequency in MHz, and wavelength in cm, herein.

3.2 Other terms or nomenclature used in this practice are defined in Terminology E1316.

4. Significance and Use

4.1 The velocity measurements described in this practice may be used to characterize material variations that affect

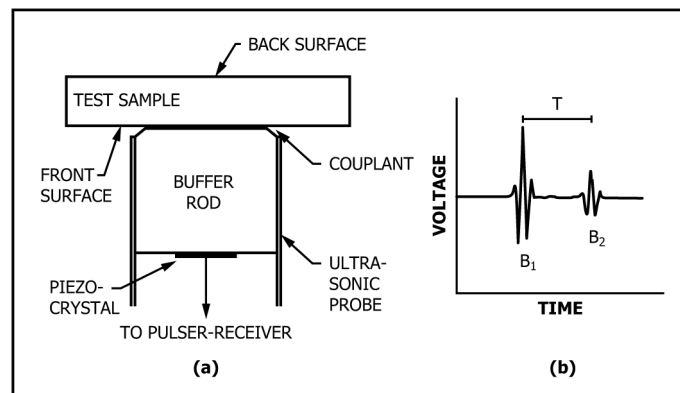

NOTE 1— B_1 and B_2 are first and second back surface echoes, respectively, and T is time interval between the echoes.

FIG. 1 Cross Section of Buffered Ultrasonic Probe (a) and Principle Echoes (b) for Velocity Measurement

mechanical or physical properties. This procedure is useful for measuring variations in microstructural features such as grain structure, pore fractions, and density variations in monolithic ceramics.

4.2 Velocity measurements described herein can assess subtle variations in porosity within a given material or component, as, for example, in ceramic superconductors and structural ceramic specimens (2, 3).

4.3 In addition to ceramics and ceramic composites, the velocity measurements described herein may be applied to polycrystalline and single crystal metals, metal matrix composites, and polymer matrix composites.

4.4 An alternative technique for velocity measurement is given in Practice E494.

5. Personnel Qualifications

5.1 If specified in the contractual agreement, personnel performing examinations to this practice shall be qualified in accordance with a nationally or internationally recognized NDT personnel qualification practice or standard such as ANSI/ASNT-CP-189, SNT-TC-1A, NAS 410, ISO 9712, or a similar document and certified by the employer or certifying agency, as applicable. The practice or standard used and its applicable revision shall be identified in the contractual agreement between the using parties.

5.2 Knowledge of the principles of ultrasonic testing is required. Personnel applying this practice should be experienced practitioners of ultrasonic examinations and associated methods for signal acquisition, processing, and interpretation.

5.3 Personnel should have proficiency in computer signal processing and the use of digital methods for time and frequency domain signal analysis. Familiarity with Fourier and associated transforms for ultrasonic spectrum analysis is required.

6. Qualification of Nondestructive Agencies

6.1 If specified in the contractual agreement, NDT agencies shall be qualified and evaluated as described in Specification E543. The applicable edition of Specification E543 shall be specified in the contractual agreement.

7. Apparatus and Test Sample

7.1 Instrumentation (Fig. 1 and Fig. 2) for broadband cross-correlation pulse-echo ultrasonic velocity measurement should include the following:

7.1.1 Buffered Probe:

7.1.1.1 The buffer rod, which is an integral part of the probe (search unit), should be a right cylinder with smooth flat ends normal to the axis of the probe.

7.1.1.2 The center frequency of the buffered probe should produce a wavelength within the sample that is less than one fifth of the thickness of the sample.

7.1.1.3 The buffer rod length, that is, time delay should be three times the interval between two successive back surface echoes.

7.1.1.4 The wave mode may be either longitudinal or shear.

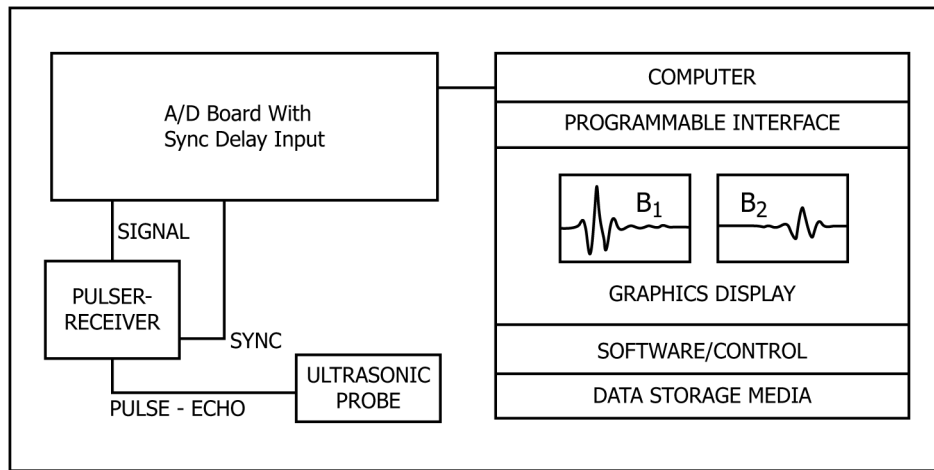

FIG. 2 Instrumentation Diagram for Acquiring and Separately Windowing Two Successive Back Surface Echoes, B_1 and B_2 , for Cross-Correlation Velocity Measurement

7.1.2 *Pulser-Receiver*, with a bandwidth that is at least twice that of the buffered probe. The bandwidth should include frequencies in the range from 100 kHz to over 100 MHz.

7.1.2.1 The pulser-receiver should have provisions for controlling the pulse repetition rate, pulse energy level, pulse damping, and received signal gain.

7.1.2.2 The pulser-receiver should provide a synchronization pulse and signal output connector.

7.1.3 *Waveform Digitizing Oscilloscope (A/D Board)*, bus programmable, to window and digitize the echo waveforms.

7.1.3.1 A minimum 512-element waveform array with a maximum data sampling interval of 1.95 ns is recommended. For better waveform resolution, a 1024-element array with a data sampling interval of 0.97 ns may be needed.

7.1.3.2 *Vertical Amplifier*, bus programmable module.

7.1.3.3 *Time Base*, bus programmable module with a resolution of at least 5 ns per division and several time base ranges including a fundamental time base of at least 200 ns.

7.1.4 *Digital Time Delay Module*, bus programmable, to introduce a known time delay between the start of two separate time gates, that is, windows each of which containing one of two successive back surface echoes.

7.1.4.1 Separate windows are preferred for waveform digitization. Each waveform should occupy from 60 % to 80 % of the window.

7.1.4.2 The time synthesizer should have an accuracy of ± 1 ns with a precision of ± 0.1 ns.

7.1.5 *Video Monitors*, (optional) one analog, one digital for real-time visual inspection of echo waveforms and for making interactive manual adjustments to the data acquisition controls.

7.1.6 *Computer*, with adequate speed and storage capacity to provide needed software control, data storage, and graphics capability. The software should include a fast Fourier transform (FFT) algorithm package containing the cross-correlation algorithm.

7.1.7 *Couplant Layer*, to establish good signal transfer between the buffer rod and test sample. The layer should be as thin as possible to minimize couplant resonances and distortion of the echo waveforms.

7.1.7.1 The couplant should not be absorbed by or be otherwise deleterious to the test sample.

7.1.7.2 Dry coupling with a thin polymer may be used where liquid contamination by or absorption of liquids by the test sample or part must be avoided.

7.2 The test sample or part should have flat parallel opposing surfaces in the region where the velocity measurements are made. This will assure good coupling between the transducer and sample and also produce valid echoes for velocity measurements.

7.2.1 Lack of precision in the measurement of the test sample thickness can undermine the nanosecond precision with which pulse-echo travel times can be measured. Therefore, the sample thickness should be measurable to an accuracy of ± 0.1 % or better.

7.2.2 For most engineering solids, the sample thickness should be at least 2.5 mm. There is a practical upper bound on sample thickness, for example, if the sample is too thick, there may be considerable signal attenuation, beam spreading, and dispersion that render the signal useless.

8. Procedure

8.1 Use instrument control software routines to start and control the interface bus; perform procedures such as optimizing intensity, voltage, and time on the waveform digitizing oscilloscope; control the digital time delay module; and acquire, store, and process data.

8.1.1 A cross-correlation algorithm should be part of the FFT software.

8.1.2 The arguments needed to implement the cross-correlation algorithm are the time domain waveform arrays, that is, digitized echoes B_1 and B_2 (Fig. 1).

8.2 Prepare samples with front and back surfaces that are sufficiently smooth, flat, and parallel to allow measurement of the test sample thickness to an accuracy of 0.1 % or better.

8.3 Couple the sample to the transducer to obtain two strong back surface echoes.