



Designation: **E2874 – 19** E2874 – 23

An American National Standard

Standard Test Method for Determining the Fire-Test Response Characteristics of a Building Spandrel-Panel Assembly Due to External Spread of Fire¹

This standard is issued under the fixed designation E2874; the number immediately following the designation indicates the year of original adoption or, in the case of revision, the year of last revision. A number in parentheses indicates the year of last reapproval. A superscript epsilon (ϵ) indicates an editorial change since the last revision or reapproval.

INTRODUCTION

This standard test method evaluates the ability of the spandrel-panel assembly in an exterior wall assembly, with or without glazing, to impede the spread of fire to the interior of the room or the story immediately above it via fire spread from the exterior of a building. A building spandrel-panel assembly includes the exterior wall spandrel-panel assembly and any glazing. The spandrel-panel assembly is a unique building construction detail not addressed by other fire test methods.

A building's spandrel-panel assembly impedes the vertical spread of fire from the floor of origin to the floor immediately above it, via an exterior fire exposure.

This test method describes criteria used to determine the fire performance of spandrel-panel assemblies when subjected to standard fire exposure conditions. This test method is intended to simulate a possible fire exposure due to a post flashover compartment fire venting through an opening, onto the exterior surface of a spandrel-panel assembly.

1. Scope

1.1 This test method evaluates the fire-test response characteristics of a spandrel-panel assembly spanning the intersection of a floor assembly.

1.2 This test method is used to assess the spandrel-panel assembly's ability to impede spread of fire to the interior of the room or the story immediately above it via fire spread from the exterior of a building, and provide a quantitative measure of the fire hazard in terms of an I-Rating, T-Rating, and F-Rating from a specified set of fire conditions involving specific materials, products, or assemblies.

1.3 This test evaluates the performance of the portions of the exterior wall installed between vertically adjacent window openings in multi-story buildings.

1.4 This test method addresses the potential for fire spread to a single story immediately above the room of fire origin.

1.5 The test method simulates a fire in a post-flashover condition in a compartment that is venting to the exterior through a window opening.

¹ This test method is under the jurisdiction of ASTM Committee E05 on Fire Standards and is the direct responsibility of Subcommittee E05.11 on Fire Resistance. Current edition approved Feb. 1, 2019; Nov. 1, 2023. Published March 2019; December 2023. Originally approved in 1919. Last previous edition approved in 1919 as E2874 – 19. DOI: 10.1520/E2874-19-10.1520/E2874-23.

1.6 The fire exposure conditions within the test room are those specified by this test method for the first 30 min of exposure and then conform to Test Methods [E119](#) time-temperature curve for the remainder of the test. The fire exposure on the exterior surface of the test specimen comprises both the exposure from the fire plume exiting the window opening of the test room and the exterior burner, although the fire exposure on the exterior surface of the test assembly is not equivalent to that of Test Methods [E119](#).

1.7 This test method specifies the heating conditions, methods of test, and criteria for evaluation of a building's spandrel-panel assembly. Specimens are not tested using any super-imposed axial load.

1.8 Test results establish the performance of the spandrel-panel assembly during the fire-exposure period and shall not be construed as having determined the suitability of a spandrel-panel assembly for use after that exposure.

1.9 This test method does not provide quantitative information about the spandrel-panel assembly relative to the rate of leakage of smoke or gases, or both.

1.9.1 This test method does not evaluate the fire-test-response characteristics of perimeter joint protection between the floor assembly and the exterior wall assembly. This is covered in Test Method [E2307](#).

1.10 This test method does not evaluate the fire-test-response characteristics or fire propagation propensity of material installed on, or within, exterior non-load-bearing wall assemblies containing combustible components. This is covered in NFPA 285.

1.11 The values stated in inch-pound units are to be regarded as the standard. Where provided, the SI values given in parentheses are for information only.

1.12 The text of this test method references notes and footnotes which provide explanatory material. These notes and footnotes (excluding those in tables and figures) shall not be considered as requirements of the standard.

1.13 *This test method is used to measure and describe the response of materials, products or assemblies to heat and flame under controlled conditions but does not by itself incorporate all factors required for the fire-hazard or fire-risk assessment of the materials, products, or assemblies under actual fire conditions.*

1.14 *This standard does not purport to address all of the safety concerns, if any, associated with its use. It is the responsibility of the user of this standard to establish appropriate safety, health, and environmental practices and determine the applicability of regulatory limitations prior to use.*

1.15 *Fire testing is inherently hazardous. Adequate safeguards for personnel and property shall be employed in conducting these tests.*

1.16 *This international standard was developed in accordance with internationally recognized principles on standardization established in the Decision on Principles for the Development of International Standards, Guides and Recommendations issued by the World Trade Organization Technical Barriers to Trade (TBT) Committee.*

2. Referenced Documents

2.1 ASTM Standards²

[E108](#) Test Methods for Fire Tests of Roof Coverings

[E119](#) Test Methods for Fire Tests of Building Construction and Materials

[E176](#) Terminology of Fire Standards

[E511](#) Test Method for Measuring Heat Flux Using a Copper-Constantan Circular Foil, Heat-Flux Transducer

[E631](#) Terminology of Building Constructions

[E1529](#) Test Methods for Determining Effects of Large Hydrocarbon Pool Fires on Structural Members and Assemblies

[E1966](#) Test Method for Fire-Resistive Joint Systems

[E2307](#) Test Method for Determining Fire Resistance of Perimeter Fire Barriers Using Intermediate-Scale, Multi-story Test Apparatus

² For referenced ASTM standards, visit the ASTM website, www.astm.org, or contact ASTM Customer Service at service@astm.org. For *Annual Book of ASTM Standards* volume information, refer to the standard's Document Summary page on the ASTM website.

2.2 NFPA Standard:³

NFPA 285 Standard Method of Test for the Evaluation of Flammability Characteristics of Exterior Non-Load-Bearing Wall Assemblies Containing Combustible Components Using the Intermediate-Scale, Multistory Test Apparatus

3. Terminology

3.1 Terms defined in Terminology **E176** and **E631** shall prevail for fire standard and building terms not defined in this document.

3.2 *exterior wall assembly, n*—a non-load bearing or load bearing wall located on the exterior of a building that is either fire resistance rated or one that is not.

3.3 *floor assembly, n*—a fire resistance rated load bearing horizontal assembly which is either adjacent, or part of the floor of the observation room.

3.3.1 Discussion—

Floor assemblies tested in accordance with Test Methods **E119** are required to be load bearing.

3.4 *integrity rating, n*—ability of the spandrel-panel assembly to prevent the passage of flame and hot gases through it, and the occurrence of flames on its unexposed side.

3.5 *observation room, n*—the second-story room of the Intermediate-Scale, Multi-story Test Apparatus (ISMA).

3.6 *spandrel-panel assembly, n*—the portion of a building's exterior wall assembly, which is comprised of the spandrel-panel, fasteners, structural supports and any glazing, located between the top of the window opening in one story and the sill of the window opening one adjacent story immediately above.

3.6.1 Discussion—

The term “spandrel-panel” is a commonly used architectural term. When used in conjunction with a curtain wall, this term is defined by *The Oxford Dictionary of Architecture (3rd ed.)*,⁴ as follows: Part of a wall between the head of a window-aperture and the sill of the window above in a building of two or more stories, especially in a curtain-wall.

3.7 *test assembly, n*—the complete assembly of the test specimen together with the test apparatus.

3.8 *test room, n*—the first-story room of the ISMA. [ASTM E2874-23](https://standards.iteh.ai/catalog/standards/astm/cfb35b56-de95-45dc-9d45-6299deb497cd/astm-e2874-23)

<https://standards.iteh.ai/catalog/standards/astm/cfb35b56-de95-45dc-9d45-6299deb497cd/astm-e2874-23>

3.9 *test specimen, n*—the specific design details of the spandrel-panel assembly evaluated during the test.

4. Summary of Test Method

4.1 This test method describes the following test sequence and procedure:

4.1.1 A spandrel-panel assembly is conditioned and fire tested.

4.1.2 During the fire test, the performance of the spandrel-panel assembly is determined by use of a cotton pad; the resistance to flames and hot gases is determined by visual observations; the resistance to heat transfer is determined by unexposed surface temperature measurements; and heat flux is determined using radiometers.

4.2 The end point of the fire test occurs at the time the first interpretation of results is reached when the spandrel-panel assembly is subjected to the time-temperature fire exposure described in this test method.

5. Significance and Use

5.1 This test method provides for the following measurements and evaluations:

5.1.1 Ability of the spandrel-panel assembly to resist the passage of flames or hot gases sufficient to ignite a cotton pad, or be visible to an observer.

³ Available from National Fire Protection Association (NFPA), 1 Batterymarch Park, Quincy, MA 02169-7471, <http://www.nfpa.org>.

⁴ James Stevens Curl and Susan Wilson, Oxford University Press, 2015. Originally published by Oxford University Press in 2000.

5.1.2 Transmission of heat through, and above, the spandrel-panel assembly using heat flux and unexposed surface temperature measurements.

5.2 This test method does not provide the following:

5.2.1 This test method does not evaluate the fire propagation characteristics of exterior nonload-bearing wall assemblies containing combustible components, or flame spread over the test assembly.

5.2.2 This test method does not evaluate the fire-test-response characteristics of the perimeter joint protection between the floor assembly and the exterior wall assembly. This is covered in Test Method [E2307](#).

5.2.3 Evaluation of the degree to which the spandrel-panel assembly contributes to the fire hazard by generation of smoke, toxic gases, or other products of combustion,

5.2.4 Measurement of the degree of control or limitation of the passage of smoke or products of combustion through the spandrel-panel assembly,

5.2.5 Measurement of flame spread over the surface of the spandrel-panel assembly or exterior wall assembly,

5.2.6 Durability of the test specimen under actual service conditions, including the effects of cycled temperature,

5.2.7 Effects of loads (for example, wind, seismic, etc.) on the spandrel-panel assembly established by this test method,

5.2.8 Movement capabilities of the test specimen,

5.2.9 Other attributes of the test specimen, such as wear resistance, chemical resistance, air infiltration, water-tightness, and so forth, and

5.2.10 Lateral spread of flame from the compartment of fire origin to adjacent spaces.

5.3 In this test method, the test specimens are subjected to one or more specific test conditions. When different test conditions are substituted or the end-use conditions are changed, it is not always possible by, or from, this test method to predict changes to the characteristics measured.

5.4 This test method is not intended to be used as the only test method in the selection of a spandrel-panel assembly. It is not intended as a specification for all attributes required by a spandrel-panel assembly, or any of its individual components, in order for a spandrel-panel assembly to be used in a particular application.

6. Apparatus

6.1 The test apparatus described in [6.2](#) shall be located inside a test facility. The facility shall have provisions for supplying fresh combustion make-up air during the test. The facility shall be constructed to allow for the exhaust of the combustion by-products during the test, while not inducing airflow on the exterior face of the test specimen. The test facility shall protect the test apparatus and test specimen from weather conditions such as wind and rain.

6.2 Test Apparatus:

6.2.1 The ISMA consists of a two-story test structure consisting of a test room and observation room (See [Fig. 1](#)). Each room in the test apparatus is square having inside length and width dimensions (unfinished and unprotected by any fire resistive materials) of 120 ± 0.5 in. (3048 ± 13 mm) and a height (unfinished and unprotected by any fire resistive materials) of 84 ± 0.5 in. (2134 ± 13 mm).

NOTE 1—The test apparatus is similar to the one used in NFPA 285 and Test Method [E2307](#).

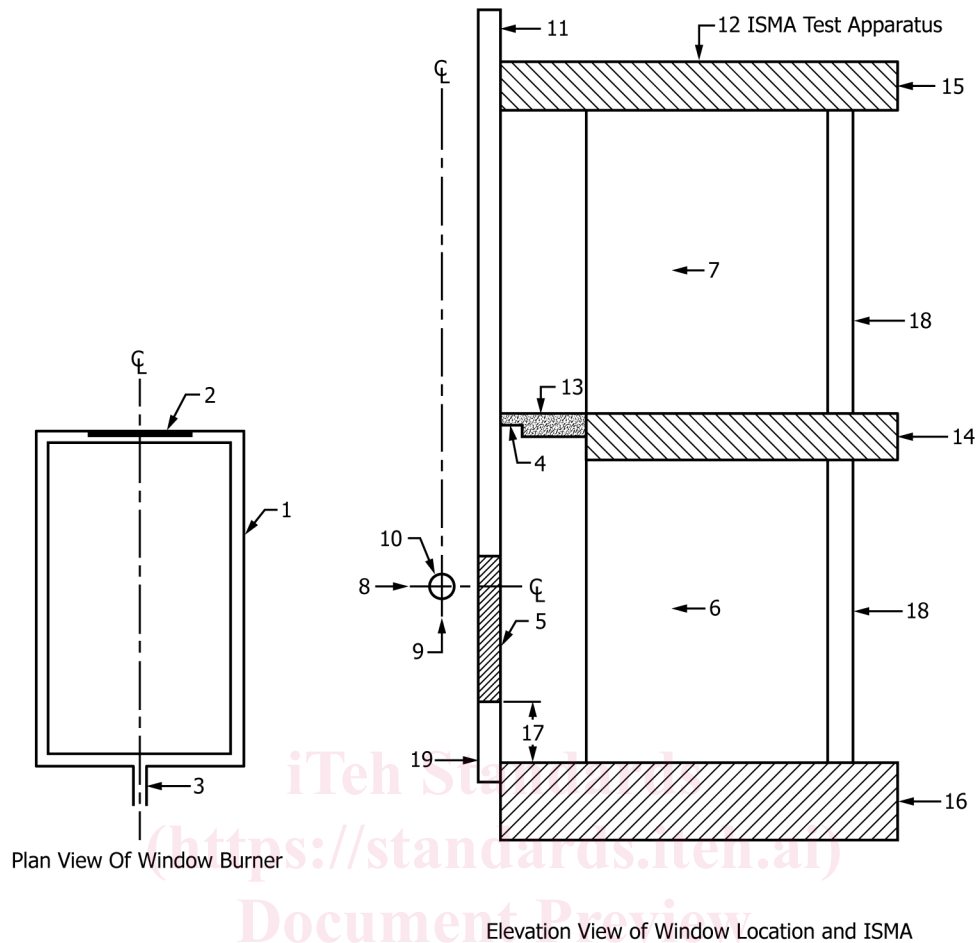

1. Window Burner (see 6.3.3)
2. Slot in Window Burner (see 6.3.3.2)
3. Gas Supply Line for Window Burner (see 6.3.3.3)
4. Joint from Floor Assembly to Exterior Wall (see 7.4)
5. Window (see 7.2.9)
6. Test Room in Test Apparatus (see 3.8)
7. Observation Room in Test Apparatus (see 3.5)
8. Horizontal Centerline of Burner (see 6.3.3.5)
9. Vertical Centerline of Burner (see 6.3.3.5)
10. Window Burner Location (see 6.3.3.5)
11. Exterior Wall Assembly or Calibration Wall (see 7.2 and 9.2)
12. Test Apparatus (ISMA) (see 6.2)
13. Floor of the Assembly (see 7.3)
14. Floor of the Observation Room (see 7.3)
15. Roof Slab (see 6.2.2)
16. Floor of Test Room (see 6.2.2)
17. Window Sill Height (see 7.2.9.2)
18. Non-Bearing Walls (see 6.2.3)
19. Bottom of Exterior Wall (see 7.2.7.1)

FIG. 1 View of Window Burner and the Elevation View of the ISMA Test Apparatus (see 6.2)

6.2.2 The floors and roof of the test apparatus shall be supported by columns and beams of a size that will support the load of the floor and roof. These supports shall be located outside of both the test room and the observation room. (See Fig. 2 and Fig. 3.)

6.2.3 The three permanent non-bearing walls that form each room of the test apparatus shall support the insulation defined in 6.2.4.1 during the entire fire test.

NOTE 2—Concrete block, 8 ± 0.5 in. (203 ± 13 mm) thick, has been found to be acceptable.

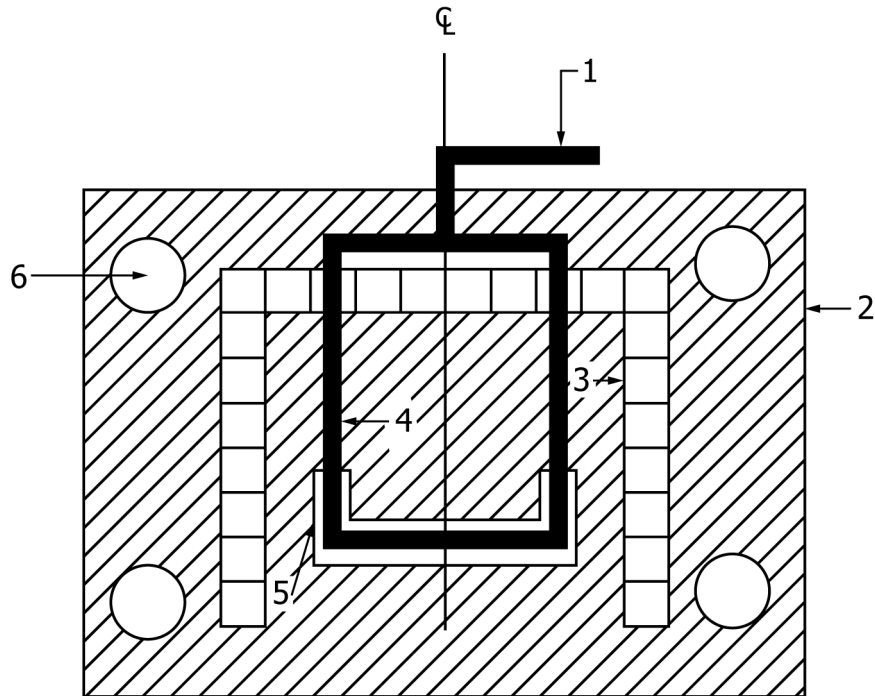

1. Gas Supply Line (see 6.3.2)
2. Concrete Slab (Floor of Test Room (see 6.2.2))
3. Walls (see 6.2.3)
4. Test Room Burner (see 6.3.2)
5. Area of Burner Holes (see 6.3.2.3)
6. Columns (see 6.2.2)

FIG. 2 Plan View of Test Room Burner Positioned in Test Room (see 6.3.1 for dimensions)

6.2.4 No insulation is required in the observation room; but the interior surfaces of the test room shall be insulated.

6.2.4.1 Insulate the interior face of the walls forming the test room with one layer of 2.0 ± 0.5 in. (51 ± 13 mm) thick ceramic fiber insulation, having a minimum density of 8 lb/ft^3 (128 kg/m^3). Insulate the underside of the floor of the observation room in the same manner, except that the portion that is designated the “floor assembly,” which is adjacent to the test specimen, shall not be insulated (See Fig. 1 and 7.4).

6.2.4.2 Insulate the floor of the test room with two layers of nominal 0.625-in. (15.9-mm) thick, Type X gypsum wallboard.

6.2.5 Openings are permitted in the test room and in the observation room.

6.2.5.1 The observation room shall have one access opening with a width and height of nominal 3.5 by 6.75 ft (1.07 by 2.06 m). The access opening shall remain open during tests. Additional access openings are permitted in the observation room for instrumentation and video; however, they shall be closed during the test.

6.2.5.2 The test room is permitted to have one access opening with a width and height of nominal 3.5 by 6.75 ft (1.07 by 2.06 m). This opening shall be closed during tests.

6.3 Burners:

6.3.1 The test apparatus in 6.2 shall be equipped with two gas-fired burners.

6.3.2 Test Room Burner:

6.3.2.1 Position the test room burner inside the test room. Construct the test room burner (See Fig. 2) as follows:

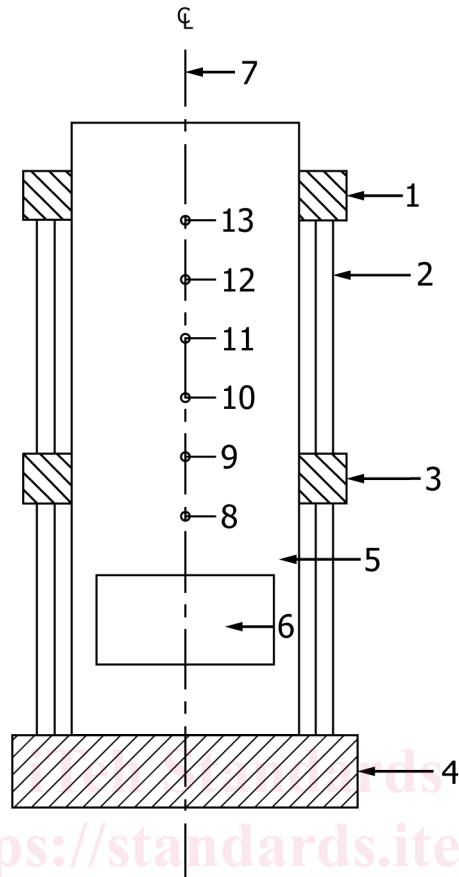

1. Roof Slab (see 6.2.2)
2. Columns (Typical) (see 6.2.2)
3. Floor of Observation Room (see 7.3)
4. Floor of Test Room (see 6.2.4.2)
5. Exterior Face of Calibration Wall (see 9.2.1)
6. Window Opening (see 6.2.2)
7. Horizontal Centerline of Calibration Wall (see 9.2.3)
8. Thermocouple #1 Location (see 9.4.2.1)
9. Thermocouple #2 Location (see 9.4.2.2)
10. Thermocouple #3 and Lower Heat Flux Location (see 9.4.2.3 and 9.5.2)
11. Thermocouple #4 and Middle Heat Flux Location (see 9.4.2.3 and 9.5.2)
12. Thermocouple #5 and Upper Heat Flux Location (see 9.4.2.3 and 9.5.2)
13. Thermocouple #6 Location (see 9.4.2.2)

NOTE 1—Item 6 for Window Opening, reference should be made to 7.2.9 for window opening information.

NOTE 2—Item 13 for Thermocouple #6 Location, refer to 9.4.2.3 which refers to the successive placement of thermocouples after the second thermocouple.

FIG. 3 ISMA and Calibration Wall Layout for Thermocouple and Heat Flux Locations (see 6.2 and 9.2)

6.3.2.2 Use a nominal 2-in. (51-mm) OD steel pipe. The test room burner shall be rectangular shaped with its longitudinal axis at least 78.75 in. (2000 mm) long and its transverse axis at least 60 in. (1524 mm) wide. Extend 72 ± 1 in. (1829 ± 25 mm) of the test room burner into the test room.

6.3.2.3 Drill upward facing nominal diameter 0.125-in. (3.2-mm) holes in the pipe. Locate the holes in the front “U” shaped portion of the test room burner. Start holes at a nominal location of 42 in. (1066 mm) from the back wall on both sides of the gas supply pipes and continue across the front gas supply pipe. Place the holes nominally 1 in. (25 mm) on center.

NOTE 3—The holes drilled are nominal because they are made using a conventional 1/8-in. drill bit, therefore, their size is dependent upon the tolerances of the drill bit.

6.3.2.4 Support the test room burner so that it is level and its horizontal centerline is 30 ± 1 in. (762 ± 25 mm) above the floor of the test room.

6.3.2.5 Center the test room burner in the test room using [Fig. 2](#) for reference.

6.3.2.6 Equip the test room burner with a gas supply line that is located outside the test apparatus. Wrap the entire gas supply pipe system with a single layer of nominal 1-in. (25-mm) thick ceramic fiber blanket, with a minimum density of 8 lb/ft³ (128 kg/m³).

6.3.3 *Window Burner:*

6.3.3.1 Construct the window burner (See [Fig. 1](#)) as follows:

NOTE 4—The window burner is similar to the one used in U.B.C. Standard No. 26-9, Test Method [E2307](#), and NFPA 285 and is similar to the burner used in the “Spread of Flame Test” portion of Test Methods [E108](#).

6.3.3.2 The window burner shall be rectangular shaped. Use a 60 ± 0.5-in. (1524 ± 13-mm) long piece of nominal 2-in. (51-mm) OD pipe for the front of the burner. Cut an upward facing slot having a width and length measuring 0.5 ± 0.06 in. (13 ± 1.5 mm) by 44 ± 0.5 in. (1118 ± 13 mm), respectively, in the top of the pipe.

6.3.3.3 Supply the window burner with gas at both ends using nominal 1-in. (25-mm) OD pipe and a “T” junction at the back of the window burner to provide uniform gas pressure at the burner slot.

6.3.3.4 Wrap the window burner, including the slot, and the entire gas supply pipe system with a layer of nominal 1-in. (25-mm) thick ceramic fiber insulation, with a minimum density of 8 lb/ft³ (128 kg/m³).

6.3.3.5 Position the window burner so that the slot is facing up and parallel with the exterior wall assembly. Align the horizontal center of the window burner slot with the window’s horizontal centerline (See [Fig. 1](#)). Locate the horizontal centerline of the window burner 9 ± 0.5 in. (229 ± 13 mm) below the window header’s surface on the exterior of the test room. Place the window burner’s vertical centerline a maximum of 6 in. (152 mm) from the exterior face of the exterior wall assembly. The window burner’s exact distance from the wall’s exterior face of the exterior wall assembly shall be determined during the calibration procedure, as specified in [9.6](#).

6.4 *Test Room and Exterior Wall Assembly Thermocouples:*

6.4.1 All thermocouples shall be a bare wire type. [ASTM E2874-23](#)

6.4.2 The twelve test room thermocouples used to measure the temperatures in the test room, reference the thermocouples in [8.1](#), [8.1.1](#), and [8.1.2](#), shall be 18 gauge Type K (See [Fig. 3](#)).

6.4.3 The 14 exterior wall assembly thermocouples used to measure the temperatures on the exterior face of the exterior wall assembly shall be and calibration wall assemblies shall be no larger than 20 gauge Type K-K (See [Fig. 4](#)).

6.5 *Copper Disc Thermocouples:*

6.5.1 The copper disc thermocouples shall be covered by pads as specified in [6.7](#), and shall:

6.5.1.1 Have a wire diameter of not more than 0.03 in. (0.7 mm), and

6.5.1.2 Be brazed to the center of the face of a copper disk having the following nominal measurements: 0.5 in. (12 mm) diameter and 0.008 in. (0.2 mm) thick.

6.6 *Thermocouple Insulating Pads:*

6.6.1 Refractory fiber pads shall have the following properties:

6.6.1.1 Length and width, 1.20 ± 0.02 in. (30 ± 0.5 mm).

6.6.1.2 Thickness, 0.08 ± 0.02 in. (2 ± 0.5 mm). The thickness measurement shall be made using a ½-in. (13-mm) diameter, anvil head micrometer, without compression of the pad.

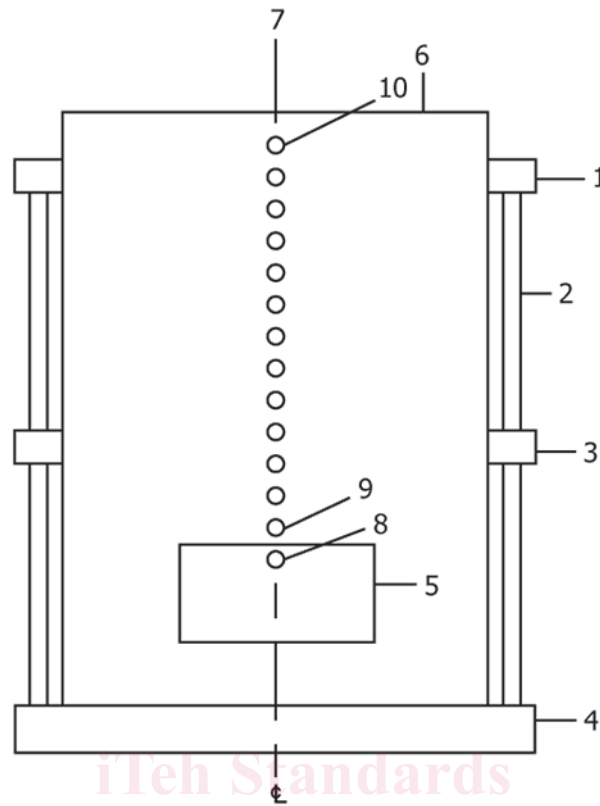

(1) Roof Slab (Ref. 6.2.2)

(2) Column (Ref. 6.2.2)

(3) Floor of Observation Room (Ref. 6.2.2)

(4) Floor of Test Room (Ref. 6.2.2)

(5) Window Opening (Ref. 9.2.2)

(6) Visual Face of Calibration Wall (Ref. 9.2)

(7) Vertical Centerline of Test Wall (Ref. 9.4.2)

(8) Thermocouple #1 Location (Ref. 9.4.2.1)

(9) Thermocouple #2 Location (Ref. 9.4.2.2)

(10) Thermocouple #6 Location (Ref. 9.4.2.4)

FIG. 4 Thermocouple Layout on Visual Exterior Face of Calibration or Test Wall (See 9.4)

6.6.1.3 Density of $56.2 \pm 6.2 \text{ lb/ft}^3$ ($900 \pm 100 \text{ kg/m}^3$).

6.6.1.4 Density of $56.2 \pm 6.2 \text{ lb/ft}^3$ ($900 \pm 100 \text{ kg/m}^3$).

6.6.2 When necessary, shape the pads by wetting, forming, and then drying them to provide complete contact on contoured surfaces.

6.7 Heat Flux Measurements:

6.7.1 A Schmidt-Boelter (thermopile) type heat flux meter with a nominal range of 0 to 50 kW/m^2 and a time constant of not more than 3 s (corresponding to a time to reach 95 % of final output of not more than 10 s) shall be provided. The heat flux meter's sensing surface shall be flat, be less than 0.4 in. (10 mm) diameter, be coated with a durable matt black finish, and shall not be closed with a transparent cover.

NOTE 5—Commercially available heat flux meters are commonly referred to as “heat flux transducers” or “heat flux gauges.”

6.7.2 Locate the heat flux meter either ± 6 in. (152 mm) from the vertical centerline of the window opening, or, where a center mullion is installed in the story above the window opening in the test apparatus, ± 6 in. (152 mm) horizontally from the edge of the center mullion.

6.7.3 Where a spandrel-panel or transom is installed as part of the test specimen, the heat flux meter shall be located at a height of 6 ± 0.5 in. (152 ± 13 mm) vertically above the top of the spandrel-panel or transom.

6.7.4 Except as required in 6.7.3, the heat flux meter shall be installed at a height of 12 ± 0.5 in. (305 ± 13 mm) above the unexposed surface of the observation room floor.

6.7.5 Locate the measuring surface of the heat flux meter in the observation room, at the required height, in a plane 4 ± 0.25 in. (102 ± 6 mm) from the interior face of the test specimen.

6.7.6 Recorder—The output from the heat flux meter shall be recorded by a strip chart recording millivoltmeter, computer data logger, or other comparable method.

NOTE 6—A digital voltmeter capable of indicating signal changes of $10 \mu\text{V}$ has been found to be convenient for monitoring changes in operating conditions of the radiant panel. A strip chart recorder with a paper speed of 12 in./min (5 mm/s) has been found to be suitable.

6.7.7 Timing Devices—A chronograph and either an electric clock with a sweep second hand or a digital clock shall be used to measure time to ignition and to track the advancement of the flame front with time.

6.8 Cotton Pads:

6.8.1 The cotton pad's nominal size shall be 4 by 4 by 0.75 in. (100 by 100 by 19 mm). Cotton pads are to consist of new, undyed, and soft cotton fibers, without any admixture of artificial fibers. Each cotton pad shall weigh 3 to 4 g. The cotton pads are to be conditioned prior to use by drying in an oven at 212 ± 9 °F (100 ± 5 °C) for at least 30 h. After drying, the cotton pads shall be stored in a desiccator for up to 24 h immediately prior to use.

6.8.2 The frame used to hold the cotton pad is to be formed of No. 16 AWG (1.31-mm) steel wire and is to be provided with a handle that will reach all points of the test specimen accessible from the observation room (See Fig. 45).

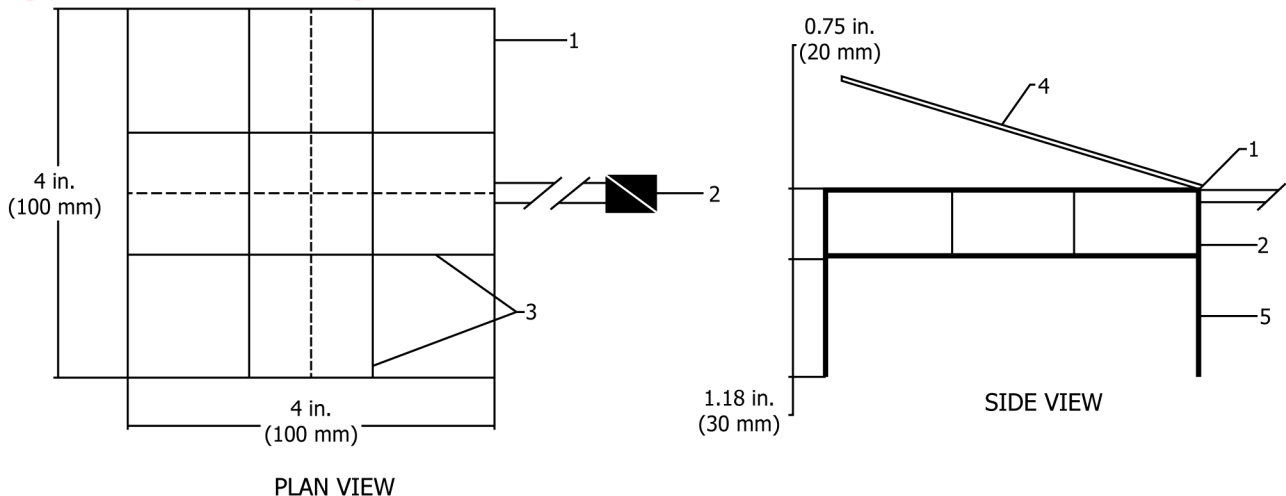

- 1. Hinge
- 2. Handle
- 3. 21 Gage (0.5 mm) Diameter Street Wire
- 4. Hinged Lid with Latch
- 5. 16 Gage (1.31 mm) Diameter Steel Wire Framework

Note 1: Solid lines illustrate the framework.
 Note 2: Dashed lines illustrate the hinged lid.

FIG. 45 Typical Cotton Wool Pad Holder (see 6.8.2)