



SLOVENSKI STANDARD  
SIST EN 12332-1:1999

01-marec-1999

; i a [fUbYU]d`UghZVfUbYHY\_gH]`Y`I [ cHUj`Ub`YfUndc bYhfXbcgh]!`%`XY.  
AYfcXUn`Y`Ybc`\_fc[`Wc

Rubber- or plastic-coated fabrics - Determination of bursting strength - Part 1: Steel ball method

Mit Kautschuk oder Kunststoff beschichtete Textilien - Bestimmung der Berstfestigkeit - Teil 1: Stahlkugelfverfahren

Supports textiles revetus de caoutchouc ou de plastique - Détermination de la résistance a l'éclatement - Partie 1: Méthode a la bille

ITeH STANDARD PREVIEW  
(standards.iteh.ai)

<https://standards.iteh.ai/catalog/standards/sist/7b4c3868-e6b8-4097-b78d-b6f5ec90b261/sist-en-12332-1-1999>

Ta slovenski standard je istoveten z: EN 12332-1:1998

**ICS:**

59.080.40 Ú[ ç:zã •\ [ Á !^ç|^ ^} ^ Coated fabrics  
e\ • çã

SIST EN 12332-1:1999 en

**iTeh STANDARD PREVIEW**  
**(standards.iteh.ai)**

SIST EN 12332-1:1999

<https://standards.iteh.ai/catalog/standards/sist/7b4c3868-e6b8-4097-b78d-b6f5ec90b261/sist-en-12332-1-1999>

EUROPEAN STANDARD  
NORME EUROPÉENNE  
EUROPÄISCHE NORM

EN 12332-1

July 1998

ICS 59.080.40

Descriptors: textiles, coated fabrics, fabrics coated with rubber, fabrics coated with plastics, burst tests, determination, bursting strength

English version

## Rubber- or plastic- coated fabrics - Determination of bursting strength - Part 1: Steel ball method

Supports textiles revêtus de caoutchouc ou de plastique -  
Détermination de la résistance à l'éclatement - Partie 1:  
Méthode à la bille

Mit Kautschuk oder Kunststoff beschichtete Textilien -  
Bestimmung der Berstfestigkeit - Teil 1:  
Stahlkugilverfahren

This European Standard was approved by CEN on 21 June 1998.

CEN members are bound to comply with the CEN/CENELEC Internal Regulations which stipulate the conditions for giving this European Standard the status of a national standard without any alteration. Up-to-date lists and bibliographical references concerning such national standards may be obtained on application to the Central Secretariat or to any CEN member.

This European Standard exists in three official versions (English, French, German). A version in any other language made by translation under the responsibility of a CEN member into its own language and notified to the Central Secretariat has the same status as the official versions.

CEN members are the national standards bodies of Austria, Belgium, Czech Republic, Denmark, Finland, France, Germany, Greece, Iceland, Ireland, Italy, Luxembourg, Netherlands, Norway, Portugal, Spain, Sweden, Switzerland and United Kingdom.



EUROPEAN COMMITTEE FOR STANDARDIZATION  
COMITÉ EUROPÉEN DE NORMALISATION  
EUROPÄISCHES KOMITEE FÜR NORMUNG

Central Secretariat: rue de Stassart, 36 B-1050 Brussels

## Foreword

This European Standard has been prepared by Technical Committee CEN/TC 248 "Textiles and textile products", the secretariat of which is held by BSI.

This European Standard shall be given the status of a national standard, either by publication of an identical text or by endorsement, at the latest by January 1999, and conflicting national standards shall be withdrawn at the latest by January 1999.

EN 12332 deals with the determination of the bursting strength of coated fabrics. It consists of two Parts :

- Part 1 Steel ball method
- Part 2 Hydraulic method

NOTE. Persons using this standard should be familiar with normal laboratory practice. This standard does not purport to address all of the safety problems, if any, associated with its use. It is the responsibility of the user to establish appropriate safety and health practices and to ensure compliance with any national regulatory conditions.

**iTeh STANDARD PREVIEW**

According to the CEN/CENELEC Internal Regulations, the national standards organizations of the following countries are bound to implement this European Standard: Austria, Belgium, Czech Republic, Denmark, Finland, France, Germany, Greece, Iceland, Ireland, Italy, Luxembourg, Netherlands, Norway, Portugal, Spain, Sweden, Switzerland and the United Kingdom.



## 1. Scope

This Part of EN 12232 describes a method for determining the bursting strength of coated fabrics using a mechanically operated steel ball.

## 2 Normative references

This European Standard incorporates by dated or undated reference, provisions from other publications. These normative references are cited at the appropriate places in the text and the publications are listed hereafter. For dated references, subsequent amendments to or revisions of any of these publications apply to this European Standard only when incorporated by amendment or revision. For undated references the latest edition of the publication referred to applies.

EN ISO 2231 Rubber- or plastics coated fabrics - Standard atmospheres for conditioning and testing.

EN ISO 2286 Rubber- or plastics coated fabrics - Determination of roll characteristics.

ISO 1302 Technical drawings - Method of indicating surface texture.

ISO 7500-1 Metallic materials - Verification of static uniaxial testing machines . Part 1 : Tensile testing machines.

SIST EN 12332-1:1999

<https://standards.iteh.ai/catalog/standards/sist/7b4c3868-e6b8-4097-b78d-b6f5ec90b261/sist-en-12332-1-1999>

## 3 Principle

A coated fabric is securely clamped between rigid coaxial apertures. A polished steel ball, traversing at a fixed speed, is pressed against the coated fabric specimen until failure occurs. The force required to cause failure and the displacement of the polished steel ball at failure are recorded.

## 4 Apparatus

**4.1 Constant rate of extension (CRE) tensile testing machine**, having the following characteristics :

- a) A traverse speed of  $(5,0 \pm 0,5)$  mm/s;
- b) A force range such that the failure force of the fabric under test shall be between 10% and 90% of the upper force limit;
- c) The accuracy of the force-measuring system and the relative resolution of the force indicator shall conform to the maximum permissible values for a Class 1 machine as specified in ISO 7500-1;
- d) Autographic recorder.

## 4.2 Bursting attachment (see figure 1)

The test specimen is held securely by a ring mechanism of internal diameter  $(45 \pm 0,5)$  mm, when the centre of the test specimen is pressed against a polished steel ball of diameter  $(38 \pm 0,02)$  mm. The surface of the steel ball has an upper limit of the surface roughness parameter  $R_a$  of  $0,4 \mu\text{m}$  (roughness grade number N5) as described in ISO 1302. The direction of motion of the ring clamp or steel ball shall be at right angles to the plane of the fabric.

The clamping surfaces of the upper and lower clamps are grooved concentrically so that the crowns of the grooves of one plate fit the grooves of the other. The grooves are not less than 0,3 mm apart and not less than 0,15 mm deep. The grooves start no further than 3 mm from the edge of the aperture and are rounded to a radius of not greater than 0,4 mm. The lower inner edge of the lower clamp is rounded to a radius of 0,5 mm.

## 5 Test specimens

### 5.1 Preparation of test specimens

Cut six test specimens with a diameter of not less than 65 mm, in a diagonal arrangement across the full usable width of the coated fabric, in accordance with EN ISO 2286 (see figure 2).

(standards.iteh.ai)

### 5.2 Conditioning

Pre-condition the test specimens in accordance with EN ISO 2231, but do not expose specimens to a temperature above  $50^\circ\text{C}$ . Condition the test specimens for at least 24 h in one of the standard atmospheres for testing coated fabrics according to EN ISO 2231, ensuring exposure of all the surfaces to the air by, for example, placing the test specimens on wire-gauze or mesh.

When it is required to determine the properties of wet material, immerse each previously cut test specimen in distilled or de-ionised water and place under vacuum for 10 min. Immediately after removal from the water, blot each test specimen between two sheets of absorbent paper and test at once.

## 6 Procedure

Secure the test specimen in the ring clamp such that the coated side of the fabric faces away from the steel ball and apply a pretension load of  $(5,0 \pm 0,5)$  N to the test specimen. Engage the autographic recorder and move the test specimen and steel ball towards each other at a speed of  $(5,0 \pm 0,5)$  mm/s until the test specimen fails.

NOTE. For fabrics coated on both faces, an agreement on the face to be tested should be achieved, otherwise it is recommended to test both faces and

NOTE. For fabrics coated on both faces, an agreement on the face to be tested should be achieved, otherwise it is recommended to test both faces and indicate this deviation in the test report. If the uncoated face is the external face in use, the testing authority should be especially asked to test the material with the uncoated surface outside and this deviation noted in the report.

## 7 Assessment of failure

Ignore any failure that is confined to the edge of the clamp and repeat the test on another test specimen.

Ignore any test results where the test specimen slips in the clamp and repeat the test on another test specimen.

NOTE: Slippage is normally evident as blurring of the marks left by the ring clamp on the test specimen.

Many tensile machines automatically record the maximum force reached during a test and the distension at this point. However, certain types of coated fabrics are known to fail progressively with a number of peak forces until the fabric is completely penetrated. In such cases the first peak recorded shall be regarded as the failure point of the fabric. The first peak is not necessarily the maximum force recorded during a test and can only be determined from an autographic recording of force against distension. Tensile testing machines which are capable of automatically recording zero slope yield points may detect low first peaks but it is recommended that an autographic recording is obtained for all tests.

## 8 Calculation and expression of results

For each test, record the force in newtons required to cause the failure of the test specimen to the nearest newton.

Calculate the arithmetic mean of the six results obtained.

For each test, record the displacement of the steel ball required to cause the failure of the test specimen, in millimetres, to the nearest 0,1 mm.

Calculate the arithmetic mean of the six results obtained.

## 9 Test report

The test report shall include the following particulars :

- a) reference to this European Standard;
- b) simple designation of the tested material;
- c) the conditioning atmosphere used, or whether the specimens were tested in the wet state;
- d) date of test;
- e) number of specimens evaluated;
- f) the bursting strength in newtons as the mean of the six results obtained;
- g) the bursting distension in millimetres as the mean of the six results obtained;
- h) standard deviation and confidence interval, if required;
- i) details of any deviations from the standard test procedure.

**iTeh STANDARD PREVIEW**  
**(standards.iteh.ai)**

SIST EN 12332-1:1999

<https://standards.iteh.ai/catalog/standards/sist/7b4c3868-e6b8-4097-b78d-b6f5ec90b261/sist-en-12332-1-1999>



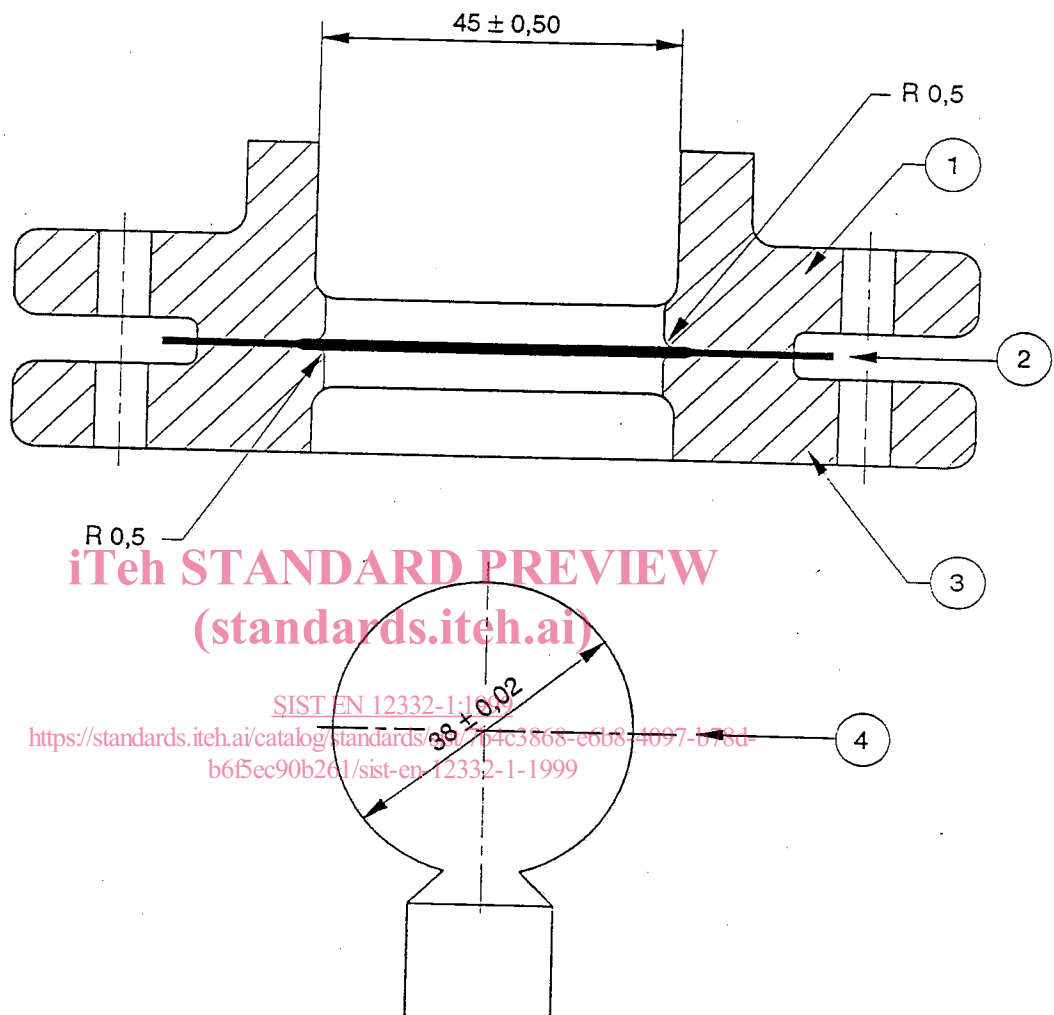

- 1 Upper clamp
- 2 Test specimen
- 3 Lower clamp
- 4 Steel ball

All dimensions are in Millimetres

**Figure 1. Apparatus**