

---

# INTERNATIONAL STANDARD



# 5620

---

INTERNATIONAL ORGANIZATION FOR STANDARDIZATION • МЕЖДУНАРОДНАЯ ОРГАНИЗАЦИЯ ПО СТАНДАРТИЗАЦИИ • ORGANISATION INTERNATIONALE DE NORMALISATION

---

## Shipbuilding — Filling connection for drinking water tanks on ships

*Construction navale — Raccordement de remplissage des réservoirs à eau potable des navires*

First edition — 1978-07-01

**iTeh STANDARD PREVIEW**  
**(standards.itih.ai)**

[ISO 5620:1978](https://standards.itih.ai/catalog/standards/sist/1a37b916-480f-4ed7-ac9b-46675893953f/iso-5620-1978)

<https://standards.itih.ai/catalog/standards/sist/1a37b916-480f-4ed7-ac9b-46675893953f/iso-5620-1978>

---

UDC 629.12 : 621.643

Ref. No. ISO 5620-1978 (E)

**Descriptors** : shipbuilding, pipelines, water pipelines, pipe joints, water supply, potable water.

Price based on 4 pages

## FOREWORD

ISO (the International Organization for Standardization) is a worldwide federation of national standards institutes (ISO member bodies). The work of developing International Standards is carried out through ISO technical committees. Every member body interested in a subject for which a technical committee has been set up has the right to be represented on that committee. International organizations, governmental and non-governmental, in liaison with ISO, also take part in the work.

Draft International Standards adopted by the technical committees are circulated to the member bodies for approval before their acceptance as International Standards by the ISO Council.

International Standard ISO 5620 was developed by Technical Committee ISO/TC 8, *Shipbuilding*, and was circulated to the member bodies in April 1977.

It has been approved by the member bodies of the following countries :

Australia	Germany	Poland
Austria	India	Romania
Belgium	Italy	Spain
Brazil	Japan	Sweden
Bulgaria	Korea, Dem. P. Rep. of	Turkey
Chile	Korea, Rep. of	United Kingdom
Czechoslovakia	Netherlands	U.S.S.R.
Finland	Norway	Yugoslavia
France	Philippines	

No member body expressed disapproval of the document.

# Shipbuilding — Filling connection for drinking water tanks on ships

iTeh STANDARD PREVIEW  
(standards.iteh.ai)

## 0 INTRODUCTION

The general rules for drinking water distribution systems fall within the competence of national port authorities and are outside the scope of this International Standard.

## 1 SCOPE

This International Standard specifies the drinking water connection for attachment of piping from another ship or from a land distribution system.

## 2 FIELD OF APPLICATION

This connection safeguards drinking water tanks from being filled with any other fluid and especially water unfit for human consumption. Additionally it safeguards the drinking water supply piping from contamination by any other liquids.

### NOTES

- 1 This International Standard may be applied to inland vessels if agreed between the users.
- 2 Users of this International Standard should note that while observing the requirements of the standard they should at the same time ensure compliance with such statutory requirements, rules and regulations as may be applicable to the individual ship concerned.

## 3 REFERENCE

ISO 1461, *Metallic coatings — Hot dip galvanized coating on fabricated ferrous products — Requirements.*

## 4 CONNECTION PRINCIPLE

The connection is carried out by means of flanges with a special five-hole drilling (see figure 1). The dimensions of these flanges are given in figures 2 and 3.

A flange shall be fitted to the ship's piping and a second one to the piping from the drinking water supply source.

The flange fitted to the ship's piping, having five studs secured by welding, shall be provided with a lockable cover (see figures 3 and 4).

A corrosion-resistant padlock shall be fitted to the bottom stud to prevent unauthorized access to the connection.

## 5 MATERIALS

The fitting shall be made of weldable steel with a tensile strength of at least 360 N/mm<sup>2</sup>. Corrosion protection shall be obtained by hot galvanizing in accordance with ISO 1461 or by any other coating which would not constitute a health hazard.

## 6 GASKET

A gasket of suitable material for drinking water systems shall be fitted to the ship flange.

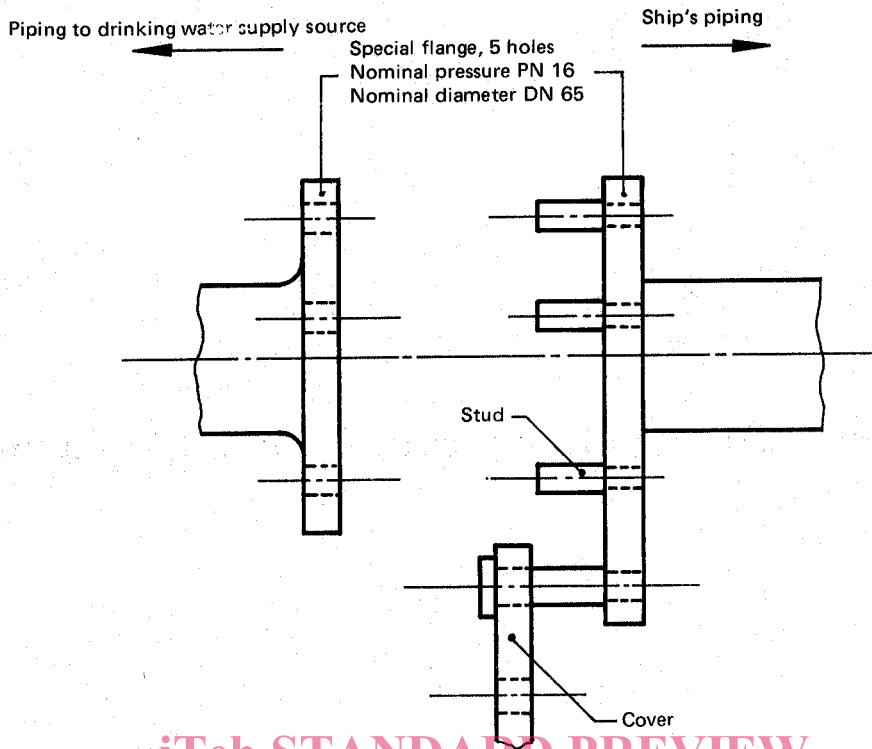

iTeh STANDARD PREVIEW  
(FIGURE 1 - Connection principle)  
(standards.iteh.ai)

ISO 5620:1978  
<https://standards.iteh.ai/catalog/standards/sist/1a37b916-4801-4cd7-ac9b-466758939537/iso-5620-1978>  
 Dimensions in millimetres

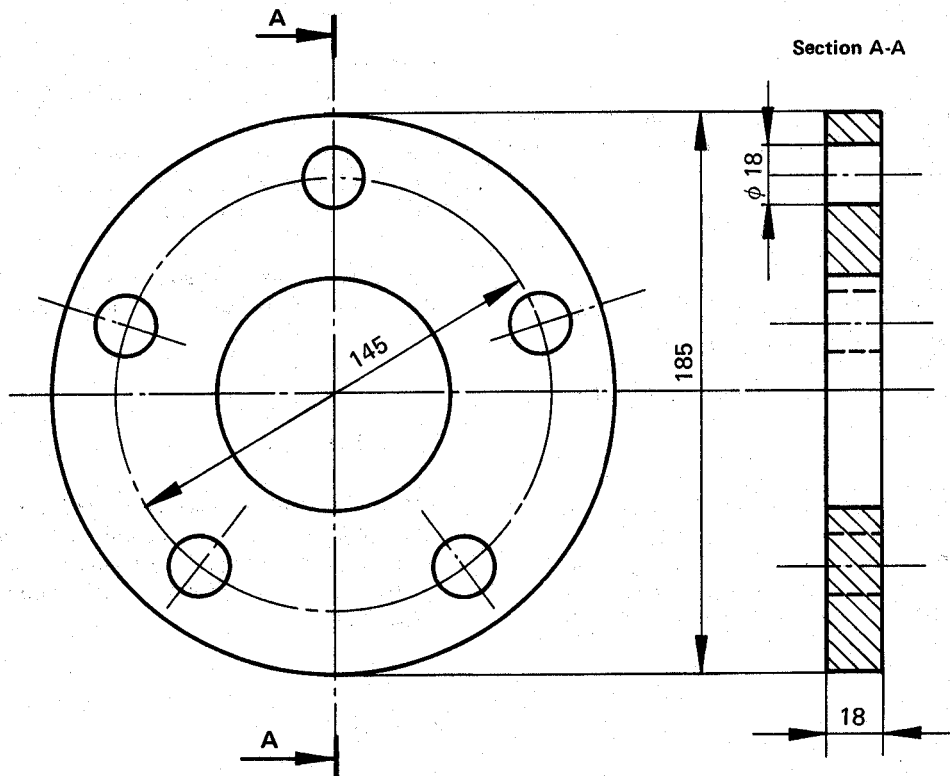
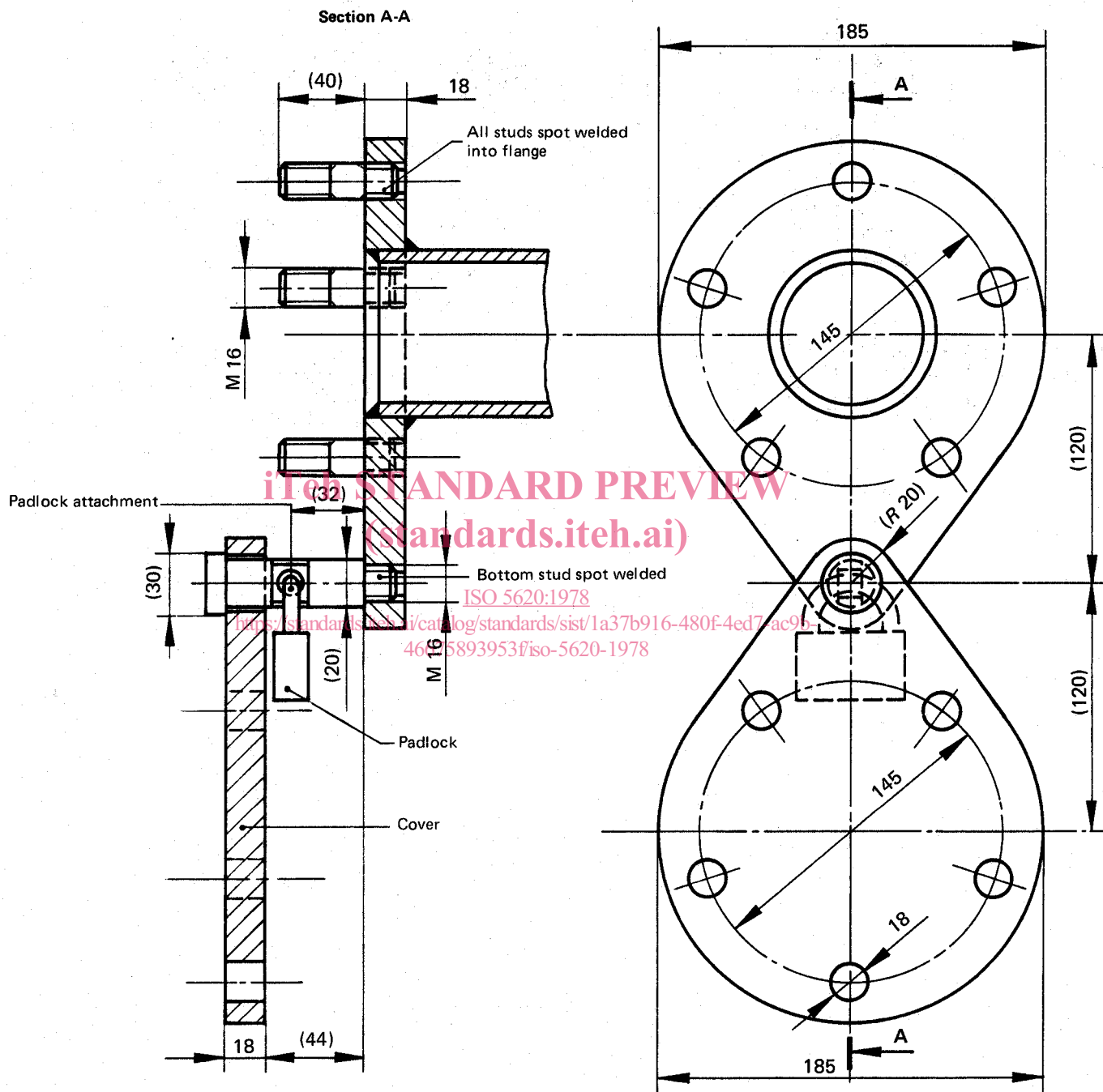

FIGURE 2 - Flange of piping to drinking water supply source

Dimensions in millimetres



NOTE — Dimensions in brackets are given for guidance only.

FIGURE 3 — Flange of ship's piping, with cover opened

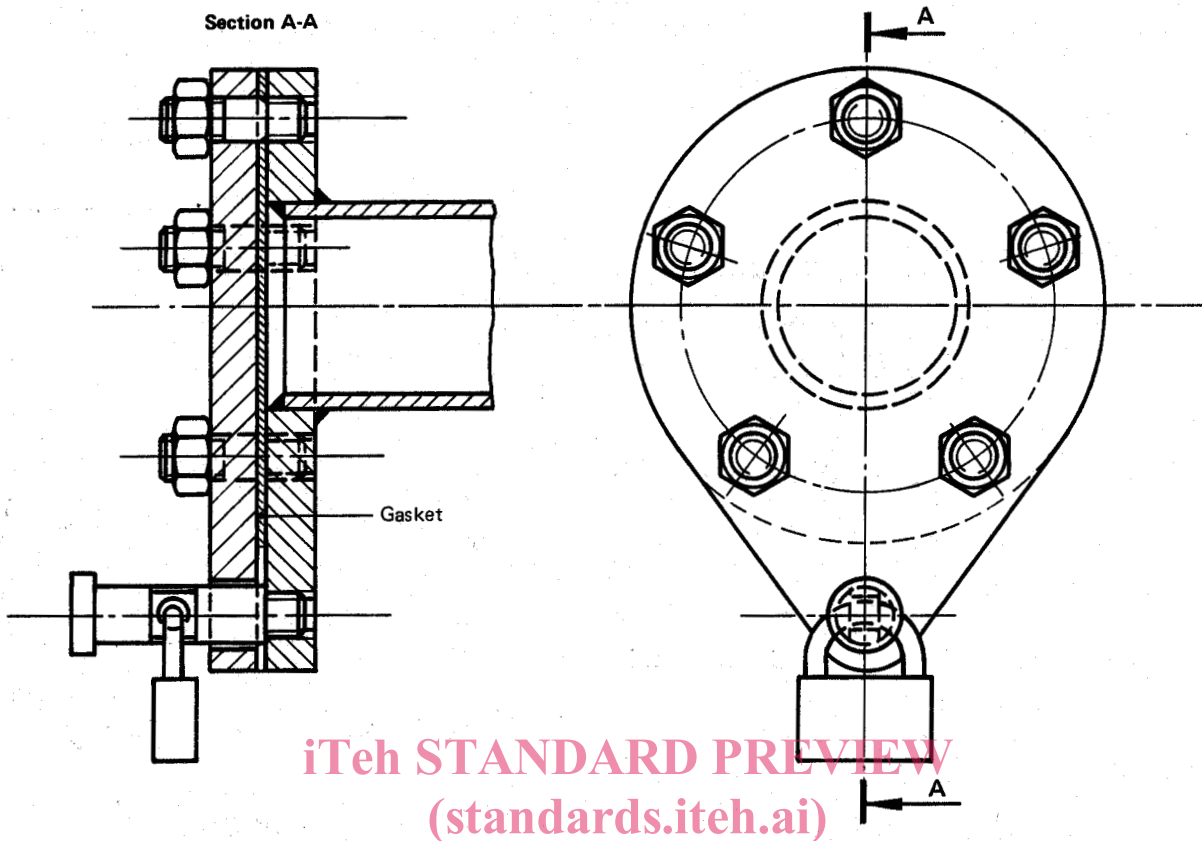

iTeh STANDARD PREVIEW  
(standards.iteh.ai)

ISO 5620-1978  
FIGURE 4 – Flange of ship's piping, with cover closed  
<https://standards.iteh.ai/catalog/standards/sist/1a37b916-480f-4ed7-ac9b-46675893953f/iso-5620-1978>

**iTeh STANDARD PREVIEW**  
**(standards.iteh.ai)**

ISO 5620:1978

<https://standards.iteh.ai/catalog/standards/sist/1a37b916-480f-4ed7-ac9b-46675893953f/iso-5620-1978>

**iTeh STANDARD PREVIEW**  
**(standards.iteh.ai)**

ISO 5620:1978

<https://standards.iteh.ai/catalog/standards/sist/1a37b916-480f-4ed7-ac9b-46675893953f/iso-5620-1978>