



Designation: **G187–18** G187 – 23

## Standard Test Method for Measurement of Soil Resistivity Using the Two-Electrode Soil Box Method<sup>1</sup>

This standard is issued under the fixed designation G187; the number immediately following the designation indicates the year of original adoption or, in the case of revision, the year of last revision. A number in parentheses indicates the year of last reappraisal. A superscript epsilon ( $\epsilon$ ) indicates an editorial change since the last revision or reappraisal.

### 1. Scope

1.1 This test method covers the equipment and procedures for the measurement of soil resistivity, for soil samples removed from the ground, for use in the assessment and control of corrosion of buried structures.

1.2 Procedures allow for this test method to be used in the field or in the laboratory.

1.3 The test method procedures are for the resistivity measurement of soil samples in the saturated condition and in the as-received condition.

1.4 The values stated in SI units are to be regarded as the standard. The values given in parentheses are for information only. Soil resistivity values are reported in ohm-centimeter.

1.5 *This standard does not purport to address all of the safety concerns, if any, associated with its use. It is the responsibility of the user of this standard to establish appropriate safety, health, and environmental practices and to determine the applicability of regulatory limitations prior to use.*

1.6 *This international standard was developed in accordance with internationally recognized principles on standardization established in the Decision on Principles for the Development of International Standards, Guides and Recommendations issued by the World Trade Organization Technical Barriers to Trade (TBT) Committee.*

### 2. Referenced Documents

#### 2.1 ASTM Standards:<sup>2</sup>

[D1193 Specification for Reagent Water](#)

[E691 Practice for Conducting an Interlaboratory Study to Determine the Precision of a Test Method](#)

[G57 Test Method for Measurement of Soil Resistivity Using the Wenner Four-Electrode Method](#)

[G193 Terminology and Acronyms Relating to Corrosion](#)

#### 2.2 UNS Standards:<sup>3</sup>

[UNS Designation S30400 & S30403](#)

[UNS Designation S31600 & S31603](#)

<sup>1</sup> This test method is under the jurisdiction of ASTM Committee G01 on Corrosion of Metals and is the direct responsibility of Subcommittee G01.10 on Corrosion in Soils.

Current edition approved May 1, 2018; Nov. 1, 2023. Published July 2018; December 2023. Originally approved in 2005. Last previous edition approved in 2012 as G187 – 12a; G187 – 18. DOI: 10.1520/G0187-18-10.1520/G0187-23.

<sup>2</sup> For referenced ASTM standards, visit the ASTM website, [www.astm.org](http://www.astm.org), or contact ASTM Customer Service at [service@astm.org](mailto:service@astm.org). For *Annual Book of ASTM Standards* volume information, refer to the standard's Document Summary page on the ASTM website.

<sup>3</sup> UNS (Unified Numbering System) was developed jointly by ASTM International and SAE International.

### 3. Terminology

#### 3.1 Definitions:

3.1.1 *conductivity, n*—A measure of the ability of a material to conduct an electrical charge (conductivity is the reciprocal of resistivity).

~~3.1.2 *soil resistivity, n*—The electrical resistance between opposite faces of a unit cube of material, typically expressed in ohm-meter, ohm-cm, or similar units; the reciprocal of conductivity.~~

3.1.2 *saturated soil, n*—soil whose entire soil porosity is filled with water.

3.1.3 *soil box factor, n*—A factor which is determined by a two-electrode soil box's internal dimensions (cross sectional area/distance between electrode plates). The soil box factor is multiplied by the measured resistance of a substance in the soil box to obtain that substance's resistivity.

3.1.4 *soil resistance meter, n*—An instrument capable of measuring soil resistance.

3.1.5 *soil resistivity, n*—The electrical resistance between opposite faces of a unit cube of material, typically expressed in ohm-meter, ohm-cm, or similar units; the reciprocal of conductivity.

3.1.6 *two-electrode soil box, n*—A non-conductive container of known internal dimensions with two end plate electrodes for measuring a substance's resistivity.

3.2 The terminology used herein, if not specifically defined otherwise, shall be in accordance with Terminology **G193**. Definitions provided herein and not given in Terminology **G193** are limited only to this standard.

### 4. Summary of Test Method

4.1 The two-electrode soil box method is predicated on measuring the resistance between two electrodes located on opposing faces of a soil box containing a saturated or as-received soil sample. That resistance is then converted to resistivity based on the soil box factor as discussed in Section 11.

### 5. Significance and Use<sup>4</sup>

5.1 The resistivity of the surrounding soil environment is a factor in the corrosion of underground structures. High resistivity soils are generally not as corrosive as low resistivity soils. The resistivity of the soil is one of many factors that influence the service life of a buried structure. Soil resistivity may affect the material selection and the location of a structure.<sup>5</sup>

5.2 Soil resistivity is of particular importance and interest in the corrosion process because it is basic in the analysis of corrosion problems and the design of corrective measures.

5.3 The test method is focused to provide an accurate, expeditious measurement of soil resistivity to assist in the determination of a soil's corrosive nature. Test Method **G57** emphasizes an *in situ* measurement commonly utilized in the design of a buried structures' corrosion control (cathodic protection systems' ground bed design, and so forth), but also includes information and procedures on a four-pin soil box method. The two-electrode soil box method is an accurate and more expeditious method than the four-pin soil box and often complements the four-pin, *in situ* soil resistivity method.

5.4 The saturated soil resistivity determined by this test method does not necessarily indicate the minimum soil resistivity.

<sup>4</sup> Method of Test for the Resistivity of Soils Material, Texas State Department of Highways and Public Transportation – Materials and Tests Division, Test Method Tex-129-E, November 1986.

<sup>5</sup> Method for Estimating the Service Life of Steel Culverts, California State Department of Transportation – Engineering Service Center, California Test 643, November 1999.

6. Apparatus

6.1 The equipment required for the measurement of the resistivity of soil samples, either in the field or in the laboratory, consists of a two-electrode soil box, a soil resistance meter, wiring to make the necessary connections and a soil extraction tool with straightedge. A two-electrode soil box, soil resistance meter and its electrical connections are shown in Fig. 1.

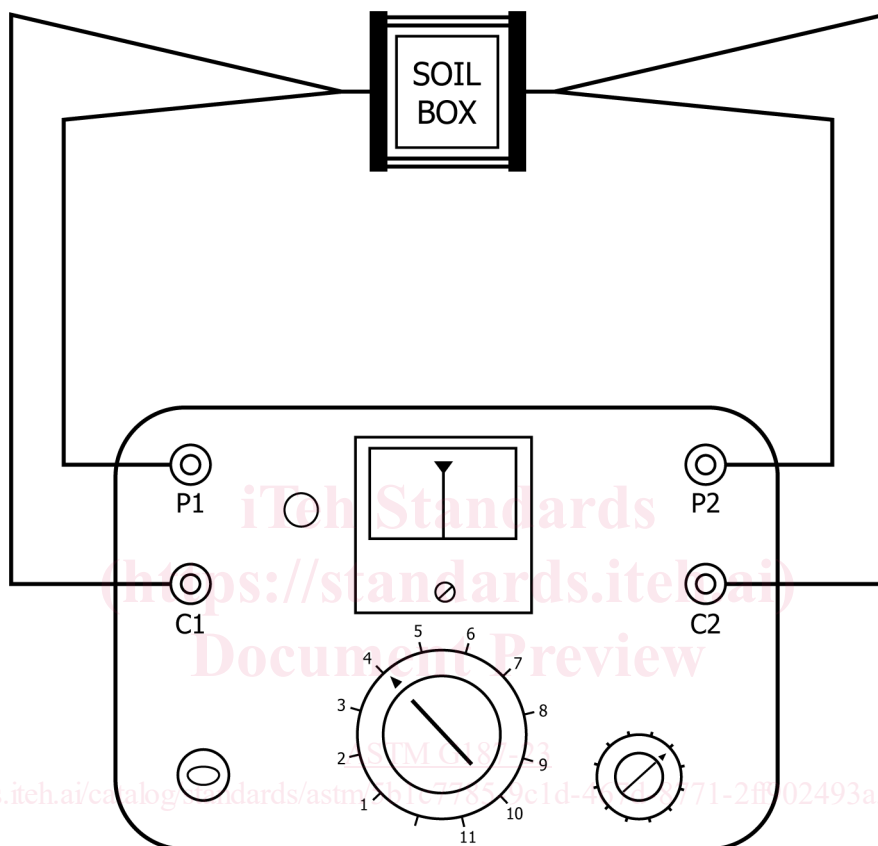

FIG. 1 Typical Connections for Use of Soil Box with Soil Resistance Meter

NOTE 1—The soil extraction tool should be non-metallic so as to avoid damage to the soil box during use. It should fit within the soil box to facilitate removal of the soil sample after completion of each test. It should be rigid enough to aid in compaction of the soil sample in the soil box, and it should have a straight edge to facilitate levelling of the soil sample after compaction. The soil extraction tool may be a commercially available utensil designed specifically for use with the soil box. In lieu of this, any suitable implement such as a plastic putty knife may be used.

6.2 *Two-Electrode Soil Box—Box*<sup>6</sup>—Two-electrode soil boxes can be constructed in various sizes provided the inside dimensions are known. Design and construction shall incorporate materials that are durable and machinable. The two end plate electrodes shall be constructed of a clean, polished corrosion-resistant metal or alloy (that is, UNS Designation type S30400/S30403 or UNS S31600/S31603 stainless steel) that will not form a heavy oxide film or otherwise add significant resistance. The body of the box

<sup>6</sup> The sole source of supply of the apparatus known to the committee at this time is VWR International, 1310 Goshen Parkway, West Chester, PA 19380, USA. If you are aware of alternative suppliers, please provide this information to ASTM International Headquarters. Your comments will receive careful consideration at a meeting of the responsible technical committee,<sup>1</sup> which you may attend.

shall be constructed of a material that is non-conductive and able to maintain its desired dimensions (polycarbonate plastics). The box shall be readily cleanable to avoid contamination by previous samples. See Fig. 2.

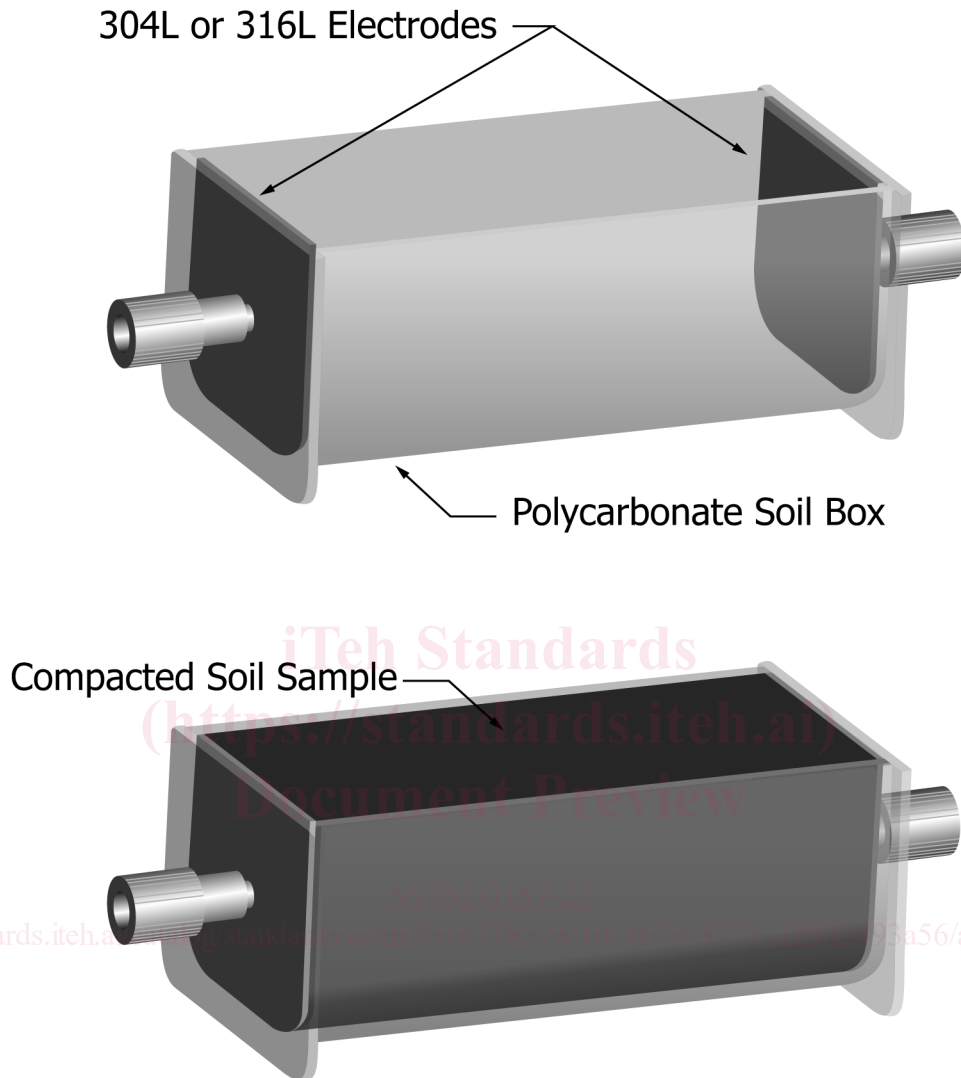

FIG. 2 Typical Two-Electrode Soil Box (Empty and Full)

**6.3 Soil Extraction Tool**—The soil extraction tool size and design will vary based on the size and design of the soil box. It should be non-metallic so as to avoid damage to the soil box during use, and it should fit snugly within the soil box to facilitate removal of the soil sample after completion of each test. It should be rigid enough to aid in compaction of the soil sample in the soil box, and it should have a straight edge to facilitate levelling of the soil sample after compaction. The soil extraction tool may be a commercially available utensil designed specifically for use with the soil box. In lieu of this, any suitable implement such as a plastic putty knife or custom shaped plastic tool may be used.

**6.4 Four Terminal Resistance Meter**—Commercially available four terminal soil resistance meters are commonly used for measuring soil resistivity. They offer convenience, ease of use, and repeatability. Soil resistance meters yield direct readings in ohms, which are multiplied by the appropriate factor for the specific two-electrode soil box. The meter utilized may limit the upper range of resistivity, which can be measured. In such cases, the resistivity should be reported as greater than the meter's upper limit.

**6.5 Wiring**—18 AWG to 22 AWG insulated stranded copper wire.