



Designation: **D6042–09 (Reapproved 2016) D6042 – 23**

Standard Test Method for Determination of Phenolic Antioxidants and Erucamide Slip Additives in Polypropylene Homopolymer Formulations Using Liquid Chromatography (LC) ¹

This standard is issued under the fixed designation D6042; the number immediately following the designation indicates the year of original adoption or, in the case of revision, the year of last revision. A number in parentheses indicates the year of last reapproval. A superscript epsilon (ϵ) indicates an editorial change since the last revision or reapproval.

1. Scope Scope*

1.1 This test method covers a liquid-chromatographic procedure for the separation of some additives currently used in polypropylene. These additives are extracted with a cyclohexane:methylene chloride mixture using either reflux or ultrasonic bath prior to liquid-chromatographic separation. The ultraviolet absorbance (200 nm) of the compound(s) is measured, and quantitation is performed using the internal standard method.

1.2 The values stated in SI units are to be regarded as standard. No other units of measurement are included in this standard.

1.3 *This standard does not purport to address all of the safety concerns, if any, associated with its use. It is the responsibility of the user of this standard to establish appropriate safety and health, safety, health, and environmental practices and determine the applicability of regulatory limitations prior to use. Specific precautionary statements are given in Section 9.*

NOTE 1—There is no known ISO equivalent to this test method.

1.4 *This international standard was developed in accordance with internationally recognized principles on standardization established in the Decision on Principles for the Development of International Standards, Guides and Recommendations issued by the World Trade Organization Technical Barriers to Trade (TBT) Committee.*

2. Referenced Documents

2.1 ASTM Standards:²

[D883 Terminology Relating to Plastics](#)

[D1600 Terminology for Abbreviated Terms Relating to Plastics](#)

[E131 Terminology Relating to Molecular Spectroscopy](#)

[E456 Terminology Relating to Quality and Statistics](#)

[E691 Practice for Conducting an Interlaboratory Study to Determine the Precision of a Test Method](#)

[IEEE/ASTM SI-10 Practice for Use of the International System of Units \(SI\) \(the Modernized Metric System\)](#)

3. Terminology

3.1 For definitions of plastic terms used in this test method, see Terminologies [D883](#) and [D1600](#).

¹ This test method is under the jurisdiction of ASTM Committee [D20](#) on Plastics and is the direct responsibility of Subcommittee [D20.70](#) on Analytical Methods ([D20.70.02](#)).

Current edition approved Sept. 1, 2016/Nov. 1, 2023. Published September 2016/December 2023. Originally approved in 1996. Last previous edition approved in 2009/2016 as [D6042–09](#)/[D6042 - 09](#) (2016). DOI: [10.1520/D6042-09R16](#)/[10.1520/D6042-23](#).

² For referenced ASTM standards, visit the ASTM website, [www.astm.org](#), or contact ASTM Customer Service at [service@astm.org](#). For *Annual Book of ASTM Standards* volume information, refer to the standard's Document Summary page on the ASTM website.

*A Summary of Changes section appears at the end of this standard

3.2 For the units, symbols, and abbreviations used in this test method, refer to Terminology **E131** or Practice **IEEE/ASTM SI-10**.

3.3 Abbreviations:

3.3.1 *LC*—liquid chromatography.

3.3.2 *PP*—polypropylene.

3.4 Trade Names:

3.4 *Vitamin E*— α -Tocopherol, or 3,4-dihydro-2,5,7,8-tetramethyl-2-(4,8,12-trimethyltridecyl)-2H-1-benzopyran-6-ol.

3.5 *Irgafos 168*—Tris(2,4 di-tert-butylphenyl) phosphite.

3.6 *Irganox 3114*—Tris(3,5-di-t-butyl-4-hydroxybenzyl) isocyanurate.

3.7 *Kemamide-E*—cis-13-docosenamide or erucamide.

3.8 *Irganox 1010*—tetrakis[methylene(3,5-di-t-butyl-4-hydroxy hydrocinnamate)]methane.

3.9 *Irganox 1076*—octadecyl-3,5-di-t-butyl-4-hydroxy hydrocinnamate.

3.10 *Tinuvin P*—2(2'-hydroxy-5'-methyl phenyl)benzotriazole.

4. Summary of Test Method

4.1 The PP sample is ground to a 20-mesh particle size (850 microns) and extracted by refluxing with a mixture of 75:25 methylene chloride:cyclohexane or placing in an ultrasonic bath with the same mixture.

4.2 The solvent extract is examined by liquid chromatography.

4.3 Additive concentrations are determined relative to an internal standard (contained in the solvent) using reverse-phase chromatography (C-18 column) with ultraviolet (UV) detection at 200 nm.

5. Significance and Use

5.1 Separation and identification of stabilizers used in the manufacture of polypropylene is necessary in order to correlate performance properties with polymer composition. This test method provides a means to determine erucamide slip, Vitamin E, Irgafos 168, Irganox 3114, Irganox 1010, and Irganox 1076 levels in polypropylene samples. This test method is also applicable for the determination of other antioxidants, such as Ultrinox 626, Ethanox 330, Santanox R, and BHT, but the applicability of this test method has not been investigated for these antioxidants.

5.2 The additive-extraction procedure is made effective by the insolubility of the polymer sample in solvents generally used for liquid chromatographic analysis.

5.3 Under optimum conditions, the lowest level of detection for a phenolic antioxidant is approximately 2 ppm.

NOTE 2—Other methods that have been used successfully to remove additives from the plastics matrix include thin film, microwave, ultrasonic, and supercritical fluid extractions. Other methods have been used successfully to separate additives including SFC and capillary GC.

5.4 Irgafos 168 is a phosphite antioxidant. Phosphites are known to undergo both oxidation and hydrolysis reactions. Less Irgafos 168 will be determined in the polymer when oxidation occurs during processing. The HPLC separation is capable of separating

the phosphite, phosphate (oxidation product), and hydrolysis product and quantify them if standards are obtained. No significant breakdown of the phosphite antioxidant has been seen due to either extraction technique or the separation presented in this standard.

6. Interferences

6.1 Any material eluting at or near the same retention time as the additive has been known to cause erroneous results. Examining a polymer-solvent-extract solution containing no internal standard is recommended to minimize the possibility of interferences.

6.2 Solvent impurity is a major source of interference. It is a good practice to examine the solvents prior to use by injecting a sample of solvent on the HPLC system and analyzing as in Section 10.

6.3 The oxidation product of Irgafos 168 sometimes overlaps with other additives with retention times of components that elute between Irganox 1010 and Irgafos 168. In these cases, run known standards to ensure that components of interest do not coelute with the oxidation product of Irgafos 168.

7. Apparatus

7.1 *Liquid Chromatograph*, equipped with a sample injector, variable-wavelength ultraviolet detector, heated column, and gradient-elution capabilities.

7.2 *Chromatographic Column*, RP-18, 5- μ m particle size, 15 cm by 4.6 mm.

NOTE 3—A Zorbax RX C-18 Column by Agilent was used for this test method. The gradient described in 10.1 provides complete separation of antioxidants using this C-18 column.

7.3 *Computer System or Integrator*, coupled with the chromatograph is recommended to measure peak area.

7.4 *Wiley Mill*, equipped with a 20-mesh screen and water-cooled jacket to prevent thermodegradation of antioxidants.

7.5 *Recorder*, mV scale dependent upon the output of the detector.

7.6 *Reflux Extraction Apparatus*, consisting of a condenser (24/40 ground-glass joint), a flat bottom 125 mL flask having a 24/40 ground-glass joint, and a hot plate with magnetic stirrer (see Fig. 1).

7.7 *Ultrasonic Bath Apparatus*, consisting of the ultrasonic bath, a flat bottom 125-mL flask having a 24/40 ground-glass joint, and a 24/40 ground-glass stopper.

7.8 *Filter System (Teflon)*³ for nonaqueous solutions (pore size of 0.45 μ m or less) equipped with a glass 5-cm³ syringe.

NOTE 4—The filter shall give no ghost peak with blank solvent.

7.9 *Analytical Balance*, capable of weighing to ± 0.0001 g.

8. Reagents and Materials

8.1 *Tinuvin-P*, 2(2' hydroxy-5'-methyl phenyl) benzotriazole.

8.2 *Methylene Chloride*, HPLC grade, spectral quality or chromatography quality reagent.

8.3 *Cyclohexane*, HPLC grade, spectral quality or chromatography quality reagent.

³ Registered trademark of DuPont.

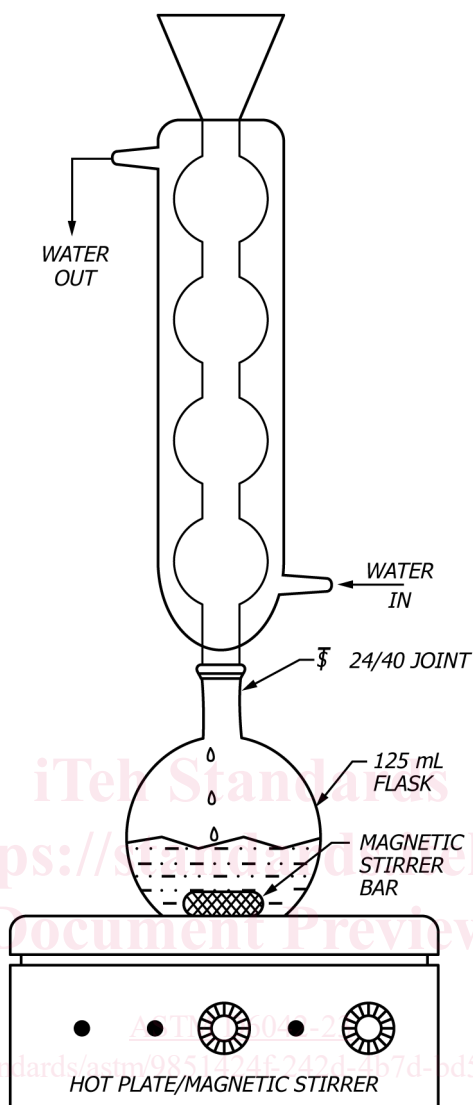

FIG. 1 Sample Extraction

8.4 75:25 Methylene Chloride:Cyclohexane T-P, mixture with 51.8 mg/L Tinuvin-P added as an internal standard.

8.5 Water, HPLC or UV quality reagent, degassed by sparging with high purity helium or by filtration under vacuum.

8.6 Acetonitrile, HPLC, spectral quality or chromatography quality reagent (a reagent whose UV cut-off is about 190 nm).

8.7 Isopropanol, HPLC, spectral quality or chromatography quality reagent.

9. Safety and Precautions

9.1 Methylene chloride and cyclohexane are flammable and toxic. Perform this extraction procedure in a fume hood.

10. Preparation of Liquid Chromatograph

10.1 Set the chromatograph to operate at the following conditions (see Fig. 2 for an example chromatogram):

10.1.1 Initial Mobile Phase Condition—75 % acetonitrile: 25 % water or whatever is appropriate for column used in order to retain Tinuvin P longer than solvent breakthrough.