



Designation: E2581 – 14 (Reapproved 2023)

Standard Practice for Shearography of Polymer Matrix Composites and Sandwich Core Materials in Aerospace Applications¹

This standard is issued under the fixed designation E2581; the number immediately following the designation indicates the year of original adoption or, in the case of revision, the year of last revision. A number in parentheses indicates the year of last reapproval. A superscript epsilon (ϵ) indicates an editorial change since the last revision or reapproval.

This standard has been approved for use by agencies of the U.S. Department of Defense.

1. Scope

1.1 This practice describes procedures for shearography of polymer matrix composites and sandwich core materials made entirely or in part from fiber-reinforced polymer matrix composites. The composite materials under consideration typically contain continuous high modulus (greater than 20 GPa (3×10^6 psi)) fibers, but may also contain discontinuous fiber, fabric, or particulate reinforcement.

1.2 This practice describes established shearography procedures that are currently used by industry and federal agencies that have demonstrated utility in quality assurance of polymer matrix composites and sandwich core materials during product process design and optimization, manufacturing process control, after manufacture inspection, and in service inspection.

1.3 This practice has utility for testing of polymer matrix composites and sandwich core materials containing but not limited to bismaleimide, epoxy, phenolic, poly(amideimide), polybenzimidazole, polyester (thermosetting and thermoplastic), poly(ether ether ketone), poly(ether imide), polyimide (thermosetting and thermoplastic), poly(phenylene sulfide), or polysulfone matrices; and alumina, aramid, boron, carbon, glass, quartz, or silicon carbide fibers. Typical as-fabricated geometries include uniaxial, cross-ply and angle-ply laminates; as well as honeycomb and foam core sandwich materials and structures.

1.4 This practice does not specify accept-reject criteria and is not intended to be used as a means for approving polymer matrix composites or sandwich core materials for service.

1.5 To ensure proper use of the referenced standards, there are recognized nondestructive testing (NDT) specialists that are certified according to industry and company NDT specifications. It is recommended that an NDT specialist be a part of

any composite component design, quality assurance, in-service maintenance, or damage examination activity.

1.6 *This standard does not purport to address all of the safety concerns, if any, associated with its use. It is the responsibility of the user of this standard to establish appropriate safety, health, and environmental practices and determine the applicability of regulatory limitations prior to use.*

1.7 *This international standard was developed in accordance with internationally recognized principles on standardization established in the Decision on Principles for the Development of International Standards, Guides and Recommendations issued by the World Trade Organization Technical Barriers to Trade (TBT) Committee.*

2. Referenced Documents

2.1 ASTM Standards:²

[C274 Terminology of Structural Sandwich Constructions \(Withdrawn 2016\)³](#)

[D3878 Terminology for Composite Materials](#)

[D5687/D5687M Guide for Preparation of Flat Composite Panels with Processing Guidelines for Specimen Preparation](#)

[E543 Specification for Agencies Performing Nondestructive Testing](#)

[E1309 Guide for Identification of Fiber-Reinforced Polymer-Matrix Composite Materials in Databases \(Withdrawn 2015\)³](#)

[E1316 Terminology for Nondestructive Examinations](#)

[E1434 Guide for Recording Mechanical Test Data of Fiber-Reinforced Composite Materials in Databases \(Withdrawn 2015\)³](#)

[E1471 Guide for Identification of Fibers, Fillers, and Core Materials in Computerized Material Property Databases \(Withdrawn 2015\)³](#)

¹ This practice is under the jurisdiction of ASTM Committee E07 on Nondestructive Testing and is the direct responsibility of Subcommittee E07.10 on Specialized NDT Methods.

Current edition approved Dec. 1, 2023. Published December 2023. Originally approved in 2007. Last previous edition approved in 2019 as E2581 – 14 (2019). DOI: 10.1520/E2581-14R23.

² For referenced ASTM standards, visit the ASTM website, www.astm.org, or contact ASTM Customer Service at service@astm.org. For *Annual Book of ASTM Standards* volume information, refer to the standard's Document Summary page on the ASTM website.

³ The last approved version of this historical standard is referenced on www.astm.org.

E2533 Guide for Nondestructive Examination of Polymer Matrix Composites Used in Aerospace Applications

E2982 Guide for Nondestructive Examination of Thin-Walled Metallic Liners in Filament-Wound Pressure Vessels Used in Aerospace Applications

F1364 Practice for Use of a Calibration Device to Demonstrate the Inspection Capability of an Interferometric Laser Imaging Nondestructive Tire Inspection System

2.2 *ASNT Standards*:⁴

SNT-TC-1A Recommended Practice for Personnel Qualification and Certification in Nondestructive Testing

ANSI/ASNT CP-189 Standard for Qualification and Certification of Nondestructive Testing Personnel

2.3 *AIA Document*:⁵

NAS-410 Certification and Qualification of Nondestructive Test Personnel

2.4 *BSI Document*:⁶

EN 60825-1 Safety of Laser Products - Part 1: Equipment Classification, Requirements, and User's Guide

2.5 *LIA Document*:⁷

ANSI Z136.1-2000 Safe Use of Lasers

2.6 *Federal Standards*:⁸

21 CFR 1040.10 Laser products

21 CFR 1040.11 Specific purpose laser products

29 CFR 1910.95 Occupational Noise Exposure

3. Terminology

3.1 *Definitions*—Definition of terms related to structural sandwich constructions, NDT, and composites appearing in Terminologies **C274**, **E1316**, and **D3878**, respectively, shall apply to the terms used in this standard.

3.2 *Definitions of Terms Specific to This Standard*:

3.2.1 *aerospace*—any component that will be installed on a system that flies.

3.2.2 *beam splitter*—an optical element capable of splitting a single beam of coherent laser light into two beams. Beam splitters are key elements of Michelson Type Image Shearing Interferometers.

3.2.3 *cognizant engineering organization*—the company, agency, or other authority responsible for the design or after delivery, end use of the system or component for which laser holographic or laser shearographic examination is required; in addition to design personnel, this may include personnel from material and process engineering, stress analysis, NDT, or quality groups and others as appropriate.

⁴ Available from American Society for Nondestructive Testing (ASNT), P.O. Box 28518, 1711 Arlingate Ln., Columbus, OH 43228-0518, <http://www.asnt.org>.

⁵ Available from Aerospace Industries Association of America, Inc. (AIA), 1000 Wilson Blvd., Suite 1700, Arlington, VA 22209-3928, <http://www.aia-aerospace.org>.

⁶ Available from British Standards Institution (BSI), 389 Chiswick High Rd., London W4 4AL, U.K., <http://www.bsigroup.com>.

⁷ Available from the Laser Institute of America, 13501 Integrity Drive, Suite 128, Orlando FL 32826.

⁸ Available from U.S. Government Printing Office Superintendent of Documents, 732 N. Capitol St., NW, Mail Stop: SDE, Washington, DC 20401, <http://www.access.gpo.gov>.

3.2.4 *coherent light source*—a light source that converts electrical energy to a monochromatic beam of light having uniform phase over a minimum specified length known as the coherent length.

3.2.5 *component*—the part(s) or element(s) of a system described, assembled, or processed to the extent specified by the drawing.

3.2.6 *composite material*—see Terminology **D3878**.

3.2.7 *composite component*—a finished part containing composite material(s) that is in its end use application configuration and which has undergone processing, fabrication, and assembly to the extent specified by the drawing, purchase order, or contract.

3.2.8 *core crush*—a collapse, distortion, or compression of core material in a sandwich structure.

3.2.9 *core separation*—a partial or complete breaking of honeycomb core node bonds.

3.2.10 *disbond, unbond*—see Terminology **D3878**.

3.2.11 *de-correlation*—loss of shearography phase data caused by test part deformation exceeding the resolution of the shearing interferometer or motion occurs between the test object and shearing interferometer during data acquisition.

3.2.12 *delamination*—see Terminology **D3878**.

3.2.13 *displacement derivatives ($\partial w/\partial x$)*—rate of spatial displacement change, where w is the surface displacement and x is the surface coordinates.

3.2.14 *fringe pattern*—a set of lines in a subtraction or wrapped phase shearogram that represents the locus of equal out-of-plane deformation derivative.

3.2.15 *impact damage*—fracturing of epoxy matrix, fiber breakage, inter-laminar delamination of monolithic composites, composite sandwich structure face sheets due to impact, characterized by visible dimple surface compression, or fiber breakage caused by impact strike and non-visible subsurface matrix cracking and delamination.

3.2.16 *inclusion*—foreign objects or material including but not limited to particles, chips, backing films, razor blades, or tools of varying sizes which are inadvertently left in a composite lay-up.

3.2.17 *indication*—the observation or evidence of a condition resulting from the shearographic examination that requires interpretation to determine its significance, characterized by dimensions, area, s/n ratio, or other quantitative measurement.

3.2.18 *laser shearography inspection, shearography inspection, shearography*—inspection method utilizing interferometric imaging of deformation derivatives compared between different strain states and designed to reveal non-homogeneities, material changes and structural defects throughout the volume of the material.

3.2.19 *out-of-plane displacement*—the local deformation of a test part, normal to the surface, caused by the application of an engineered force acting on a non-homogeneity or defect in a composite material.

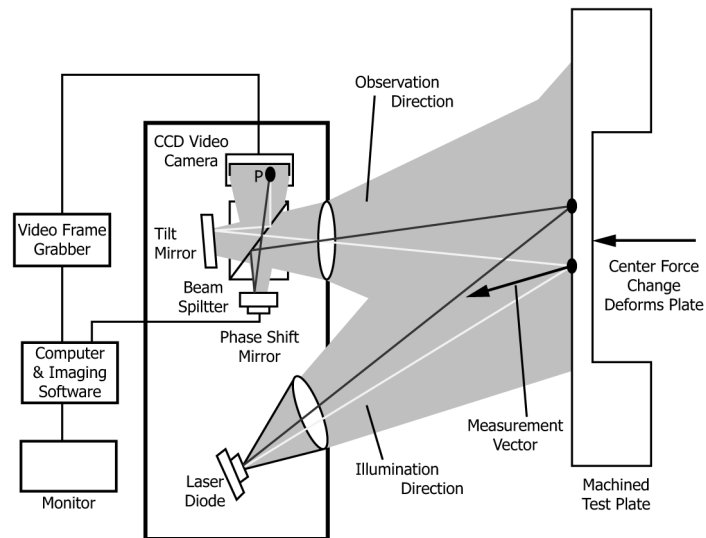

FIG. 1 Schematic diagram of a Michelson type shearing interferometer shown with a shearography calibration device consisting of a metal plate with a machined flat bottomed hole creating a deformable plate with a precision mechanical mechanism for loading at the center point.

3.2.20 *polymer matrix composite*—any fiber-reinforced composite lay-up consisting of laminae (plies) with one or more orientations with respect to some reference direction that are consolidated by press, vacuum bagging, or autoclave to yield an engineered part article or structure.

3.2.21 *porosity*—condition of trapped pockets of air, gas, or void within solid materials, usually expressed as a percentage of the total nonsolid volume (solid + nonsolid) of a unit quantity of material.

3.2.22 *sandwich core material*—an engineered part, article, or structure made up of two or more sheets of composite laminate, metal, or other material designed to support in-plane tensile or compressive loads, separated by and bonded to inner core(s) material(s) designed to support normal compressive and tensile loads such as metal or composite honeycomb, open and closed cell foam, wave formed material, bonded composite tubes, or naturally occurring material such as end grain balsa wood.

3.2.23 *scan plan*—a designed sequence of steps for positioning and adjusting a shearography camera to accomplish a desired inspection. Scan plans shall include camera field of view, percentage of image overlap, position sequences for each area to be tested, test number, and location in a coordinate system appropriate for test object geometry and access.

3.2.24 *shearogram*—the resulting image from the complex arithmetic combination of interferograms made with an image shearing interferometer and presented for interpretation in various image processing algorithms including wrapped phase maps (static or real-time), unwrapped phase maps, integrated, Doppler shift map.

3.2.25 *shearography camera, shear camera*—an image shearing interferometer used for shearography nondestructive testing, usually including features for adjustment of focus, iris, zoom, shear vector, and projection and adjustment of coherent light onto the test object area to be inspected.

3.2.26 *shear vector*—the separation vector between two identical images of the target in the output of an image shearing interferometer. The Shear vector is expressed in degrees of angle from the X axis, with a maximum of 90°, with + being in the positive Y direction and – in the negative Y direction. The shear distance between identical points in the two sheared images expressed in inches or mm. (See Fig. 2 shear vector angle convention).

3.2.27 *stressing device*—the means to apply a measurable and repeatable engineered stress to the test object during shearography inspection. The applied stress may be in the form of a partial vacuum, pressure, heat, vibration, magnetic field, electric field, microwave, or mechanical load. Also referred to as excitation or excitation method.

3.2.28 *void*—an empty, unoccupied space in laminate. Voids are associated with bridging and resin starved areas.

4. Summary of Practice

4.1 Shearography nondestructive inspection refers to the use of an image shearing interferometer to image local out-of-plane deformation derivatives on the test part surface in response to a change in the applied engineered load. Shearography images tend to show only the local deformation on the target surface due to the presence of a surface or subsurface flaw, delaminations, core damage, or core splice joint separations, as well as impact damage.

4.2 Typical applied loads to the test part are dependant on the test part material reaction to the induced load. The optimum load type and magnitude depend on the flaw type and flaw depth and are best determined before serial testing by making trial measurements. Care is taken to ensure that the magnitude of the applied load is acceptably below the damage threshold of a given test article. The applied load can be any of the

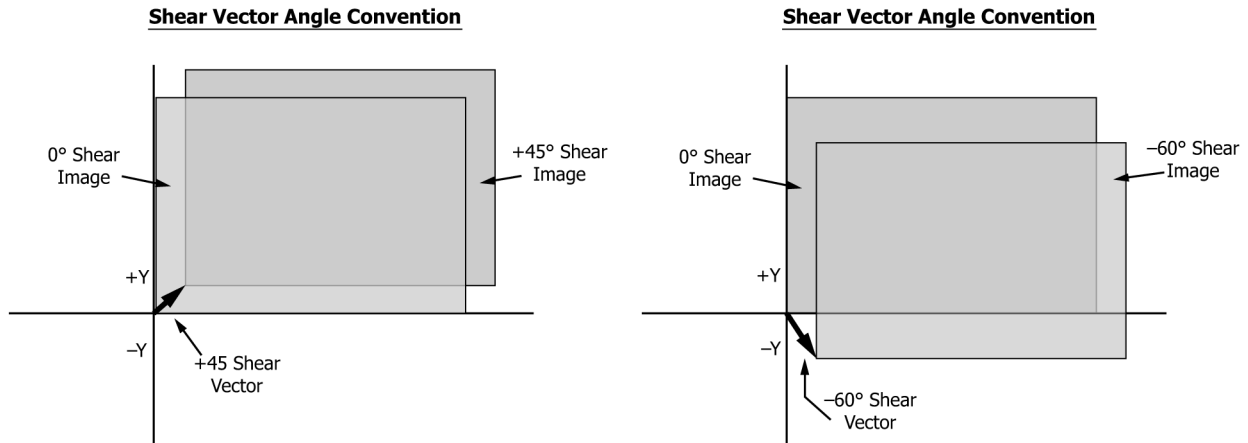

FIG. 2 Shear vector angle convention: Starting with the shear camera adjusted for a 0° shear condition, the sheared image is moved to the right (+X) or up/down, never adjusted in the direction of -X. For a +45° shear vector, the image is moved in the +X and +Y direction. For 60° shear vector, the image is adjusted in the +X and -Y directions. The convention allows determination of deformation direction from the unwrapped phase map.

following: heat, mechanical vibration, acoustic vibration, pressure and vacuum, electric fields, magnetic fields, microwave, or mechanical load.

4.3 Shearography NDT systems use a common path Michelson, birefringent, or beam splitter type shearing interferometer for imaging defects. Some of the most current technology shearography cameras often use a Michelson type interferometer, Fig. 1, with phase stepping capability. The shearography NDT procedure consists of illuminating a test article with fixed frequency laser light before and after a small proof load is applied. A mirror (the tilt mirror), or other optical device is precisely adjusted to induce an offset, or sheared image, of the test article with respect to a second image of the part. The amount of image shear is a vector quantity with an associated direction, angle, and distance (see Fig. 2). The shear vector, among other factors, determines the sensitivity of the interferometer to surface displacement derivatives, $\partial w / \partial x$. The two sheared images of the test image are focused onto the CCD camera. Light from pairs of points in each sheared image interfere with each other, causing interference at every paired

point across the field of view. A mirror in the Michelson interferometer may be phase shifted using a piezoelectric device and the sequential interferograms combined to create a phase map of the test object (see Fig. 4). Further processing using any number of unwrapping algorithms may be used to generate fringe free images of local surface deformation derivatives (see Fig. 5). Each video frame, or interferogram, comprises the complex addition of the two sheared images and can be subtracted from a stored reference image in real time, processed as a dynamic real time phase map or as a static image. Stressed test parts will show out-of-plane deformation (strain concentration) near flaws that is significantly greater than the out-of-plane deformation produced in flaw-free areas. These flaw areas are indicated by the presence of indications in phase maps and unwrapped phase maps. The unwrapped shearography image reveals direction of the test object deforming, either towards or away from the camera. This information may be used to discriminate between repairs, which are stiffer, and damage to aerospace sandwich panels.



FIG. 3 A shearography camera calibration device consists of a means to apply a known deformation to an aluminum flat plate. The flat surface deformation is imaged. This device allows verification of the shearography camera operation, laser stability, and the minimum coherence length.



FIG. 4 A phase map shearogram with horizontal shear vector yields a fringe pattern showing the first derivative of the out-of-plane deformation, $\partial w / \partial x$. Using an unwrapping algorithm, the image at right shows the positive (white) and negative (black) slope change.

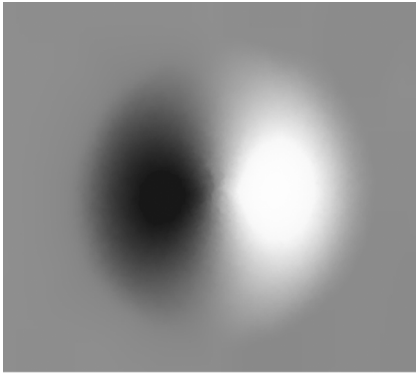

FIG. 5 An unwrapped phase map plots the test part surface deformation derivative without fringes.

4.4 Advantages and Applications—Shearography NDT is full field inspection method and specified area or parts can be inspected in a very short period of time. A sample size of 30.5 cm by 30.5 cm (12 in. by 12 in.) area might take several minutes to set up, then just a few seconds to apply to selected stress technique, collect and processing of the data. Throughputs range from $4.6 \text{ m}^2/\text{h}^{-1}$ to $46 \text{ m}^2/\text{h}^{-1}$ ($50 \text{ ft}^2/\text{h}^{-1}$ to $500 \text{ ft}^2/\text{h}^{-1}$) depending on the degree of automation, compared to $0.93 \text{ m}^2/\text{h}^{-1}$ ($10 \text{ ft}^2/\text{h}^{-1}$) throughput typical of Ultrasonic Testing (UT) C-Scan, depending on scan increment step size. Shearography inspection is non-contact, non-contaminating and does not require couplant or submersion. For production systems, shearography camera is typically located from 0.6 m to 1.8 m (2 ft to 6 ft) from inspection area and will not contact the inspection part. However, the applied loading method may require contact such as a vacuum window placed on the part or a transducer attached to the part for a mechanical stress of the part. Portable shearography systems for on-vehicle inspection are designed to vacuum attach to vehicle surfaces. Care must be taken to ensure no damage to very thin composite face sheets will be caused by such contact.

4.4.1 Inspection results can be kept as a permanent record and available for future evaluation and presentation. With some software, the data can be stored as a JPG, TIF, or other image format, and the raw data is stored and can be processed and evaluated at any time. Shearography systems utilize tools such as video calipers to allow for rapid defect sizing and area measurement.

4.5 Limitations and Interferences—The laser light used in shearography inspection is not a penetrating radiation. Shearography images subsurface flaws indirectly causing surface deformations above the flaw, in the range from 1 nm to 500 microns, which are detected by the shearography camera. These deformations are detected by the shearography camera. Shearography therefore is less sensitive to defects as the defect depth increases. Shearography is applicable to non-brittle materials, where critical flaw size is approximately smaller than the detectable limit. Shearography may not be applicable to materials with very high rigid strength, low or negative coefficient of thermal expansion, or thick face sheet thicknesses.

4.5.1 Ambient Light—Ambient light may overpower the low laser power density diffusely reflected from the test part,

degrading the shearography data. Most portable equipment includes features to allow testing in full daylight. Production shearography systems operate in test cells or away from high intensity ambient lighting.

4.5.2 Test Part Color and Reflectivity—Shearography requires imaging diffuse laser light reflected from the test part surface to create a full field image. The optimal surface is flat white. The worst condition for shearography inspection is a spherical or convoluted, gloss black test part. The glare from a spherical or convoluted surface and the specular reflection from the gloss surface create an extreme intensity distribution that degrades the shearography data. In these worst cases, coatings such as dye-penetrant developer may be applied to reduce glare and increase reflectivity.

4.5.3 Ambient Vibration or Test Part Motion—Ambient vibration or motion can degrade shearography image quality or prevent any useful image from being obtained. Usually vibration or part motion is predominately in one direction. Rotating the shear vector can reduce sensitivity in the direction motion is more prominent. Shimming the test piece and checking for part or camera movement can help eliminate the detrimental effects of motion.

5. Significance and Use

5.1 Shearography is commonly used during product process design and optimization, process control, after manufacture inspection, and in service inspection, and can be used to measure static and dynamic axial (tensile and compressive) strain, as well as shearing, Poisson, bending, and torsional strains. The general types of defects detected by shearography include delamination, deformation under load, disbond/unbond, microcracks, and thickness variation.

5.2 Additional information is given in Guide [E2533](#) about the advantages and limitations of the shearography technique, use of related ASTM documents, specimen geometry and size considerations, calibration and standardization, and physical reference standards.

5.3 For procedures for shearography of filament-wound pressure vessels, otherwise known as composite overwrapped pressure vessels, consult Guide [E2982](#).

5.4 Factors that influence shearography and therefore shall be reported include but are not limited to the following: laminate (matrix and fiber) material, lay-up geometry, fiber volume fraction (flat panels); facing material, core material, facing stack sequence, core geometry (cell size); core density, facing void content, and facing volume percent reinforcement (sandwich core materials); processing and fabrication methods, overall thickness, specimen alignment, specimen conditioning, specimen geometry, and test environment (flat panels and sandwich core materials). Shearography has been used with excellent results for composite and metal face sheet sandwich panels with both honeycomb and foam cores, solid monolithic composite laminates, foam cryogenic fuel tank insulation, bonded cork insulation, aircraft tires, elastomeric and plastic coatings. Frequently, defects at multiple and far side bond lines can be detected.

6. Equipment and Materials

6.1 The general shearography apparatus is shown schematically in Fig. 1, and shall include the following:

6.1.1 *Laser Shearography Camera*—The shearography camera shall have demonstrated the ability to detect the maximum allowable defect size and depth in similar material and structure as will be inspected and sufficient laser power to illuminate the test part. Shear cameras are available with both fixed, rotatable or fully, or adjustable shear vector.

6.1.2 *Camera Control and Calibration Device*—This device consists of controls to manipulate the camera and laser during the evaluation process. The first control allows for camera motion in the vertical (tilt) and horizontal (pan) planes. The second control permits adjustment of the camera's aperture size. The third control operates the camera's zoom lens focal length and its focus. A separate control operates the tilt adjustment of the shearing mirrors within the camera to enable the ability to shear the image both horizontally and vertically independent of one another. The shearography laser controls allow the laser to be rotated in the vertical plane (tilt) and in the horizontal plane (pan) with an expansion adjustment to disperse the laser as needed.

6.1.3 *Image Capture and Processing Computer*—The computer must be capable of capturing and saving images when instructed. The computer must then have the ability of converting the images to a digital format to allow for multiple signal processing techniques to be applied. These techniques vary with each individual application. The computer should have the ability to place adjacent consecutive images next to one another to allow for a full field view of the inspected component.

6.1.4 *Stressing Device*—The stressing device shall be capable of introducing a loading into the article to be evaluated. This loading shall be capable of producing small nondestructive deformations on the part or component, which will produce stress within the article.

6.1.4.1 *Vacuum Stressing*—This type of stressing system consists of a sealed vacuum chamber, air movement device such as a blower, and vacuum relief valves located between the chamber and atmospheric pressure. The blower displaces air from inside the chamber to outside the chamber, thereby decreasing the pressure within the chamber. The decrease differential required to stress the tested article is typically in the 0.7 kPa to 14.0 kPa (0.1 psi to 2.0 psi) range. The vacuum relief valve is used to bring the pressure between the chamber and atmosphere to steady state.

6.1.4.2 *Thermal Stressing*—Any device that can introduce heat into the area of the article being evaluated may be used to increase test piece surface temperature. High intensity quartz lamps, and standard heat guns are commonly used. Manufactured thermal stressing devices with temperature measurement feedback are also used to provide a rapid, uniform temperature increase across the field of view on the test part.

6.1.4.3 *Pressure Stressing*—This system consists of a source of compressed gas meeting cleanliness requirements for the test article, associated valves and plumbing that are used to pressurize the test article. During inspection the article is brought up to a bias pressure greater than atmospheric pres-

sure. This bias pressure is used as a baseline for testing. The pressure is then cycled between a pressure either greater than or less than the bias pressure. The amount of pressure differential is a function of the tank material and geometry. The shearography data taken with increasing pressure will have a reverse phase compared to data taken with decreasing pressure.

6.1.4.4 *Acoustic Vibration Stressing*—The device must be capable of introducing small time dependant oscillations into the test article. This is commonly done using an air coupled acoustic device, which consists of a signal generator, a signal amplifier and an acoustic driver. The acoustic driver converts electrical energy to a highly focused acoustic pressure wave that travels through the air from the driver to the article being evaluated. The acoustic driver is strategically placed at a distance and angle to the evaluated article to optimize the ratio of longitudinal and shear waves entering the article.

6.1.4.5 *Mechanical Vibration Stressing*—A mechanically or vacuum attached piezoelectric actuator is an alternative vibration stressing device. This device consists of a signal generator, an actuator drive, and a linear mechanical actuator. The piezoelectric actuator is coupled rigidly to the component being tested. A sinusoidal signal or other waveform is then sent to the actuator causing a desired vibration and amplitude. This vibration is then transmitted through the test article.

6.1.5 *Test Specimen Fixture Apparatus*—The apparatus must perform the function of minimizing any movement that is not relative between the shearography camera and the article being evaluated. This type of unwanted movement will result in shearography image decorrelation.

6.1.5.1 *Polymer Matrix Composite and Sandwich Core Material Fixture*—The fixture consists of a device capable of rigidly supporting the monolithic or sandwich core material to minimize movement.

6.1.5.2 *Filament-Wound Pressure Vessel Fixture*—Refer to Guide E2982 for details associated with fixturing of filament-wound pressure vessels.

6.2 *Equipment Calibration*—Each shearography instrument or system, when calibration is required, shall have either a calibration sticker affixed, or record of certification on file, containing the following:

6.2.1 Instrument calibration.

6.2.2 Serial number.

6.2.3 Calibration date.

6.2.4 Calibration due date.

6.2.5 Name of individual who performed last calibration.

6.2.6 If calibration is not required, a sticker, stating no calibration is necessary shall be affixed, or a record shall be on file to this effect.

6.2.7 Shearography instruments and systems shall be calibrated against currently-certified standards calibrated by accepted government or industrial agencies (or shall indicate that it is calibrated as used, or that no calibration is necessary) at periodic intervals where specified.

6.3 *Facility Qualification*—If specified in the contractual agreement, NDE facilities shall be qualified and evaluated in accordance with Practice E543. The applicable revision of Practice E543 shall be specified in the contractual agreement.