



Designation: F366 – 24

Standard Specification for Fixation Pins and Wires¹

This standard is issued under the fixed designation F366; the number immediately following the designation indicates the year of original adoption or, in the case of revision, the year of last revision. A number in parentheses indicates the year of last reappraisal. A superscript epsilon (ϵ) indicates an editorial change since the last revision or reappraisal.

1. Scope*

1.1 This specification covers functional dimensions for fixation pins and wires.

1.2 In recognition of many broad and varied uses of such pins and wires, many options are included. A variety, but not necessarily all, of the options are illustrated in [Figs. 1-3](#).

1.3 The values stated in SI units are to be regarded as standard. No other units of measurement are included in this standard.

1.4 *This standard does not purport to address all of the safety concerns, if any, associated with its use. It is the responsibility of the user of this standard to establish appropriate safety, health, and environmental practices and determine the applicability of regulatory limitations prior to use.*

1.5 *This international standard was developed in accordance with internationally recognized principles on standardization established in the Decision on Principles for the Development of International Standards, Guides and Recommendations issued by the World Trade Organization Technical Barriers to Trade (TBT) Committee.*

2. Referenced Documents

2.1 *ASTM Standards:*²

[F86 Practice for Surface Preparation and Marking of Metallic Surgical Implants](#)

[F368 Specification for Fixation Pins-Knowles and Hagie Types \(Withdrawn 1982\)](#)³

[F2503 Practice for Marking Medical Devices and Other Items for Safety in the Magnetic Resonance Environment](#)

¹ This specification is under the jurisdiction of ASTM Committee F04 on Medical and Surgical Materials and Devices and is the direct responsibility of Subcommittee F04.21 on Osteosynthesis.

Current edition approved Jan. 1, 2024. Published January 2024. Originally approved in 1973. Last previous edition approved in 2017 as F366 – 17. DOI: 10.1520/F0366-24.

² For referenced ASTM standards, visit the ASTM website, www.astm.org, or contact ASTM Customer Service at service@astm.org. For *Annual Book of ASTM Standards* volume information, refer to the standard's Document Summary page on the ASTM website.

³ The last approved version of this historical standard is referenced on www.astm.org.

3. Materials

3.1 Fixation pins shall be fabricated from a metallic material intended for surgical implant applications. In addition, the materials shall be biocompatible for the intended application. Materials should be chosen based on the design requirements of the particular device. ASTM Subcommittee F04.12 maintains a number of specifications for materials that are suitable for surgical implant applications.

4. Performance Requirements

4.1 Factors considered to be important, but for which values and test methods have not been established, are bending strength, fatigue strength, breaking strength (Knowles type only), torsion strength, and ductility.

5. Dimensions and Characteristics

5.1 Fixation pins and wires shall be fabricated in accordance with the dimensions illustrated in [Figs. 1-4](#).

5.2 Fixation pins and wires shall have surfaces prepared and marked in accordance with Practice [F86](#).

5.2.1 Optional marking on the fixation pins and wires shall identify the manufacturer or distributor.

6. Packaging and Labeling

6.1 Packaging shall be adequate to protect the fixation pins and wires during shipment.

6.2 Labeling for fixation pins and wires shall include:

6.2.1 Product name,

6.2.2 Size, on the immediate container,

6.2.2.1 Length,

6.2.2.2 Diameter (if round) or cross-sectional size (if square or hexagonal), that is, 6.4 mm square, and

6.2.3 ASTM material specification designation number.

6.3 Consider Practice [F2503](#) to identify potential hazards produced by interactions between the device and the MR environment and for terms that may be used to label the device for safety in the MR environment.

7. Keywords

7.1 fixation materials; flexible surgical wire; orthopaedic medical devices; wire-surgical implants

*A Summary of Changes section appears at the end of this standard

ASTM F366 - 24

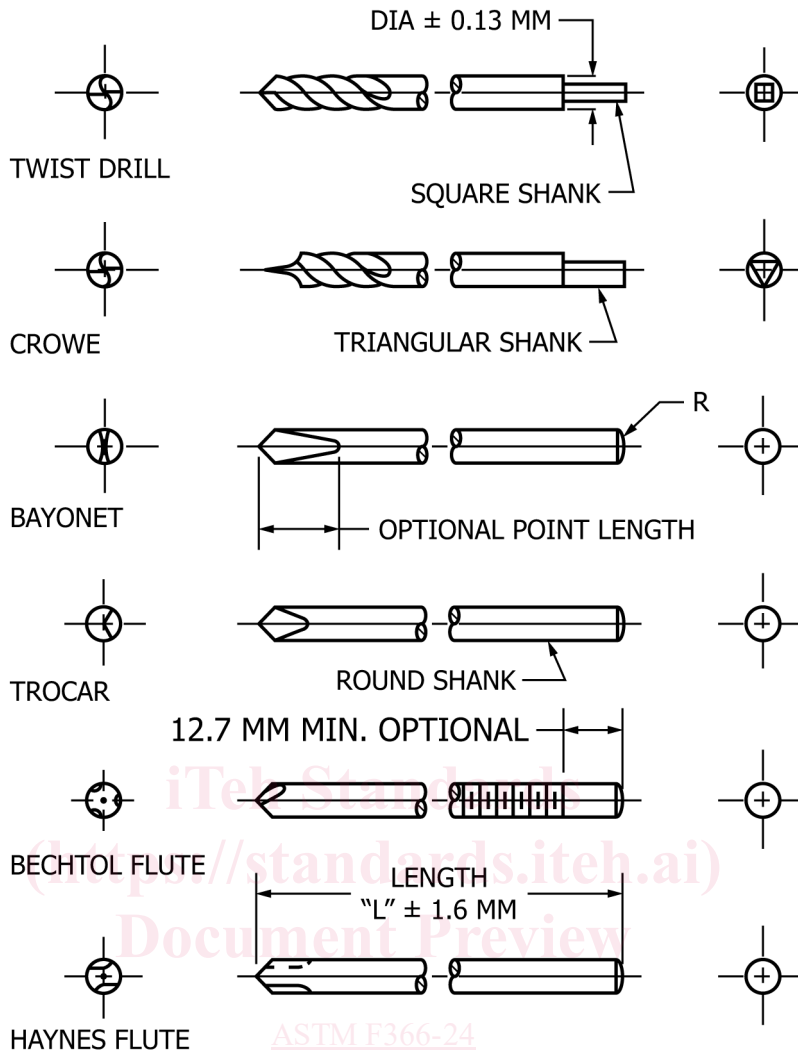

- NOTE 1—Pins and wires may be smooth shank or threaded.
- NOTE 2—Point angle and helix angle, where applicable, is as specified by the manufacturer.
- NOTE 3—On square or triangular shanks, flats are equal and corners are on the same circumference as the pin diameter. Shank diameters on pins larger than 3.2 mm may be reduced.
- NOTE 4—Optional designs, both ends pointed or point with suture hole.

FIG. 1 Fixation Pins and Wires