



Designation: D3466 – 06 (Reapproved 2023)

# Standard Test Method for Ignition Temperature of Granular Activated Carbon<sup>1</sup>

This standard is issued under the fixed designation D3466; the number immediately following the designation indicates the year of original adoption or, in the case of revision, the year of last revision. A number in parentheses indicates the year of last reapproval. A superscript epsilon ( $\epsilon$ ) indicates an editorial change since the last revision or reapproval.

## 1. Scope

1.1 This test method covers the determination of reference ignition temperature of granular activated carbon in flowing air. This test method provides a basis for comparing the ignition characteristics of different carbons, or the change in ignition characteristics of the same carbon after a period of service.

1.2 The ignition temperature, as determined by this test method, cannot be interpreted as the probable ignition temperature of the same carbon under the operating conditions of a specific application unless those conditions are essentially the same as those in this test method.<sup>2</sup> If it is desired to determine the ignition temperature of the carbon under a specific set of operating conditions, the test may be modified to simulate such conditions, taking into consideration the following variables: (1) air flow rate; (2) moisture content of the carbon; (3) bed depth; (4) relative humidity of the air stream; (5) heating rate; (6) contaminants (for example, hydrocarbons, etc.) in the air stream; and (7) contaminants that may have been adsorbed by the carbon under prior service conditions.

1.3 The values stated in SI units are to be regarded as standard. No other units of measurement are included in this standard.

1.4 *This standard does not purport to address all of the safety concerns, if any, associated with its use. It is the responsibility of the user of this standard to establish appropriate safety, health, and environmental practices and determine the applicability of regulatory limitations prior to use.* Specific precautionary statements are given in Section 7.

1.5 *This international standard was developed in accordance with internationally recognized principles on standardization established in the Decision on Principles for the Development of International Standards, Guides and Recommendations issued by the World Trade Organization Technical Barriers to Trade (TBT) Committee.*

<sup>1</sup> This test method is under the jurisdiction of ASTM Committee D28 on Activated Carbon and is the direct responsibility of Subcommittee D28.04 on Gas Phase Evaluation Tests.

Current edition approved Dec. 1, 2023. Published January 2024. Originally approved in 1976. Last previous edition approved in 2018 as D3466 – 06 (2018). DOI: 10.1520/D3466-06R23.

<sup>2</sup> Suzin, Y., et al., *Carbon*, Vol 37, 1999, pp. 335–346.

## 2. Referenced Documents

### 2.1 ASTM Standards:<sup>3</sup>

D2652 Terminology Relating to Activated Carbon

D2854 Test Method for Apparent Density of Activated Carbon

D3195/D3195M Practice for Rotameter Calibration

E11 Specification for Woven Wire Test Sieve Cloth and Test Sieves

E220 Test Method for Calibration of Thermocouples By Comparison Techniques

E300 Practice for Sampling Industrial Chemicals

## 3. Terminology

3.1 *Definitions*—Terms relating to this test method are defined in Terminology D2652.

## 4. Summary of Test Method

4.1 A sample of carbon is exposed to a heated air stream, the temperature of which is slowly increased until the carbon ignites. The temperature of the carbon bed and of the air entering the bed are recorded, and ignition is defined as the point at which the carbon temperature suddenly rises above the temperature of the air entering the bed.

## 5. Significance and Use

5.1 Activated carbons used in gas-phase adsorption may be subjected to heating, either from heat applied externally to the carbon bed, or heat generated by radioactive<sup>4</sup> contaminants, or by the adsorption process itself. If the application of heat is sudden, or if no ample means to conduct the heat from the carbon bed exists, the carbon bed may ignite. This test method provides a controlled laboratory test to determine the temperatures at which such ignition occurs. As stated in 1.2, this does not necessarily give the temperature at which ignition will occur under a specific bed operating condition. This test method does, however, allow some ranking of carbons with

<sup>3</sup> For referenced ASTM standards, visit the ASTM website, www.astm.org, or contact ASTM Customer Service at service@astm.org. For *Annual Book of ASTM Standards* volume information, refer to the standard's Document Summary page on the ASTM website.

<sup>4</sup> Milham and Kovocho, "Treatment of Airborne Radioactive Wastes," International Atomic Energy Agency, Vienna, 1968 (Paper SM-110/49).

regard to ignition temperature, and is a useful quality control method for unused carbons.

**6. Apparatus**

6.1 *Quartz Ignition Tube and Sample Holder*, as shown in Fig. 1.

6.2 *Thermocouples*, Chromel-Alumel with Inconel sheath, 0.635 mm diameter, three required.

6.3 *Supply of Clean, Dry, Oil-Free Air*—The air must be passed through a HEPA filter and a bed of activated carbon containing at least 300 mL of carbon per litre per minute of air flow. Relative humidity of the air must be less than 5 % at 25 °C.

6.4 *Flowmeter*, capable of metering air flow rates to 20 L/min.

6.5 *Heating Mantle*, tape, or oven to surround the ignition tube; at least 50 W.

6.6 *Variable Transformer* or temperature programmer for heater.

6.7 *Supply of Compressed Nitrogen*.

6.8 *Quartz Beads*, 4 mm in diameter or smaller, as needed to prevent fluidization.

6.9 *Sieves* (two), 76.2 mm in diameter, 150 µm conforming to Specification E11.

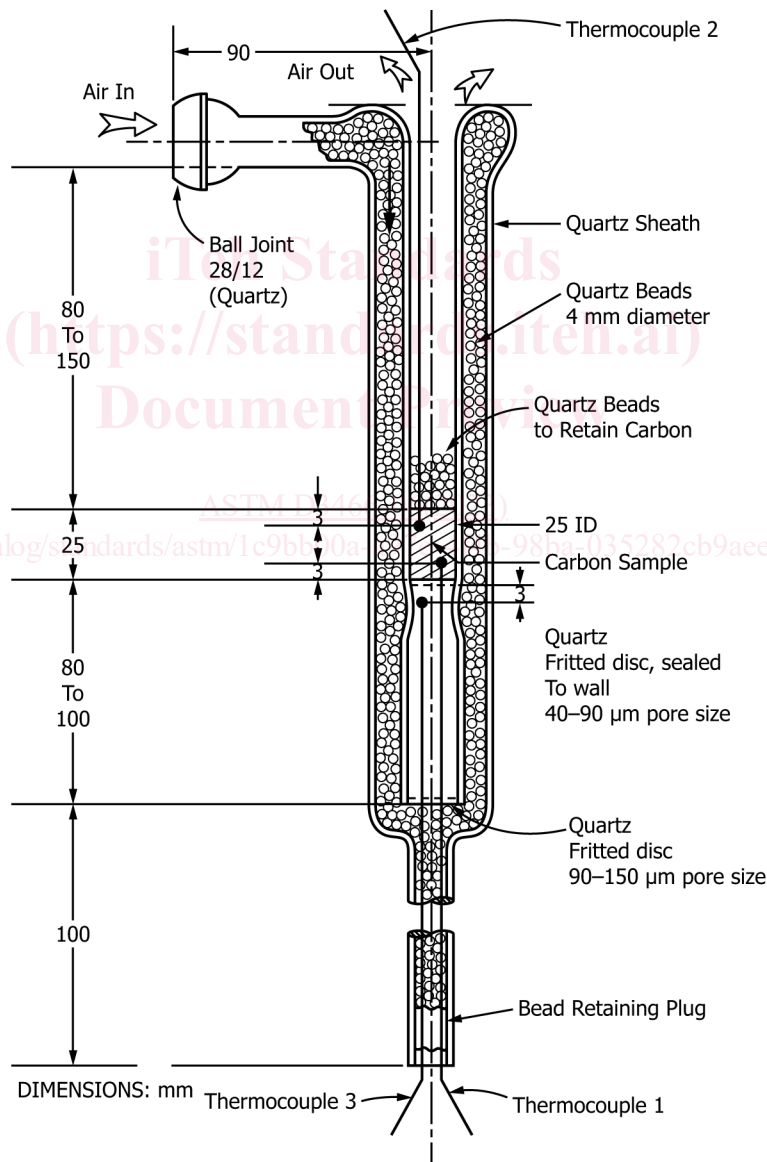

FIG. 1 Ignition Tube and Sample Assembly