



Designation: D6425 – 23

# Standard Test Method for Measuring Friction and Wear Properties of Extreme Pressure (EP) Lubricating Oils Using SRV Test Machine<sup>1</sup>

This standard is issued under the fixed designation D6425; the number immediately following the designation indicates the year of original adoption or, in the case of revision, the year of last revision. A number in parentheses indicates the year of last reapproval. A superscript epsilon ( $\epsilon$ ) indicates an editorial change since the last revision or reapproval.

## INTRODUCTION

This test method represents the transformation of DIN 51834-2:1997. The DIN working group implemented changes at its annual meeting in Munich in September 2000. ASTM Committee D02 adopted these modifications as closely as possible. The DIN working group widens the scope of the standard to accommodate different test conditions and refines repeatability and reproducibility on the base of four international RR tests. It also introduces the wear volume as a tribological quantity.

## 1. Scope\*

1.1 This test method covers an extreme pressure (EP) lubricating oil's coefficient of friction and its ability to protect against wear when subjected to high-frequency, linear oscillation motion. The procedure is identical to that described in DIN 51834.

1.2 This test method can also be used to determine the ability of a non-EP lubricating oil to protect against wear and its coefficient of friction under similar test conditions.

1.3 The values stated in SI units are to be regarded as standard. No other units of measurement are included in this standard.

1.4 *This standard does not purport to address all of the safety concerns, if any, associated with its use. It is the responsibility of the user of this standard to establish appropriate safety, health, and environmental practices and determine the applicability of regulatory limitations prior to use.*

1.5 *This international standard was developed in accordance with internationally recognized principles on standardization established in the Decision on Principles for the Development of International Standards, Guides and Recommendations issued by the World Trade Organization Technical Barriers to Trade (TBT) Committee.*

<sup>1</sup> This test method is under the jurisdiction of ASTM Committee D02 on Petroleum Products, Liquid Fuels, and Lubricants and is the direct responsibility of Subcommittee D02.L0.11 on Tribological Properties of Industrial Fluids and Lubricates.

Current edition approved Nov. 1, 2023. Published January 2024. Originally approved in 1999. Last previous edition approved in 2019 as D6425 – 19. DOI: 10.1520/D6425-23.

## 2. Referenced Documents

### 2.1 ASTM Standards:<sup>2</sup>

A295 Specification for High-Carbon Anti-Friction Bearing Steel

D235 Specification for Mineral Spirits (Petroleum Spirits) (Hydrocarbon Dry Cleaning Solvent)

D4175 Terminology Relating to Petroleum Products, Liquid Fuels, and Lubricants

D5706 Test Method for Determining Extreme Pressure Properties of Lubricating Greases Using a High-Frequency, Linear-Oscillation (SRV) Test Machine

D7421 Test Method for Determining Extreme Pressure Properties of Lubricating Oils Using High-Frequency, Linear-Oscillation (SRV) Test Machine

D7755 Practice for Determining the Wear Volume on Standard Test Pieces Used by High-Frequency, Linear-Oscillation (SRV) Test Machine

E45 Test Methods for Determining the Inclusion Content of Steel

G40 Terminology Relating to Wear and Erosion

### 2.2 DIN Standards:<sup>3</sup>

DIN EN ISO 683-17 Heat-treated steels, alloy steels and free-cutting steels—Part 17 : Ball and roller bearing steels

DIN 51631:1999 Mineral spirits; special boiling point spirits; requirements

<sup>2</sup> For referenced ASTM standards, visit the ASTM website, [www.astm.org](http://www.astm.org), or contact ASTM Customer Service at [service@astm.org](mailto:service@astm.org). For *Annual Book of ASTM Standards* volume information, refer to the standard's Document Summary page on the ASTM website.

<sup>3</sup> Available from Deutsches Institut für Normung, Beuth Verlag GmbH, Burggrafenstrasse 6, D-10787 Berlin, Germany.

\*A Summary of Changes section appears at the end of this standard

**DIN 51834 Tribological Test in the Translatory Oscillation Apparatus (Part 2: Determination of Friction and Wear Data for Lubricating Oils)**

**DIN EN ISO 13565-2:1998 Geometrical Product Specifications (GPS)—Surface Texture: Profile Method; Surfaces having Stratified Functional Properties—Part 2: Height Characterization using Linear Material Ratio Curve (replacement of DIN 4776:1990)**

### 3. Terminology

#### 3.1 Definitions:

3.1.1 *break-in, n*—in tribology, an initial transition process occurring in newly established wearing contacts, often accompanied by transients in coefficient of friction or wear rate, or both, that are uncharacteristic of the given tribological system's long term behavior. (Synonym: **run-in, wear-in**) **G40**

3.1.2 *coefficient of friction  $\mu$  or  $f$ , n*—in tribology, the dimensionless ratio of the friction force ( $F_f$ ) between two bodies to the normal force ( $F_n$ ) pressing these bodies together. **G40**

$$\mu = (F_f / F_n) \quad (1)$$

3.1.3 *EP lubricating oil, n*—a liquid lubricant containing an extreme pressure (EP) additive

3.1.4 *extreme pressure (EP) additive, n*—in a lubricant, a substance that minimizes damage to metal surfaces in contact under high stress rubbing conditions.

3.1.5 *Hertzian contact area, n*—the apparent area of contact between two nonconforming solid bodies pressed against each other, as calculated from Hertz' equations of elastic deformation. **G40**

3.1.6 *Hertzian contact pressure, n*—magnitude of the pressure at any specified location in a Hertzian contact area, as calculated from Hertz's equations of elastic deformation. The Hertzian contact pressure can also be calculated and reported as maximum value  $P_{\max}$  in the centre of the contact or as  $P_{\text{average}}$  as average over the total contact area. **D7421**

3.1.7 *lubricant, n*—any substance interposed between two surfaces for the purpose of reducing the friction or wear between them. **G40**

3.1.8  *$P_{\text{geom}}$ , n*—geometric contact pressure describes the load carrying capacity at test end.

3.1.9 *Ra (C.L.A.), n*—in measuring surface finish, the arithmetic average of the absolute distances of all profile points from the mean line for a given distance.<sup>4</sup>

3.1.10 *RpK, n*—Reduced peak height according to DIN EN ISO 13565-2:1998. Half the RpK value is the mean height of the peak sticking out above the core profile section.

3.1.11 *RvK, n*—Reduced valley height according to DIN EN ISO 13565-2:1998. RvK is the mean depth of the valley reaching into the material below the core profile section.

3.1.12 *Rz (DIN), n*—in measuring surface finish, the average of all  $R_y$  values (peak to valley heights) in the assessment length.<sup>4</sup>

3.1.13 *wear, n*—damage to a solid surface, generally involving progressive loss of material, due to relative motion between that surface and a contacting substance or substances. **G40**

3.1.14 *Wv, n*—wear volume is the loss of volume to the ball or disk after a test.

#### 3.2 Definitions of Terms Specific to This Standard:

3.2.1 *seizure, n*—localized fusion of metal between the rubbing surfaces of the test pieces. **D5706**

3.2.1.1 *Discussion*—In this test method, seizure is indicated by a sharp rise in the coefficient of friction, over steady state, of greater than 0.2 for over 20 s. In severe cases, a stoppage in the motor will occur.

#### 3.3 Abbreviations:

3.3.1 *SRV, n*—Schwingung, Reibung, Verschleiss, (German); oscillating, friction, wear, (English translation). **D5706**

### 4. Summary of Test Method

4.1 This test method is performed on an SRV test machine using a test ball oscillated at constant frequency and stroke amplitude and under constant load ( $F_n$ ), against a test disk that has been moistened with the lubricant specimen. The platform to which the test disk is attached is held at a constant temperature.

NOTE 1—The frequency of oscillation, stroke length, test temperature, test load, test duration, and test ball and disk material can be varied from those specified in this test method. The test ball yields Hertzian point contact geometry. To obtain line or area contact, test pieces of differing configurations can be substituted for the test ball.

4.2 The friction force,  $F_f$ , is measured by a piezo-electric device in the test disk assembly. Peak values of coefficient of friction,  $f$ , are determined and recorded as a function of time.

4.3 After a preset test period, the test machine and chart recorder are stopped and the wear scar on the ball is measured. If a profilometer is available, a trace of the wear scar on the test disk can also be used to obtain additional wear information.

### 5. Significance and Use

5.1 This test method can be used to determine antiwear properties and coefficient of friction of EP lubricating oils at selected temperatures and loads specified for use in applications in which high-speed vibrational or start-stop motions are present for extended periods of time under initial high Hertzian point contact pressures. It has found application as a screening test for lubricants used in gear or cam/follower systems. Users of this test method should determine whether results correlate with field performance or other applications.

### 6. Apparatus

6.1 *SRV Test Machine*<sup>5</sup> illustrated in Figs. 1-4, consists of an oscillation drive, a test chamber (see Fig. 2 and Fig. 4), and

<sup>5</sup> The sole source of supply known to the committee at this time is Optimol Instruments Prüftechnik GmbH, Flößergasse 3, D-81369 München, Germany. If you are aware of alternative suppliers, please provide this information to ASTM Headquarters. Your comments will receive careful consideration at a meeting of the responsible technical committee,<sup>1</sup> which you may attend.

<sup>4</sup> Amstutz, Hu, "Surface Texture: The Parameters," Bulletin MI-TP-003-0785, Sheffield Measurement Division, Warner and Swazey, 1985, p. 21.

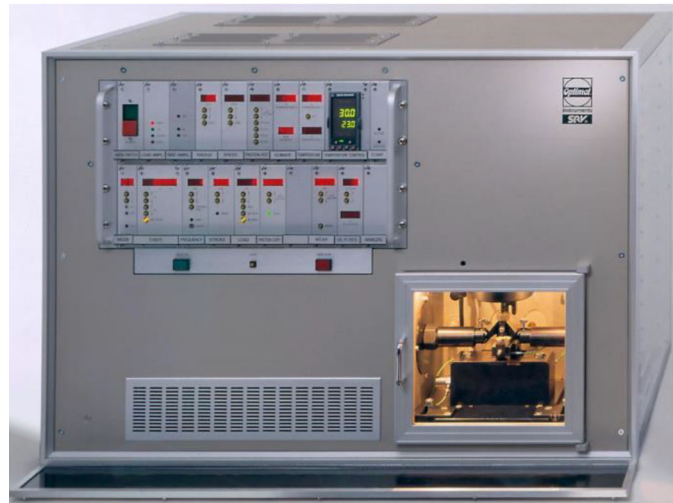
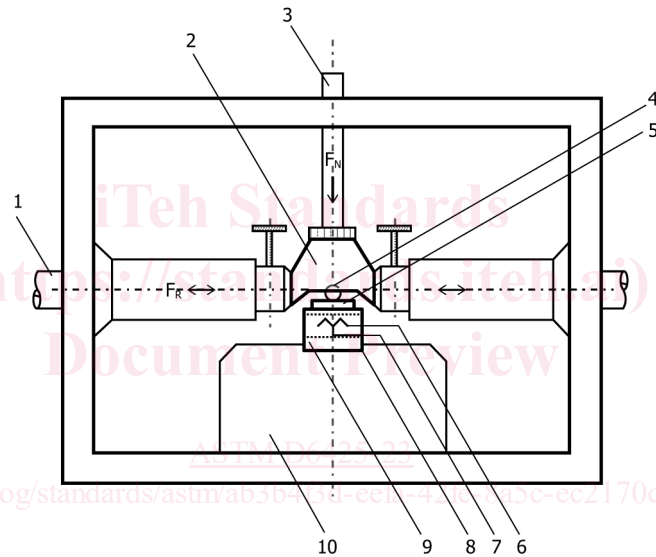

FIG. 1 SRV Test Machine (Model III)



- 1. Oscillation drive rod
- 2. Test ball holder
- 3. Load rod
- 4. Test ball
- 5. Test disk

- 6. Electrical resistance heater
- 7. Resistance thermometer
- 8. Test disk holder
- 9. Piezoelectric measuring device
- 10. Receiving block

FIG. 2 Test Chamber Elements of SRV III

a loading device<sup>6</sup> with a servomotor and a load cell. The machine is operated by a control device for the oscillating drive, a timer, a load control, a frequency control, a stroke control, a data amplifier to determine the friction coefficient, and a switch and a controller for the heating. An oscilloscope may be used for monitoring. Friction coefficients are recorded in relation to time by a chart recorder, or by data acquisition in a computer.

<sup>6</sup> Optimol Instruments supplies an upgrade kit to allow older machines to operate with 1600 N, if needed.

6.1.1 On the firmly mounted receiving block (1) in the test chamber (see Fig. 2 and Fig. 4), there is a piezoelectric device (2) to measure the friction force,  $F_f$ , and the friction coefficient,  $f$ ; the holder for the test disk (3) with a thermostat-controlled electrical resistance heating element (4); a resistance thermometer (5); the oscillation drive rods (6); an exchangeable holder for the test ball (7); and the load rods of the loading device (8).

6.1.2 The design of the receiving block for the test disk should be such that it has integrated cooling coils, or that cooling coils are wound around it, so that the receiving block must be capable to maintaining test temperatures down to



FIG. 3 Test Machine (Model IV)

+233 K. The test disk (9) and the test ball (10) are inserted into their respective holders (3, 4) (see Fig. 2 and Fig. 4).

6.1.3 Disks are generally used as the lower test piece. Balls, cylinders, rings, or specialized shapes may be used, with appropriate holders, as the upper test piece (see Fig. 5).

6.2 *Microscope*, equipped with a filar eyepiece graduated in 0.005 mm divisions or equipped with a micrometre stage readable to 0.005 mm. Magnification should be sufficient to allow for ease of measurement.

6.3 *Syringe*, suitable for applying 0.3 mL of the lubricating oil under test.

6.4 *Tweezers*, straight, round, about 200 mm long, with non-marring tips.

6.5 *Torque Wrench*, initial torque 0.5 Nm to 5 Nm.

6.6 *Ultrasonic Cleaner*.

## 7. Reagents and Materials

7.1 *Test Balls*,<sup>7</sup> AISI 52100 Steel, 60 HRC  $\pm$  2 HRC hardness, 0.025  $\mu$ m  $\pm$  0.005  $\mu$ m Ra (C.L.A.) surface finish, 10 mm diameter.

7.2 *Test Disk*,<sup>7</sup> vacuum arc remelted (VAR) AISI 52100 steel with an inclusion rating using method D, Type A, as severity level number of 0,5 according to Test Methods E45 and Specification A295 or a inclusion sum value  $K1 \leq 10$  according to DIN EN ISO 683-17 and spheroidized annealed to obtain globular carbide, 62 HRC  $\pm$  1 HRC hardness, the surfaces of the disk being lapped and free of lapping raw materials. The

<sup>7</sup> ASM Handbook, "Friction, Lubrication, and Wear Technology," Vol 18, October 1992.

topography of the disk will be determined by four values: 0.500  $\mu$ m < Rz < 0.650  $\mu$ m; 0.035  $\mu$ m < Ra (C.L.A.) < 0.050  $\mu$ m, 0.020  $\mu$ m < Rpk < 0.035  $\mu$ m and 0.050  $\mu$ m < Rvk < 0.075  $\mu$ m, 24 mm  $\pm$  0.5 mm diameter by 7.85 mm  $\pm$  0.1 mm thick.

NOTE 2—DIN 17230-1980 was replaced by DIN EN ISO 683-17.

7.3 *Cleaning Solvent*, single boiling point spirit type 2-A according to DIN 51631-1999 (published in English). (**Warning**—Flammable. Health hazard.)

NOTE 3—In the case of unavailability, please refer to Specification D235 regarding Type I, Class C (with less than 2 % by volume of aromatics), mineral spirits.

## 8. Preparation of Apparatus

8.1 *Preparation of SRV I and II Models:*

8.1.1 Turn on the test machine and chart recorder and allow to warm up for 15 min prior to running tests.

8.1.2 Select the friction data to be presented in the crest peak value position in accordance with the manufacturer's directions.

NOTE 4—In most cases, this is accomplished by positioning the sliding switch on electronic card No. 291.35.20E (front side of electronics behind front panel) and the sliding switch located on the back panel of the control unit.

8.1.3 Turn the amplitude knob to ZERO.

8.1.4 Switch the stroke adjustment to AUTO position.

8.1.5 Set the frequency to 50 Hz and duration to 2 h, 00 min, 30 s in accordance with the manufacturer's instructions.

8.1.6 Set the load charge amplifier to the setting that corresponds to the load foreseen for the test in accordance with the manufacturer's instructions. The test can be run at constant normal forces selected in +100 N increments starting at +100 N.

8.1.7 Set the desired span, and calibrate the chart recorder in accordance with the manufacturer's instructions. Select the desired chart speed.

NOTE 5—In later SRV models, the load charge amplifier is set automatically.

8.2 *Preparation of SRV III, IV, and V Models:*

8.2.1 When using SRV III, SRV IV, and SRV V models, clean and install the specimens as specified under 9.1. Turn on the test machine and the PC and allow to warm up for 15 min prior to running tests.

8.2.2 Create a set point profile in the SRV control software with the following parameters.

NOTE 6—Depending on the software version, names and availability of the parameters can vary.

8.2.2.1 Start conditions (thermostatic stabilization):

Temperature: for example, 50 °C  $\pm$  1 K or 80 °C  $\pm$  1 K or 120 °C  $\pm$  1 K  
 Test load: 50 N  $\pm$  1 N  
 Start delay: 600 s (is displayed by all versions of the SRV software)

8.2.2.2 Cut-off criteria for friction, if occurs:

Coefficient of friction, f (cut-off value for permanent increase of level):  
 0.3 during  $t > 20$  s  
 Coefficient of friction, f (cut-off value for one-off increase of level): 0.35

8.2.3 Test parameters:



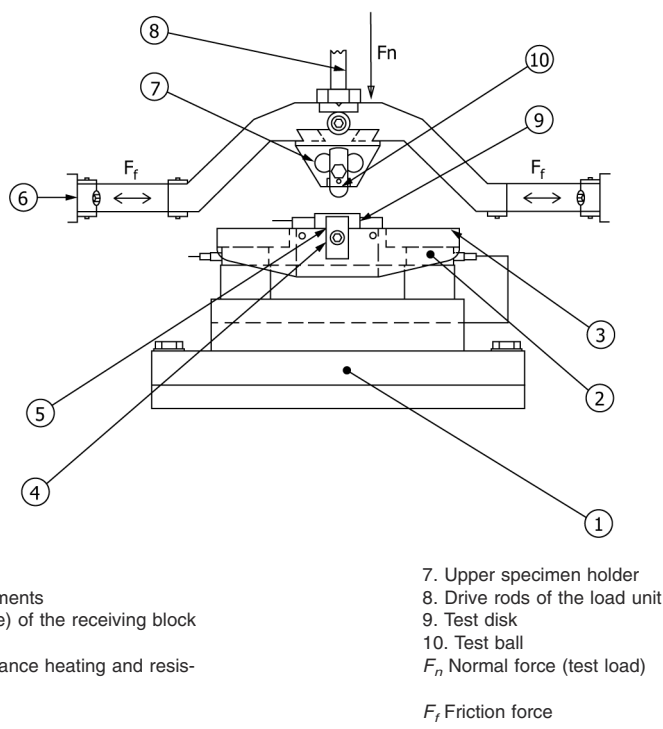

FIG. 4 Test Chamber Elements of SRV Models IV and V

Frequency: 50 Hz  
 Stroke: 1.00 mm  
 Temperature: for example, 50 °C or 80 °C or 120 °C  
 Pre-load: 50 N for 30 s  
 Test load: running-in under 50 N for 30 s, then constant load of 300 N

8.2.4 Sample rates for result-relevant measurement channels:

Coefficient of friction,  $f$ :  $\leq 32$  ms  
 Stroke:  $\leq 2$  s  
 Test load:  $\leq 2$  s  
 Frequency:  $\leq 2$  s  
 Temperature:  $\leq 2$  s

NOTE 7—For SRV V models, it is recommended to do one sampling per period (that is, 20 ms) for coefficient of friction and stroke.

9. Procedure

Procedure for All SRV Models

9.1 Installation of the Test Pieces and Lubricating Oil Specimen in the Test Chamber:

9.1.1 Using solvent resistant gloves, clean the test ball, ball holder, and disk by wiping the surfaces with laboratory tissue soaked with cleaning solvent (single boiling point spirit type 2-A according to DIN 51631). **(Warning—**This mixture is flammable and a health hazard.) Repeat wiping until no dark residue appears on the tissue. Immerse the ball and disk in a beaker of the cleaning solvent under ultrasonic vibration (if available) for 10 min. Dry the ball holder. Dry the test ball and disk with a clean tissue, ensuring that no streaking occurs on the surface.

9.1.2 Ensure that the test load unit is in the release position (refer to your operating manual for details).

9.1.3 Place 0.3 mL of the lubricating oil to be tested on the cleaned disk. Then install the disk (place on the block). Tighten the fastening screw until resistance just begins.

9.1.4 Place the cleaned ball, using the tweezers, in the disassembled, cleaned, and dried ball holder. Tighten the fastening screw until resistance just begins.

9.1.5 Install the ball holder and test ball in the test chamber.

Procedure for SRV III, IV, and V Models

9.2 Procedure for SRV III, IV, and V Models:

9.2.1 Open the Assistant for starting a test in the SRV control software. Select the created set-point profile and, if necessary (for example, SRV V), the data logger configuration and proceed through the Assistant until the pre-load has been applied.

9.2.2 Then set the test load unit to 50 N and release and re-tighten the ball and disk clamps to a torque of 2.5 Nm.

9.2.3 The heater control starts automatically and heats up to the pre-set and desired temperature: 50 °C, 80 °C, or 120 °C.

9.2.4 Follow the directions in the Assistant for starting a test in the SRV control software until the automated test run mode (waiting for reaching start conditions) is started. The test starts automatically when the pre-set delay (for example, 300 s) has expired. The test can also be started manually. The test machine will automatically stop.

Procedure for SRV I and II Models

9.3 Procedure for SRV I and II Models:

9.3.1 Turn on the heater control, and preheat the disk holder to 50 °C.

Holders for SRV model III	Holders for SRV models 4&5
	
Point	
	
Line	
	
Area	

FIG. 5 Test Pieces and Holders for Standard Tribological Contacts

9.3.2 Apply a load of 50 N, loosen the fastening screws on both disk and ball holders, and then immediately tighten them with a torque wrench to 2.5 Nm.

9.3.3 *Test Run:*

9.3.3.1 *Start of the Test Run:*

(1) Allow 10 min for the test pieces and test oil to reach and stabilize at the test temperature. The test can be run at constant temperatures selected in +10 K (+10 °C) increments starting at +233 K to +553 K (−40 °C to +280 °C).<sup>8</sup>

NOTE 8—An initial hardness of 62.5 HRC at room temperature of AISI 52100 will drop to 61 HRC after 100 h at 149 °C and will exist as a hot hardness of 60 HRC over 100 h.<sup>8</sup>

<sup>8</sup> Zaretsky, E. V., *Tribology for Aerospace Applications*, STLE SP-37, 1997, pp. 358.

(2) When the temperature has stabilized, turn on the chart recorder paper feed (or the computer) and lower the recording pens. Depress the drive start toggle switch until the timer begins to count and then adjust the stroke amplitude knob to 1.00 mm.

NOTE 9—Stroke should be checked periodically by measuring the wear track length minus the ball scar diameter. The difference must be smaller than ±10 % of the set stroke.

(3) When the digital timer reaches 30 s, increase the load to 300 N and run at that load for 2 h ± 15 s.

9.3.3.2 *Terminating the Test Run:*

(1) The test is automatically terminated by the timer when the preset test time has elapsed. The machine will automatically stop.

NOTE 10—Power automatically turns off at the end of the test.

NOTE 11—If, due to seizure, the friction coefficient exceeds the limit