



Standard Practice for Design and Installation of Rigid Pipe Hangers¹

This standard is issued under the fixed designation F708; the number immediately following the designation indicates the year of original adoption or, in the case of revision, the year of last revision. A number in parentheses indicates the year of last reapproval. A superscript epsilon (ϵ) indicates an editorial change since the last revision or reapproval.

This standard has been approved for use by agencies of the U.S. Department of Defense.

1. Scope

1.1 This practice covers acceptable methods of fabricating and installing rigid pipe hangers used to support shipboard piping systems with temperatures of 650 °F (343 °C) or less.

1.2 This practice provides guidance for the design of hanger caps, straps and standoffs, selection of hanger and hanger liner materials, hanger bolting, and hanger spacing.

1.3 Other hanger designs may be used provided they result in an adequately supported vibration-free piping system and are compatible with the intended system service and temperature limitations.

1.4 The values stated in inch-pound units are to be regarded as standard. The values given in parentheses are mathematical conversions to SI units that are provided for information only and are not considered standard.

1.5 *This standard does not purport to address all of the safety concerns, if any, associated with its use. It is the responsibility of the user of this standard to establish appropriate safety, health, and environmental practices and determine the applicability of regulatory limitations prior to use.*

1.6 *This international standard was developed in accordance with internationally recognized principles on standardization established in the Decision on Principles for the Development of International Standards, Guides and Recommendations issued by the World Trade Organization Technical Barriers to Trade (TBT) Committee.*

2. Referenced Documents

2.1 ASTM Standards:²

[A307 Specification for Carbon Steel Bolts, Studs, and Threaded Rod 60 000 PSI Tensile Strength](#)

¹ This practice is under the jurisdiction of ASTM Committee F25 on Ships and Marine Technology and is the direct responsibility of Subcommittee F25.11 on Machinery and Piping Systems.

Current edition approved Jan. 1, 2024. Published January 2024. Originally approved in 1981. Last previous edition approved in 2022 as F708 – 92 (2022). DOI: 10.1520/F0708-24.

² For referenced ASTM standards, visit the ASTM website, www.astm.org, or contact ASTM Customer Service at service@astm.org. For *Annual Book of ASTM Standards* volume information, refer to the standard's Document Summary page on the ASTM website.

3. Terminology

3.1 Definitions:

3.1.1 *liner, n*—the material used to isolate a pipe from its hanger.

3.1.2 *rider bar, n*—a protective strip of material installed between the pipe and the hanger where frequent linear movement of the pipe is expected.

3.1.3 *rigid pipe hanger, n*—a device that transfers the load imposed by the piping, insulation, and system medium to the supporting structure.

3.1.4 *standoff, n*—the rigid member that connects the hanger strap, saddle, or band to the supporting structure. A standoff is usually made up of one or more pieces of flat bar, pipe, angle bar, or flanged plate to suit a specific location.

4. List of Pipe Hanger Styles

4.1 This practice incorporates 26 pipe hanger assemblies as shown on [Figs. 1-9](#) as follows:

Hanger	Fig. No.
Split cap hanger (single leg standoff)	1(a)
Split cap hanger (dual leg standoff)	1(b)
Split cap hanger (chair type)	1(c)
Strap hanger	2(a)
Strap hanger (assembled for clearance with rider bar)	2(b)
Strap hanger (assembled for clearance with TFE-fluorocarbon strip)	2(c)
Welded hanger (flat bar U-type)	3(a)
Welded hanger (round bar U-type)	3(b)
Welded hanger (square bar U-type)	3(b)
U-bolt hanger	4(a)
U-bolt hanger (assembled for clearance with rider bar)	4(b)
U-bolt hanger (assembled for clearance with TFE-fluorocarbon strip)	4(c)
Welded hanger (single leg standoff welded direct to pipe)	5(a)
Welded hanger (dual leg standoff welded direct to pipe)	5(b)
“J” band type hanger (insulated pipe)	6(a)
“J” band type hanger (bare pipe)	6(b)
Clamp hanger assembled with mounting channel	7
Crimp-on weld stud-type hangers	8
Banded weld stud-type hanger	9

5. Hanger Designs

5.1 [Figs. 1-5](#) and [Fig. 6\(a\)](#) hangers are designs generally manufactured by shipyards or their subcontractors. See also [Tables 1-6](#).

5.2 Fig. 6, Fig. 7, Fig. 8, and Fig. 9 hangers are commercially available from various vendors. Fig. 7, Fig. 8, and Fig. 9 hangers are primarily designed for use in supporting electrical cables, but are suitable for hanging small size pipe and tubing.

6. Materials and Manufacture

6.1 Hanger materials for straps, saddles, and U-bolts for Figs. 1-5 hangers and standoffs should be fabricated from commercial quality carbon steel. The steel should be a weldable grade with a minimum tensile strength of 47 ksi (324 MPa) and capable of being bent at room temperature through 90° to an inside radius equal to the material thickness without cracking on the outside of the bend.

6.2 Hangers in Fig. 1, Fig. 6, Fig. 8, and Fig. 9 are generally manufactured from carbon steel. Fig. 7 is furnished in carbon steel and stainless steel.

6.3 Bands and buckles for Fig. 6 and Fig. 9 hangers should be carbon steel electroplated zinc or stainless steel.

6.4 Hanger bolts and nuts should be regular series hex type electroplated zinc with unified national coarse threads Class 2 fit in accordance with Specification A307, Grade B.

6.5 Table 7 is a listing of hanger liner materials generally used to isolate the pipe from the hanger (see 9.1.1).

7. Application and Limitations

7.1 Unless otherwise noted, application and limitations on the use of various style hangers should be as noted with each hanger detail.

8. Hanger Spacing

8.1 Table 8 provides general guidance in determining pipe hanger spacing. Special consideration should be given to areas of concentrated loads, such as risers, valves, or groups of fittings, and to piping configurations that could create rotational forces.

9. General Requirements

9.1 The following general requirements and conditions are applicable to all styles of hangers:

9.1.1 Hangers need not be lined unless the hanger and pipe are of dissimilar material, or when the system internal operating temperature is 300 °F (149 °C) and over, or 50 °F (10 °C) and under and the heat transmitted to the other side of the structure to which the hanger is attached may be objectionable. For hanger liner materials, see 6.5.

9.1.2 All hanger bolts within tanks or other inaccessible areas shall be secured with lock nuts, lock washers, or by some other means.

9.1.3 Pipe hangers and standoffs located in areas subject to corrosion, such as in bilges, ballast tanks, and areas exposed to the weather, should be zinc-plated or blasted and coated with inorganic zinc or coated with the same material as that of the surrounding area.

9.1.4 Standoffs fabricated from pipe should not be used within tanks.

9.1.5 Where thermal growth of piping exceeds 0.100 in. (2.5 mm) or long runs of pipe are affected by ship flexing, such as long runs on the weather deck, or long runs in longitudinal passageways, a metal rider bar attached to the pipe or a TFE-fluorocarbon wear strip should be used in conjunction with a clearance type hanger, or other means should be provided to prevent chaffing of the pipe.

9.1.6 Consideration should be given to thermal growth of the piping when selecting or locating hangers so as not to overstress the piping or hangers.

9.1.7 Nonmetallic pipe should be hung in accordance with the manufacturer's recommendations.

10. Workmanship, Finish, and Appearance

10.1 Finished hanger components shall have a workmanlike appearance and be free of cracks or other injurious defects. Surface scale, rust, welding slag, or any foreign material (such as oil) shall be removed before painting or coating.

11. Keywords

11.1 design; fabrication; installation; piping systems; rigid pipe hangers

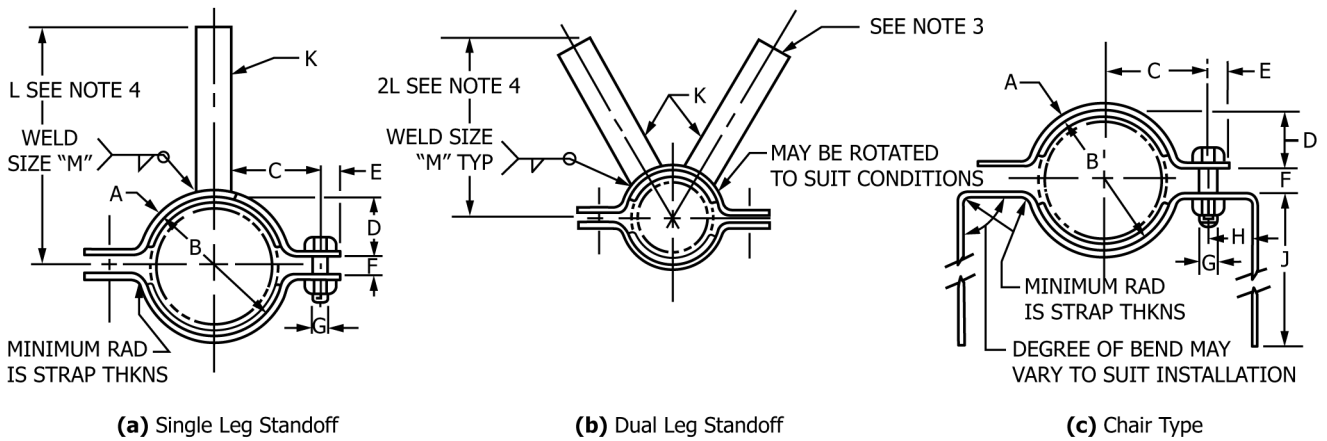

NOTE 1—For dimensions of hangers, see Table 1.
 NOTE 2—These hangers are suitable for use in all locations, including tanks and areas exposed to the weather, and can be used lined or unlined.
 NOTE 3—For Fig. 1(b), length of standoff legs may be unequal and angle of attachment may vary as required to suit conditions.
 NOTE 4—Maximum length of standoff “L” shall be as follows: flat bar = 18-in.; pipe = 30-in.; and angle bar = 42-in.

FIG. 1 Split Cap Hangers

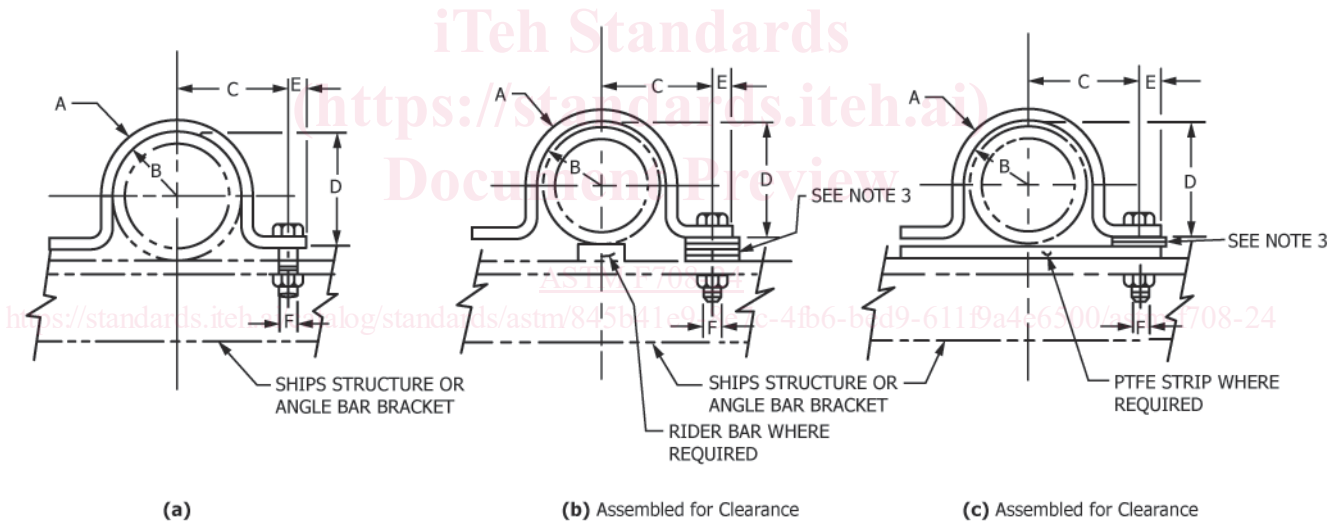

NOTE 1—For dimensions of hangers, see Table 2.
 NOTE 2—These hangers are suitable for use in all locations, including tanks and areas exposed to the weather, and can be used lined or unlined.
 NOTE 3—Install standard flat washers as necessary to unlined strap to provide 1/32 in. to 1/8 in. (0.8 mm to 3.2 mm) clearance for linear motion of piping when required.

FIG. 2 Strap Hangers

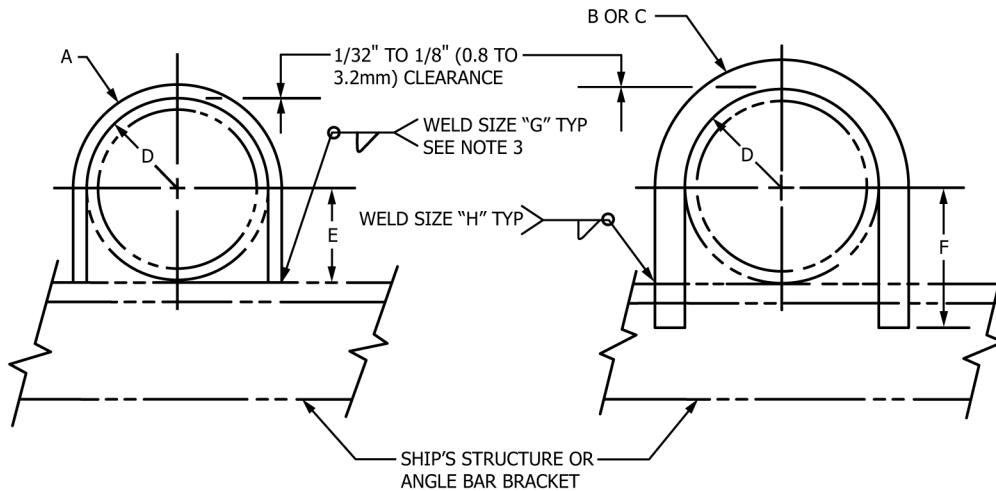

(a) Flat Bar U-Type

(b) Round and Square Bar U-Type

NOTE 1—For dimensions of hangers, see Table 3.

NOTE 2—These hangers are suitable for use in all locations, including tanks and areas exposed to the weather, and are intended to be used unlined only.

NOTE 3—Weld as indicated for size 3-in. NPS and above. For 2½-in. NPS and below, weld hanger on outside only.

FIG. 3 Welded Hangers

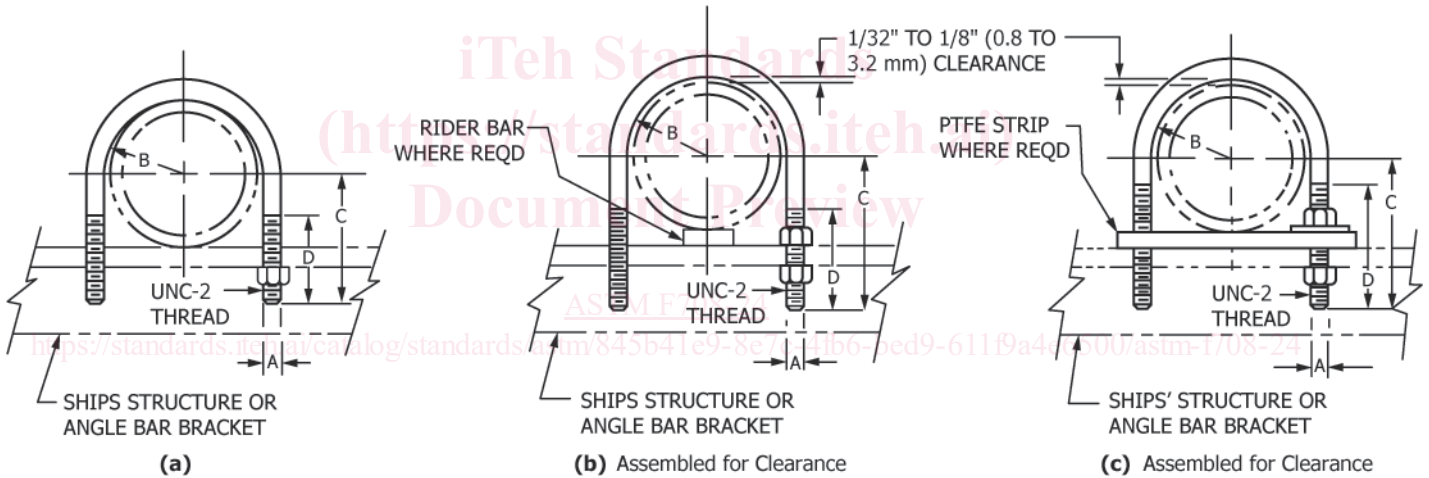

(a)

(b) Assembled for Clearance

(c) Assembled for Clearance

NOTE 1—For dimensions of hangers, see Table 4.

NOTE 2—These hangers are suitable for use in all locations, including tanks and areas exposed to the weather, and are intended to be used unlined.

FIG. 4 U-Bolt Hangers

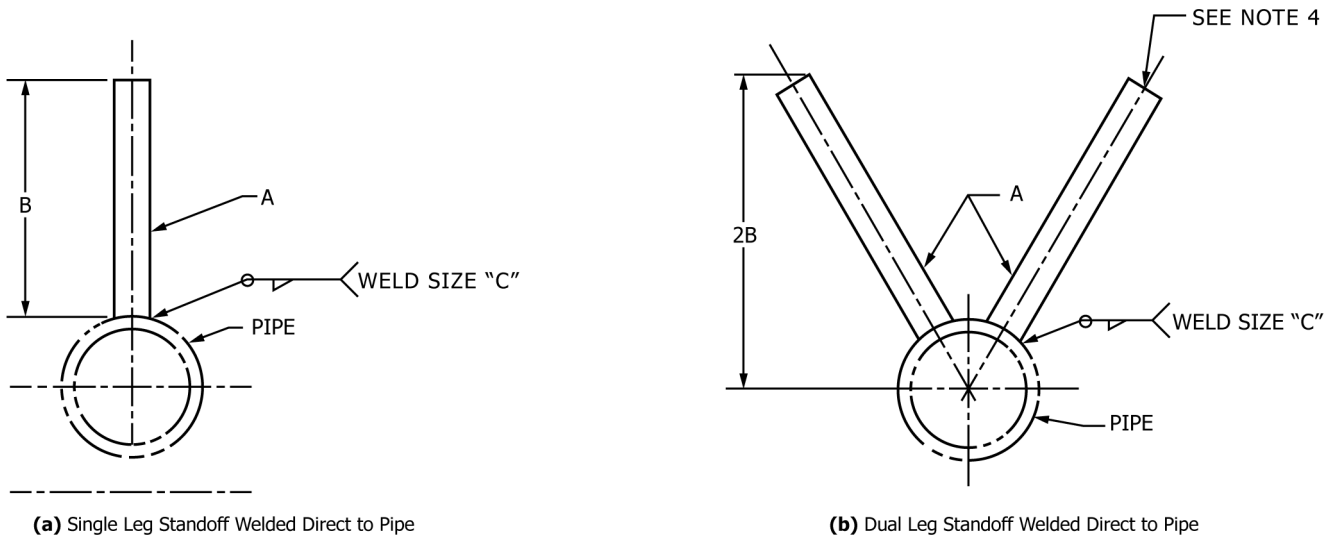

NOTE 1—For dimensions of hangers, see Table 5.

NOTE 2—These hangers are limited to use on normally dry ferrous piping systems, such as sounding tubes. Air escapes and plumbing drains with a wall thickness of 0.200 in. (5.1 mm) or more.

NOTE 3—These hangers should not be used where takedown is required or in the steering gear room, inner bottoms, fore peak, aft peak or deep tanks, or other high vibration or inaccessible areas.

NOTE 4—For Fig. 5(b), length of standoff legs may be unequal and angle of attachment may vary as required to suit conditions.

FIG. 5 Welded Hangers

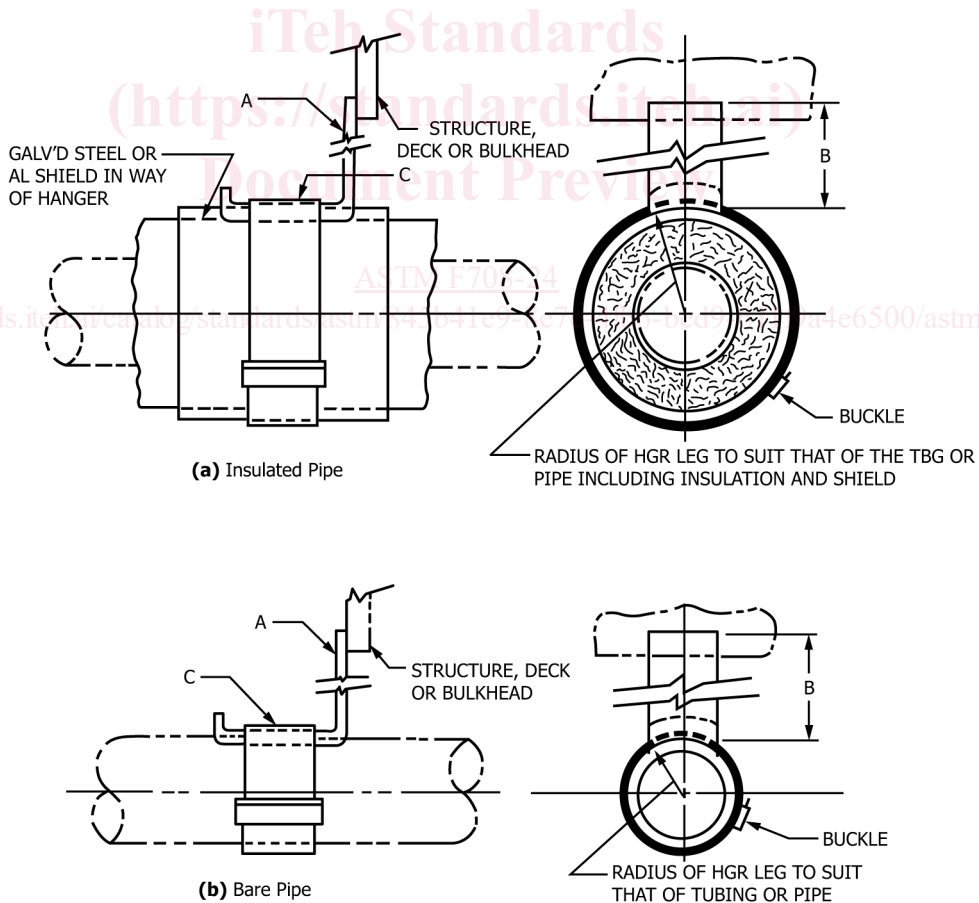

NOTE 1—For dimensions of hangers, see Table 6.

NOTE 2—These hangers are suitable for use in all locations, except tanks and areas exposed to the weather, and can be used lined or unlined.

FIG. 6 J-Band Type Hangers

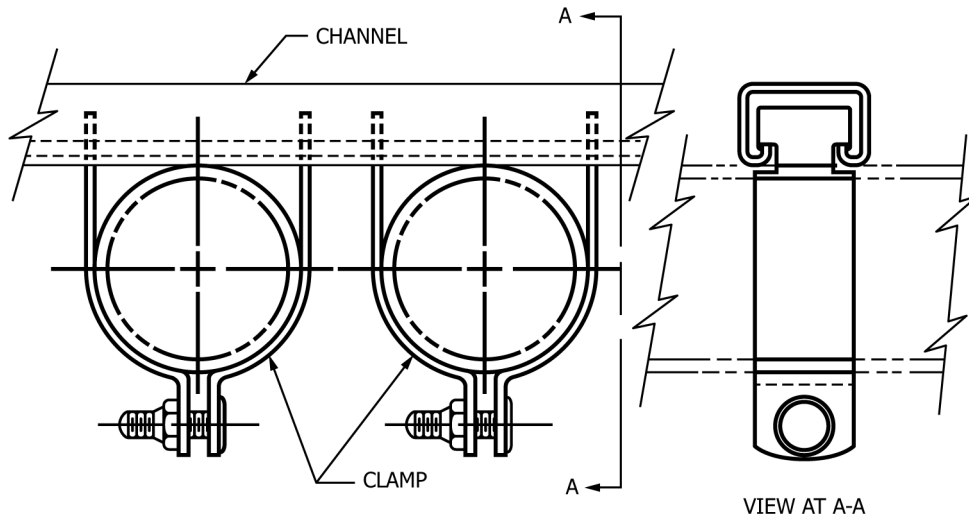

NOTE 1—These hangers are suitable for use in all locations, including tanks and areas exposed to the weather. When used in areas subject to high corrosion, such as salt water ballast tanks or weather decks, stainless steel hanger components shall be used.

NOTE 2—These hangers are suitable for supporting single or multiple runs of piping 2 in. (50.8 mm) or smaller.

FIG. 7 Clamp Hanger Assembled with Mounting Channel

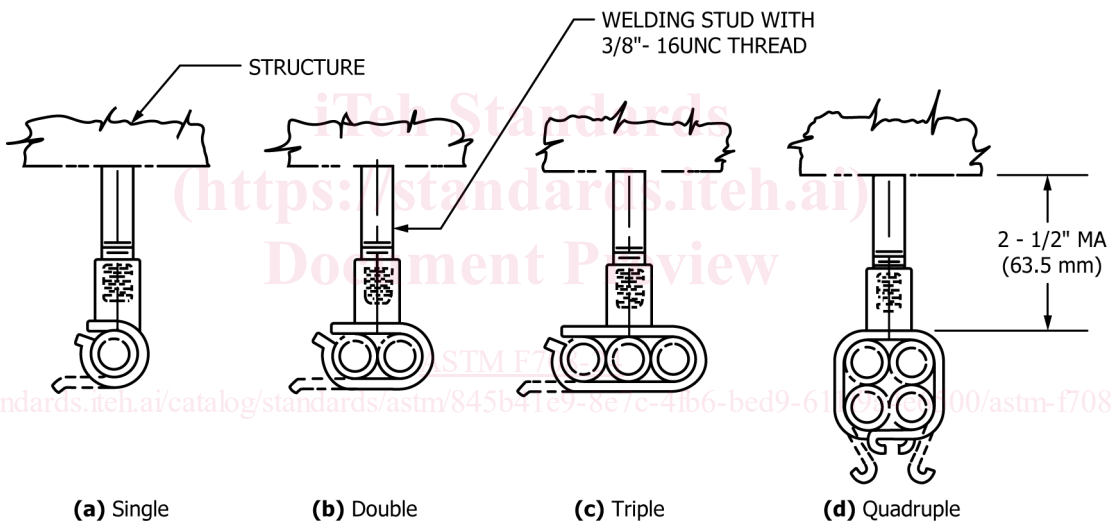

NOTE 1—These hangers are suitable for use in all locations, except tanks, and should be coated with neoprene or other similar material when used to support nonferrous tubing.

NOTE 2—These hangers are limited to use on tubing with an outside diameter of 1½ in. (28.6 mm) or smaller with a system operating temperature of 180 °F (82.2 °C) or less.

NOTE 3—Size and quantity of tubes may be varied provided they are arranged so as to be securely clamped.

FIG. 8 Crimp-On Weld Stud Hangers