



## Designation: C1266 – 17 (Reapproved 2024)

# Standard Test Method for Flow Characteristics of Preformed Tape Sealants<sup>1</sup>

This standard is issued under the fixed designation C1266; the number immediately following the designation indicates the year of original adoption or, in the case of revision, the year of last revision. A number in parentheses indicates the year of last reapproval. A superscript epsilon ( $\epsilon$ ) indicates an editorial change since the last revision or reapproval.

## 1. Scope

1.1 This test method describes a laboratory procedure for determining the flow characteristics of preformed tape sealants after a specified time, temperature, and load.

1.2 The values stated in SI units are to be regarded as the standard. The inch-pound units given in parentheses are provided for information purposes only.

1.3 The committee with jurisdiction of this specification is not aware of any similar specification within ISO or any other organization.

1.4 *This standard does not purport to address all of the safety concerns, if any, associated with its use. It is the responsibility of the user of this standard to establish appropriate safety, health, and environmental practices and determine the applicability of regulatory limitations prior to use.*

1.5 *This international standard was developed in accordance with internationally recognized principles on standardization established in the Decision on Principles for the Development of International Standards, Guides and Recommendations issued by the World Trade Organization Technical Barriers to Trade (TBT) Committee.*

## 2. Referenced Documents

2.1 *ASTM Standards:*<sup>2</sup>

**C717 Terminology of Building Seals and Sealants**

## 3. Terminology

3.1 *Definitions*—The definitions of the following terms used in this test method are found in Terminology **C717**: compound, seal, sealant, standard conditions, substrate and tape sealant.

## 4. Summary of Test Method

4.1 The tape sealant to be tested is rolled into spherical balls of equal weight. Four spherical balls are placed between two

<sup>1</sup> This test method is under the jurisdiction of ASTM Committee **C24** on Building Seals and Sealants and is the direct responsibility of Subcommittee **C24.20** on General Test Methods.

Current edition approved Jan. 1, 2024. Published January 2024. Originally approved in 1995. Last previous edition approved in 2017 as C1266–17. DOI: 10.1520/C1266-17R24.

<sup>2</sup> For referenced ASTM standards, visit the ASTM website, [www.astm.org](http://www.astm.org), or contact ASTM Customer Service at [service@astm.org](mailto:service@astm.org). For *Annual Book of ASTM Standards* volume information, refer to the standard's Document Summary page on the ASTM website.

aluminum plates, which are then compressed. A standard weight is placed on the test assembly for 1 h at room temperature. The height of the test assembly is measured to determine the rebound of the sample. The test assembly is then placed in an 88 °C (190 °F) oven with the standard weight on it. After 24 h the height of the test assembly is measured again to determine the flow of the sample.

## 5. Significance and Use

5.1 Tape sealants are tacky, deformable solids, which are used under compression between two or more surfaces of similar or dissimilar substrates in a variety of sealing applications. These tapes are normally supplied in a roll form with a release paper interlayer and are hand pressed against a fixed substrate. This procedure is designed to give an indication of the flow characteristics of a tape sealant under controlled temperature and aging conditions with a specified load.

## 6. Apparatus

6.1 *Aluminum Plates*, four, each 6.35 mm by 76.2 mm by 101.6 mm (0.25 by 3.00 by 4.00 in.).

6.2 *Lead Weights*, two, each 3.63 kg (8.0 lb) with dimensions large enough to cover the entire assembly, but not overhanging the assembly.

6.3 *Mechanical Convection Oven*, capable of maintaining a temperature of 88 °C  $\pm$  1 °C (190 °F  $\pm$  2 °F).

6.4 *Steel Spacers*, six, each 76.2 mm by 5.08 mm by 5.08 mm  $\pm$  0.05 mm (3.00 by 0.20 by 0.20  $\pm$  0.002 in.).

6.5 *Thickness Gage*, having a total capacity of at least 76.2 mm (3.00 in.) graduated in 0.025 mm (0.001 in.) divisions. The gage shall be equipped to provide a 57 g (2 oz) load over a minimum contact area of 6.35 mm (0.25 in.).

6.6 *Laboratory Press*, at room temperature, to compress the preformed sealant tape to the proper material thickness.

6.7 *Stop Watch*, to measure the timed intervals specified in the laboratory procedure.

6.8 *Laboratory Precision Balance* (capable of weighing to 0.1 mg) to measure the weight of the individual spherical balls of tape.

**7. Sampling**

7.1 Samples to be tested shall be taken from a fresh roll of tape sealant taken directly from a randomly selected commercial container as supplied by the manufacturer, after first removing and discarding approximately the first 0.61 (2 ft) of the roll.

**8. Test Assembly Preparation**

8.1 A total of two assemblies per tape are to be prepared.

8.1.1 Prepare a test assembly as follows:

8.1.1.1 Clean two aluminum plates with isopropyl alcohol (IPA) or other suitable solvent.

8.1.1.2 Using a marking pen, draw intersecting diagonals on one side of both metal plates. On each plate mark four points 32 mm (1.25 in.) from the intersection of the diagonals as shown in Fig. 1. These become the top surfaces.

8.1.1.3 Stack the plates, and using the thickness gage, measure the combined height of two aluminum plates at the intersection of the diagonals. Record as aluminum thickness (A).

8.1.1.4 Using a laboratory precision balance, weigh out four lengths of tape sealant to  $4.00\text{ g} \pm 0.05\text{ g}$  each. Each 4 g sample should be tightly rolled into a spherical ball without working the material excessively avoid entrapping air. Condition the four balls of tape for 1 h according at standard conditions before proceeding to 8.1.1.5.

8.1.1.5 Place each of the four—4 g spherical balls of tape sealant at quarter points (31.75 mm (1.25 in.) from the intersection of the diagonals) of the diagonals on one of the metal plates.

8.1.1.6 Place three steel spacers on the aluminum plate, one inboard between the spherical balls of tape and one spacer outboard of the balls of tape as shown in Fig. 2. The spacer bars should not contact the compound.

8.1.1.7 Position the other aluminum plate evenly over the spherical balls of tape sealant with the face marked with diagonals away from the tape sealant (Fig. 2).

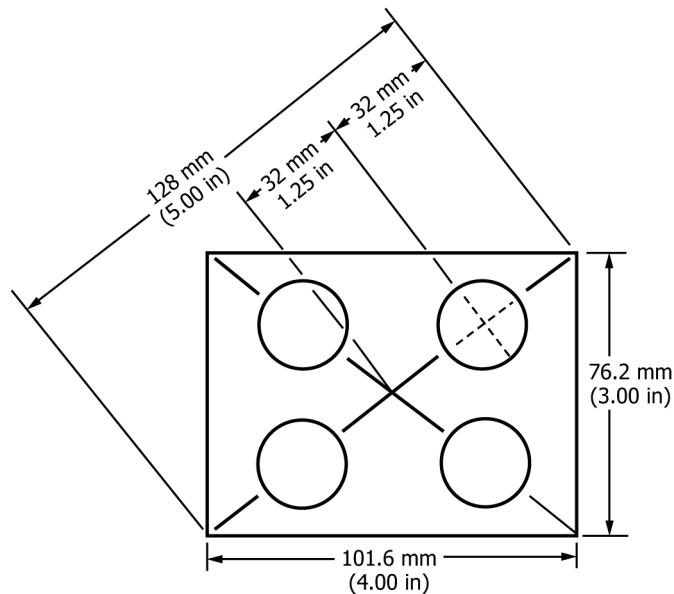

FIG. 1 Intersecting Diagonals on Metal Plate

8.1.1.8 Center the assembly on the base plate of the lab press at room temperature and compress firmly to the spacer bars, until the spacer bars cannot be moved by hand. Maintain this compression mode for 1 min. At the end of 1 min raise the press and remove the assembly taking care not to disturb it. Carefully remove the spacer bars (see Fig. 3).

**9. Conditioning**

9.1 Condition the test assemblies at standard conditions for 1 h.

**10. Procedure**

10.1 After 1 h at standard conditions, using the thickness gage, measure the thickness of each test assembly at the intersection of the diagonals to 0.025 mm (0.001 in.). Record this value as (B). For each assembly calculate the rebound height of the tape sealant as follows:

$$R = B - A \tag{1}$$

where:

R = rebound height, mm (in.),

B = combined aluminum and tape sealant thickness after time specified, mm (in.), and

A = combined aluminum thickness as determined in 8.1.1.3, mm (in.).

10.2 Place both test assemblies in a mechanical convection oven maintained at  $88\text{ }^\circ\text{C} \pm 1\text{ }^\circ\text{C}$  ( $190\text{ }^\circ\text{F} \pm 2\text{ }^\circ\text{F}$ ). Position a 3.63 kg (8.0 lb) weight on top of each test assembly. Center the weight on each test assembly, avoiding sliding of the weight during the test. Expose the test specimens at  $88\text{ }^\circ\text{C} \pm 1\text{ }^\circ\text{C}$  ( $190\text{ }^\circ\text{F} \pm 2\text{ }^\circ\text{F}$ ) for 24 h.

10.3 After 24 h, remove the test assemblies from the oven, remove the weight and allow the test assemblies to cool at standard conditions for 15 min.

10.4 Measure the thickness of each test assembly as described in 10.1 and record as value (C).

**11. Calculation**

11.1 For each assembly calculate the flow of the tape as follows:

$$F = B - C \tag{2}$$

where:

F = flow, mm (in.),

B = combined aluminum and tape sealant thickness after time specified (see 10.1), mm (in.), and

C = combined aluminum and tape sealant thickness after exposure (see 10.4), mm (in.).

11.2 For each assembly calculate the residual height of the tape as follows:

$$H = R - F \tag{3}$$

where:

H = residual height after exposure, mm (in.),

R = rebound height (see 10.1), mm (in.), and

F = flow (see 11.1), mm (in.).