



Designation: C1803/C1803M – 23

# Standard Guide for Abrasion Resistance of Mortar Surfaces Using a Rotary Platform Abraser<sup>1</sup>

This standard is issued under the fixed designation C1803/C1803M; the number immediately following the designation indicates the year of original adoption or, in the case of revision, the year of last revision. A number in parentheses indicates the year of last reapproval. A superscript epsilon ( $\epsilon$ ) indicates an editorial change since the last revision or reapproval.

## 1. Scope\*

1.1 This guide is intended to assist in establishing procedures for determining the relative abrasion resistance of treated or untreated mortar surfaces.

1.2 This guide utilizes the rotary platform abraser, which generates a combination of rolling and rubbing to cause wear to the specimen surface. Wear can be quantified as cycles to a specific end-point. Other commonly used evaluations are presented in [Appendix X1](#) and include mass loss, wear index, volume loss, or depth of wear.

1.3 The values stated either in SI units or inch-pound units are to be regarded separately as standard. The values stated in each system are not necessarily exact equivalents; therefore, to ensure conformance with the standard, each system shall be used independently of the other, and values from the two systems shall not be combined. Some values have only SI units because the inch-pound equivalents are not used in practice.

NOTE 1—Other procedures used to measure abrasion resistance of concrete surfaces include Test Methods [C418](#), [C779/C779M](#), [C944/C944M](#), and [C1138M](#). Other methods that reference the rotary platform abraser and may be of interest include Specification [C744](#) and Test Methods [C1353](#), [D4060](#) and [F510](#).

1.4 The text of this standard refers to notes and footnotes that provide explanatory material. These notes and footnotes (excluding those in tables and figures) shall not be considered as requirements of this standard.

1.5 *This standard does not purport to address all of the safety concerns, if any, associated with its use. It is the responsibility of the user of this standard to establish appropriate safety, health, and environmental practices and determine the applicability of regulatory limitations prior to use.*

1.6 *This international standard was developed in accordance with internationally recognized principles on standardization established in the Decision on Principles for the Development of International Standards, Guides and Recom-*

*mendations issued by the World Trade Organization Technical Barriers to Trade (TBT) Committee.*

## 2. Referenced Documents

### 2.1 ASTM Standards:<sup>2</sup>

- [C33/C33M Specification for Concrete Aggregates](#)
- [C109/C109M Test Method for Compressive Strength of Hydraulic Cement Mortars \(Using 2-in. or \[50 mm\] Cube Specimens\)](#)
- [C125 Terminology Relating to Concrete and Concrete Aggregates](#)
- [C418 Test Method for Abrasion Resistance of Concrete by Sandblasting](#)
- [C744 Specification for Prefaced Concrete and Calcium Silicate Masonry Units](#)
- [C779/C779M Test Method for Abrasion Resistance of Horizontal Concrete Surfaces](#)
- [C944/C944M Test Method for Abrasion Resistance of Concrete or Mortar Surfaces by the Rotating-Cutter Method](#)
- [C1138M Test Method for Abrasion Resistance of Concrete \(Underwater Method\)](#)
- [C1353 Test Method for Abrasion Resistance of Dimension Stone Subjected to Foot Traffic Using a Rotary Platform Abraser](#)
- [D4060 Test Method for Abrasion Resistance of Organic Coatings by the Taber Abraser](#)
- [D6532 Test Method for Evaluation of the Effect of Clear Water Repellent Treatments on Water Absorption of Hydraulic Cement Mortar Specimens](#)
- [F510 Test Method for Resistance to Abrasion of Resilient Floor Coverings Using an Abrader with a Grit Feed Method](#)
- [G195 Guide for Conducting Wear Tests Using a Rotary Platform Abraser](#)

## 3. Terminology

### 3.1 Definitions:

<sup>1</sup> This guide is under the jurisdiction of ASTM Committee C09 on Concrete and Concrete Aggregates and is the direct responsibility of Subcommittee C09.62 on Abrasion Testing.

Current edition approved Dec. 1, 2023. Published January 2024. Originally published in 2015. Last previous edition approved in 2020 as C1803–20. DOI: 10.1520/C1803-23.

<sup>2</sup> For referenced ASTM standards, visit the ASTM website, [www.astm.org](http://www.astm.org), or contact ASTM Customer Service at [service@astm.org](mailto:service@astm.org). For *Annual Book of ASTM Standards* volume information, refer to the standard's Document Summary page on the ASTM website.

\*A Summary of Changes section appears at the end of this standard

3.1.1 For definitions of terms used in this guide, refer to Terminology C125.

3.2 Definitions of Terms Specific to This Guide:

3.2.1 *abraser, n*—an instrument designed to determine the resistance of surfaces to abrasion, also referred to as an abrader.

3.2.1.1 *Discussion*—For the rotary platform abramer used in this guide, abrasion is produced by a combined action of rolling and rubbing.

3.2.2 *abrasion cycle, n*—one complete rotation of the specimen turntable platform.

3.2.3 *resurface, v*—to refresh the abrading function of the contact surface of an abrasive wheel.

4. Summary of Guide

4.1 Abrasion resistance of a treated or untreated mortar surface is determined by subjecting a specimen to rotary rubbing action under controlled conditions of pressure and abrasive action. The test specimen, mounted on a turntable platform, turns on a vertical axis, against the sliding rotation of two abrasive wheels. One abrasive wheel rubs the specimen outward toward the periphery and the other, inward toward the center while a vacuum system removes wear debris generated during the test. The resulting abrasion marks form a pattern of crossed arcs in a circular wear path that covers an area of approximately 30.0 cm<sup>2</sup> [4.7 in.<sup>2</sup>]. Unless otherwise agreed upon between the interested parties, specimens are subjected to 200 cycles or 1000 cycles with the abrasive wheels being cleaned with a stiff bristle brush after every 50 cycles. The effectiveness of a treatment involves comparing treated specimens to untreated control specimens using the same mortar, method of preparation, and curing regimen. Resistance to

abrasion is evaluated by various means, which are described in Section 11 and Appendix X1.

5. Significance and Use

5.1 Wear on mortar surfaces can be generated by a number of factors including skidding, scraping or sliding of objects on the surface, foot and tire traffic. This guide provides a means to quantify the abrasion resistance of treated or untreated mortars and other similar products.

5.1.1 This guide can be used to determine the effectiveness of fluid applied hardeners, densifiers and sealers by comparison with untreated control specimens.

5.1.2 This guide can be used with other test methods to determine the effectiveness of surface treatments after abrasion. For example, Test Method D6532 can be used to evaluate the effectiveness of clear water repellents on hydraulic cement mortar specimens based on water absorption after water soaking, by testing the specimen prior to abrasion and after the specimen has been subjected to abrasion.

5.2 This guide may be useful for acceptance testing of a mortar surface, and it can be used to evaluate the effects of processing variables such as substrate preparation before treatment, surface texture, treatment application variables, and curing regimen.

5.3 Results may be used to correlate with in-place performance, for comparative rating of the performance of alternative materials, or for comparison among treated and untreated surfaces. The resistance of material surfaces to abrasion, as measured on a testing machine in the laboratory, is generally only one of several factors contributing to wear performance as experienced in the actual use of the material.

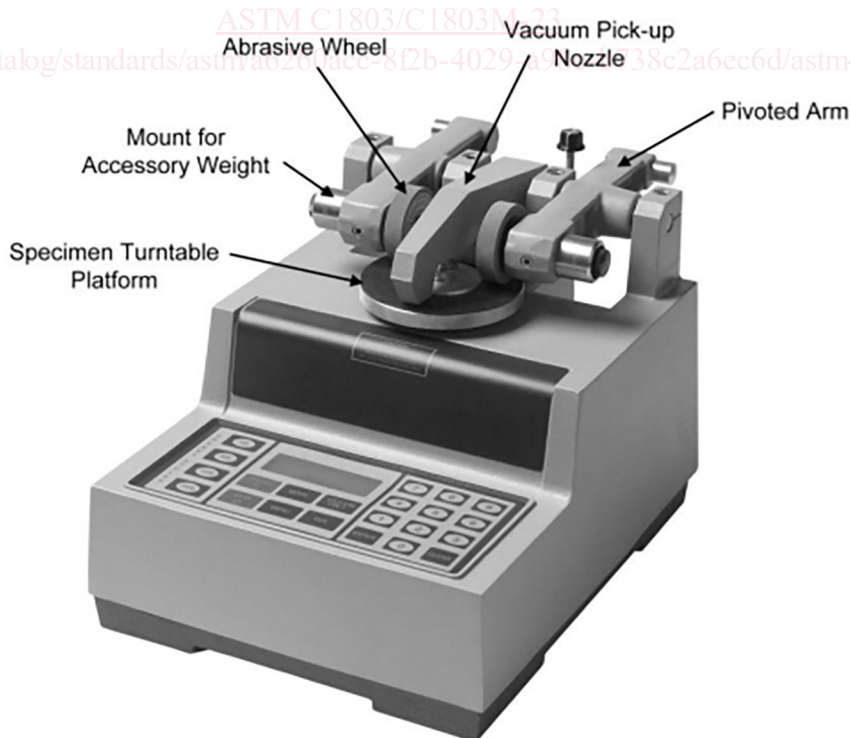

FIG. 1 Rotary Platform Abraser

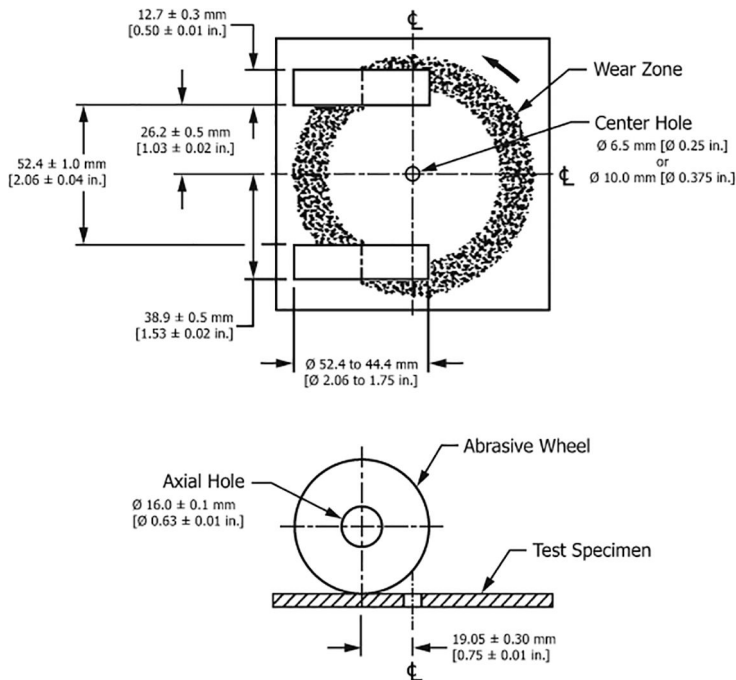

FIG. 2 Arrangement of Rotary Platform Abraser Test Set-up

Other factors may need to be considered in any calculation of predicted life from specific abrasion data.

5.4 The resistance of mortar to abrasion may be affected by factors including test conditions, type of abradant, pressure between the specimen and abradant, selection of mortar-making materials (mixture proportions, curing and finishing procedures), and type, kind, or amount of treatment materials.

5.5 Abrasion tests utilizing the rotary platform abramer may be subject to variation due to changes in the abradant during the course of specific tests. Depending on abradant type and test specimen, the abrasive wheel contact surface may become clogged due to the adhesion of wear debris generated during the test to the surface of the abrasive wheel. To provide more consistent results, the abrasive wheels should be cleaned and resurfaced at regularly defined intervals.

## 6. Apparatus

6.1 *Rotary Platform Abraser*<sup>3</sup>, as described in Guide G195 (see Figs. 1 and 2).

6.1.1 *Extension Nut* (optional), such as model S-21<sup>3</sup> for securing specimens that are 6.5 mm to 13.0 mm [0.25 in. to 0.5 in.] in thickness.

6.1.2 *Specimen Holder* (optional), including drive pins and sliding mounts in place of the centrally located threaded post and nut, may be used to eliminate the need for a center hole in the test specimen. Models E140-19<sup>3</sup> or SH-19<sup>3</sup> have been found satisfactory for this purpose.

6.2 *Abrasive Wheels*<sup>3</sup>, attached to the free end of the pivoted arms and able to rotate freely about horizontal spindles. The abrasive wheels shall be either vitrified, such as H-22, or

resilient based, consisting of hard particles embedded in a binder material. The wheels shall be 12.7 mm ± 0.3 mm [0.50 in. ± 0.01 in.] thick, include an axial hole 16.0 mm ± 0.1 mm [0.63 in. ± 0.01 in.] and have an external diameter of 52.4 mm to 44.4 mm [2.06 in. to 1.75 in.]. The contact surface of the wheels shall be 90° to the side. When not in use, store the wheels according to the manufacturer's recommendations.

6.3 *Wheel Refacer*, with a diamond tool for resurfacing vitrified wheels or correcting out of round wheels.

6.4 *Stiff Bristle Nylon Brush*, to remove debris from the abrasive wheels during testing and loose particles from the surface of the specimen after testing.

6.5 *Balance (optional)*, capable of weighing specimens with a resolution of 0.01 g.

## 7. Specimen Preparation

7.1 At least three replicate specimens shall comprise a test result.

7.1.1 For evaluating the effectiveness of a treatment, at least three replicate specimens for each treatment shall be compared with at least three untreated control specimens using the same mortar, method of preparation, and curing regimen.

7.2 *Materials*—It is the intent of this guide to allow for the abrasion testing of mortars, provided both top and bottom surfaces of the specimen are plane and parallel.

7.2.1 The methods of specimen fabrication and curing regimens shall be agreed to by the interested parties.

7.2.2 A standard mortar, as agreed upon by the interested parties, shall be used if a treatment is to be applied to the mortar surface. Only fine aggregate as defined by Specification C33/C33M is to be used, unless otherwise agreed to by the interested parties.

<sup>3</sup> The sole source of supply of the apparatus known to the committee at this time is Taber Industries, 455 Bryant Street, North Tonawanda, NY 14120.