



Designation: C900 – 23

# Standard Test Method for Pullout Strength of Hardened Concrete<sup>1</sup>

This standard is issued under the fixed designation C900; the number immediately following the designation indicates the year of original adoption or, in the case of revision, the year of last revision. A number in parentheses indicates the year of last reappraisal. A superscript epsilon ( $\epsilon$ ) indicates an editorial change since the last revision or reappraisal.

## 1. Scope\*

1.1 This test method covers determination of the pullout strength of hardened concrete by measuring the force required to pull an embedded metal insert and the attached concrete fragment from a concrete test specimen or structure. The insert is either cast into fresh concrete or installed in hardened concrete. This test method does not provide statistical procedures to estimate other strength properties.

1.2 The values stated in SI units are to be regarded as the standard. No other units of measurement are included in this test method.

1.3 The text of this test method refers to notes and footnotes that provide explanatory material. These notes and footnotes (excluding those in tables and figures) shall not be considered as requirements of this test method.

1.4 *This standard does not purport to address all of the safety concerns, if any, associated with its use. It is the responsibility of the user of this standard to establish appropriate safety, health, and environmental practices and determine the applicability of regulatory limitations prior to use. (Warning—Fresh hydraulic cementitious mixtures are caustic and may cause chemical burns to skin and tissue upon prolonged exposure.)*<sup>2</sup>

1.5 *This international standard was developed in accordance with internationally recognized principles on standardization established in the Decision on Principles for the Development of International Standards, Guides and Recommendations issued by the World Trade Organization Technical Barriers to Trade (TBT) Committee.*

## 2. Referenced Documents

### 2.1 ASTM Standards:<sup>3</sup>

<sup>1</sup> This test method is under the jurisdiction of ASTM Committee C09 on Concrete and Concrete Aggregates and is the direct responsibility of Subcommittee C09.64 on Nondestructive and In-Place Testing.

Current edition approved Dec. 15, 2023. Published January 2024. Originally approved in 1978. Last previous edition approved in 2019 as C900 – 19. DOI: 10.1520/C0900-23.

<sup>2</sup> Section on Safety Precautions, Manual of Aggregate and Concrete Testing, *Annual Book of ASTM Standards*, Vol 04.02.

<sup>3</sup> For referenced ASTM standards, visit the ASTM website, [www.astm.org](http://www.astm.org), or contact ASTM Customer Service at [service@astm.org](mailto:service@astm.org). For *Annual Book of ASTM Standards* volume information, refer to the standard's Document Summary page on the ASTM website.

C125 Terminology Relating to Concrete and Concrete Aggregates

C670 Practice for Preparing Precision and Bias Statements for Test Methods for Construction Materials

E4 Practices for Force Calibration and Verification of Testing Machines

E74 Practices for Calibration and Verification for Force-Measuring Instruments

## 3. Terminology

### 3.1 Definitions:

3.1.1 For definitions of terms used in this method, refer to Terminology C125.

## 4. Summary of Test Method

4.1 A metal insert is either cast into fresh concrete or installed into hardened concrete. When a measure of the in-place pullout strength is desired, the insert is pulled by means of a jack reacting against a bearing ring. The pullout strength is determined by measuring the maximum force required to pull the insert from the concrete mass. Alternatively, the insert is loaded to a specified load to verify whether a minimum level of in-place pullout strength has been attained.

## 5. Significance and Use

5.1 For a given test apparatus, pullout strengths can be related to compressive strength test results. Such strength relationships are affected by the configuration of the embedded insert, bearing ring dimensions, depth of embedment, and the type of aggregate (lightweight or normal weight). Before use, the relationship must be established experimentally for each test system using a range of concrete mixtures or the specific concrete mixtures to be used in the project. Such relationships are more reliable if both pullout test specimens and compressive strength test specimens are of similar size, consolidated to similar density, and cured under similar conditions.

NOTE 1—Published reports (1-19)<sup>4</sup> by different researchers present their experiences in the use of pullout test equipment. Refer to ACI PRC-228.1 (14) for guidance on establishing a strength relationship and interpreting test results.

<sup>4</sup> The boldface numbers refer to the list of references at the end of this test method.

\*A Summary of Changes section appears at the end of this standard

5.2 If a strength relationship has been accepted by the specifier of tests, pullout tests are used to estimate the in-place strength of concrete to establish whether it has reached a specified level so that, for example:

- (1) post-tensioning may proceed;
- (2) forms and shores may be removed;
- (3) structure may be placed into service; or
- (4) winter protection and curing may be terminated.

In addition, post-installed pullout tests may be used to estimate the strength of concrete in existing construction.

5.3 In planning pullout tests and analyzing test results, consideration should be given to the normally expected decrease of concrete strength with increasing height within a given concrete placement in a structural element.

5.4 The measured pullout strength is indicative of the strength of concrete within the region represented by the conic frustum defined by the insert head and bearing ring. For typical surface installations, pullout strengths are indicative of the quality of the outer zone of concrete members and can be of benefit in evaluating the cover zone of reinforced concrete members.

5.5 Cast-in-place inserts require that their locations in the structure be planned in advance of concrete placement. Post-installed inserts can be placed at any desired location in the structure provided the requirements of 7.1 are satisfied.

5.6 This test method is not applicable to other types of post-installed tests that, if tested to failure, do not involve the same failure mechanism and do not produce the same conic frustum as for the cast-in-place test described in this test method (16).

## 6. Apparatus

6.1 The apparatus requires three basic sub-systems: a pullout insert, a loading system, and a load-measuring system (Note 2). For post-installed inserts, additional equipment includes a core drill, a planing tool to prepare a flat bearing surface, a grinding tool to undercut a groove to engage the insert, and an expansion tool to expand the insert into the groove.

NOTE 2—A center-pull hydraulic jack with a pressure gauge that has been standardized according to Annex A1 and that reacts against a bearing ring has been used as a satisfactory loading system.

6.1.1 Cast-in-place inserts shall be made of metal that does not react with the constituents of the concrete. The insert shall consist of a cylindrical head and a shaft to fix embedment depth. The shaft shall be attached firmly to the center of the head (see Fig. 1). The insert shaft shall be threaded to the insert head so that it can be removed and replaced by a stronger shaft to pullout the insert, or it shall be an integral part of the insert and function as the pullout shaft. Metal components of cast-in-place inserts and attachment hardware shall be of similar material to prevent galvanic corrosion. Post-installed inserts shall be designed so that they will fit into the core holes, and can be expanded subsequently to fit into the grooves that have been undercut at the required depth (see Fig. 2).

NOTE 3—A successful post-installed system uses a split ring that is

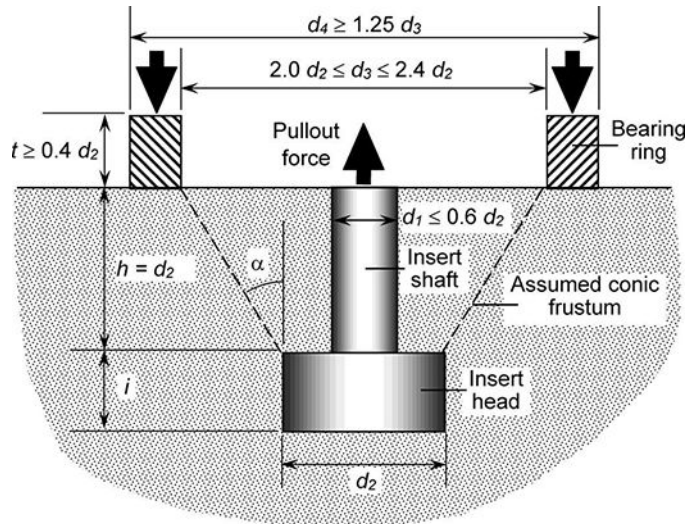

FIG. 1 Schematic Cross Sectional View of Cast-in-Place Pullout Test

coiled to fit into the core hole and then expanded into the groove.

6.1.2 The loading system shall consist of a bearing ring to be placed against the hardened concrete surface (see Figs. 1 and 2) and a tensile loading apparatus, with a load-measuring device that can be attached to the pullout shaft.

6.1.3 The test apparatus shall include centering features such that the bearing ring is concentric with the insert, and that the applied load is axial to the pullout shaft, perpendicular to the bearing ring, and uniform on the bearing ring.

6.2 Equipment dimensions shall be determined as follows (see Fig. 1):

6.2.1 The diameter of the insert head ( $d_2$ ) is the basis for defining the test geometry. The thickness of the insert head and the yield strength of the metal shall be sufficient to prevent yielding of the insert during test. The sides of the insert head shall have a surface similar to a regular matte finish of cold-rolled steel (see Note 5). The insert head diameter shall be at least  $\frac{2}{3}$  of the nominal maximum size of aggregate.

NOTE 4—Typical diameters of commercially-available inserts are 25 and 30 mm, but larger diameters have been used (1, 3). Appendix X1 provides the equation to calculate the nominal tensile stress on the assumed conic frustum shown in Fig. 1. This nominal stress can be used to compare pullout strengths obtained with test systems having different insert diameters. Tests (15) have shown that nominal maximum aggregate sizes up to 1.5 times the head diameter do not have significant effects on the strength relationships. Larger aggregate sizes may result in increased scatter of the test results because the large particles can interfere with pullout of the conic frustum.

NOTE 5—Cast-in-place inserts may be coated with a release agent to reduce bonding with the concrete, and they may be tapered to reduce side friction during testing. The insert head should be provided with the means, such as a notch, to prevent rotation in the concrete if the insert shaft has to be removed before performing the test. As a further precaution against rotation of the insert head, all threaded hardware should be checked before installation to confirm that it is free-turning and can be removed easily. A thread-lock compound is recommended to prevent loosening of the insert head from the shaft during installation and during vibration of the surrounding concrete.

6.2.2 For cast-in-place inserts, the distance from the insert head to the concrete surface ( $h$ ) shall equal the diameter of the



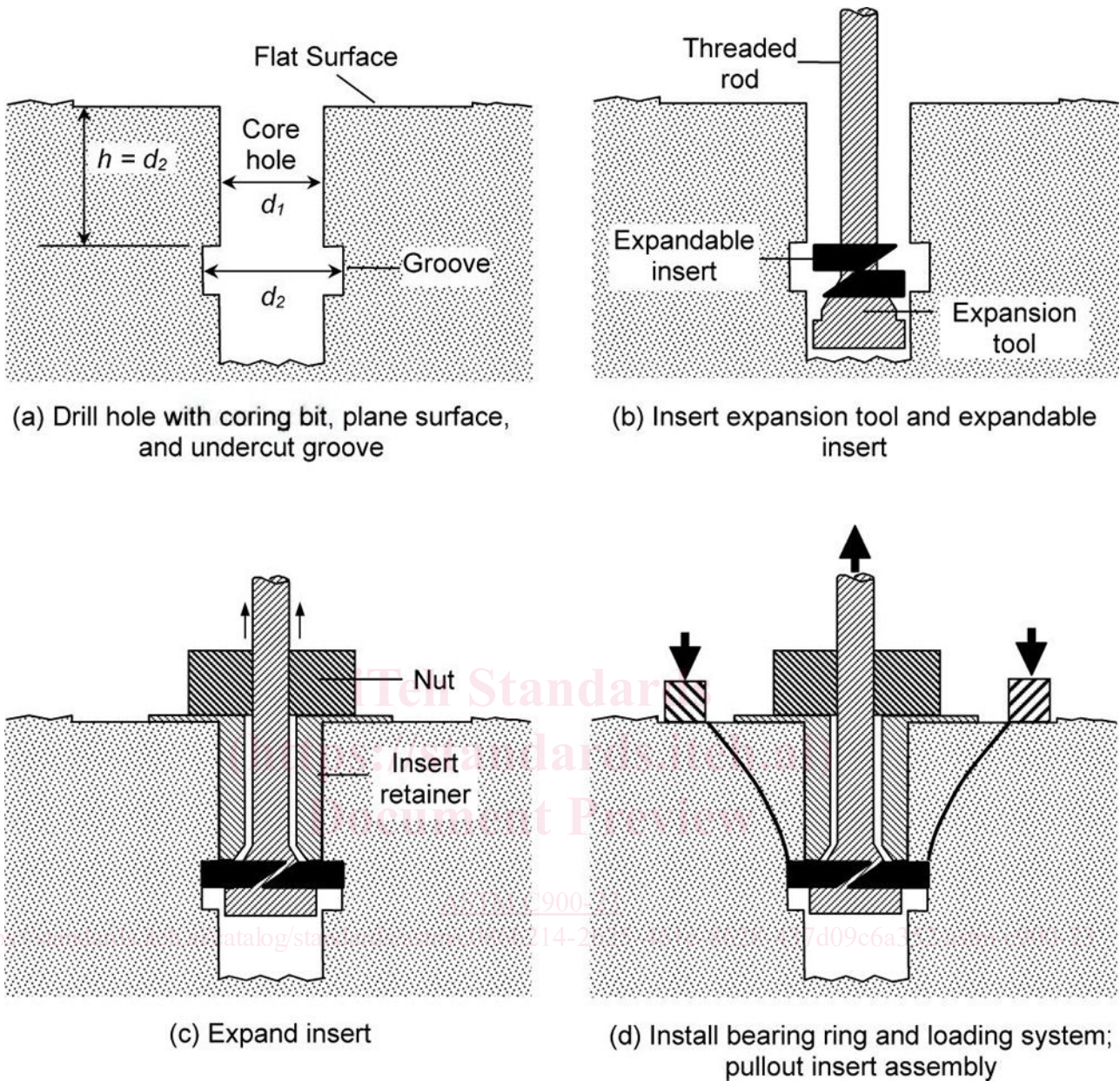

FIG. 2 Schematic of Procedure for Post-Installed Pullout Test

insert head ( $d_2$ ). The diameter of the insert shaft at the head ( $d_1$ ) shall not exceed  $0.60 d_2$ .

6.2.3 For post-installed inserts, the groove to accept the expandable insert shall be cut so that the distance between the bearing surface of the groove and concrete surface equals the insert diameter after expansion ( $d_2$ ). The difference between the diameters of the undercut groove ( $d_2$ ) and the core hole ( $d_1$ ) shall be sufficient to prevent localized failure and result in the extraction of a conic frustum of concrete during the test (see Note 6). The expanded insert shall bear uniformly over the bearing area of the groove.

NOTE 6—A core hole diameter of 18 mm and an undercut groove diameter of 25 mm have been used successfully.

6.2.4 The bearing ring shall have an inside diameter ( $d_3$ ) of 2.0 to 2.4 times the insert head diameter ( $d_2$ ), and shall have an

outside diameter ( $d_4$ ) of at least 1.25 times the inside diameter. The thickness of the bearing ring ( $t$ ) shall be at least 0.4 times the pullout insert head diameter. For a given test system, the same bearing ring dimensions shall be used.

6.2.5 Tolerances for dimensions of the pullout test inserts, bearing ring and embedment depth shall be  $\pm 2\%$  within a given system.

NOTE 7—The limits for dimensions and configurations for pullout test inserts and apparatus are intended to accommodate various systems.

6.2.6 The loading apparatus shall be capable of applying load continuously and have sufficient capacity to provide the loading rate prescribed in 8.4.

NOTE 8—Hydraulic pumps that apply load intermittently will increase the variability of test results.

6.2.7 The gauge to measure pullout force is permitted to be of the analog or digital type. Analog gauges shall be designed so that the pullout force can be estimated to the nearest 0.5 kN. Digital gauges shall display the pullout force to the nearest 0.1 kN.

6.2.8 The force gauge shall have a means to preserve the maximum value of the load during a test.

6.2.9 Pullout apparatus shall be standardized in accordance with Annex A1 at least once a year and after all repairs. Standardize the pullout apparatus using a testing machine verified in accordance with Practices E4 or using a Class A load cell as defined in Practice E74. The indicated pullout force based on the developed relationship shall be within  $\pm 2\%$  of the force measured by the testing machine or load cell.

### 7. Sampling

7.1 *Clear Spacing* (see Fig. 3)—The clear spacing between insert heads shall be at least seven times the insert head diameter. Clear spacing between the insert heads and the edges of the concrete shall be at least 3.5 times the head diameter. If reinforcement cover is less than 1.5 times the head diameter, inserts shall be located so that the clear distance between reinforcement and the inner diameter of the bearing ring is at least the nominal maximum size of aggregate. These clearance requirements also apply to test specimens used to develop strength relationships.

NOTE 9—A reinforcement locator is recommended to assist in avoiding reinforcement when planning the locations of post-installed tests. Follow the manufacturer’s instructions for proper operation of such devices.

7.2 *Number of Tests*—If pullout test results are used to assess the in-place strength to allow the start of critical construction operations, such as formwork removal or application of post tensioning, at least five individual pullout tests shall be performed as follows:

7.2.1 For every 115 m<sup>3</sup>, or a fraction thereof, of a given placement; or

7.2.2 For every 470 m<sup>2</sup>, or a fraction thereof, of the surface area of one face of a slab or wall.

NOTE 10—More than the minimum number of inserts should be provided in case a test result is not valid or testing begins before adequate strength has developed.

7.2.3 If pullout tests are used for other purposes, the number of tests shall be determined by the specifier of the test.

7.3 *Test Locations*—Inserts shall be located in those portions of the structure that are critical in terms of exposure conditions and structural requirements.

### 8. Procedure

#### 8.1 Cast-in-Place Inserts:

8.1.1 Attach the pullout inserts to the forms using bolts or by other methods that firmly secure the insert in its proper location before concrete placement. All inserts shall be embedded to the same depth. The axis of each shaft shall be perpendicular to the formed surface.

8.1.2 Alternatively, if instructed by the specifier of tests, manually place inserts into unformed horizontal concrete surfaces. The inserts shall be embedded into the fresh concrete by means that result in a uniform embedment depth and a surface to support the bearing ring that is plane and perpendicular to the axis of the insert shaft. Installation of inserts shall be performed or supervised by personnel trained by the manufacturer or manufacturer’s representative.

NOTE 11—Experience indicates that pullout strengths are of lower value and more variable for manually-placed surface inserts than for inserts attached to formwork (12).

8.1.3 When pullout strength of the concrete is to be measured, remove all hardware used for securing the pullout inserts in position. Before mounting the loading system, remove any debris or surface abnormalities that interfere with uniform contact of the bearing ring.

#### 8.2 Post-Installed Inserts:

8.2.1 The selected test location shall provide a suitable working surface for drilling the core. Drill a core hole using the coring bit provided by the manufacturer. The core depth shall be in accordance with the manufacturer’s instructions. Break

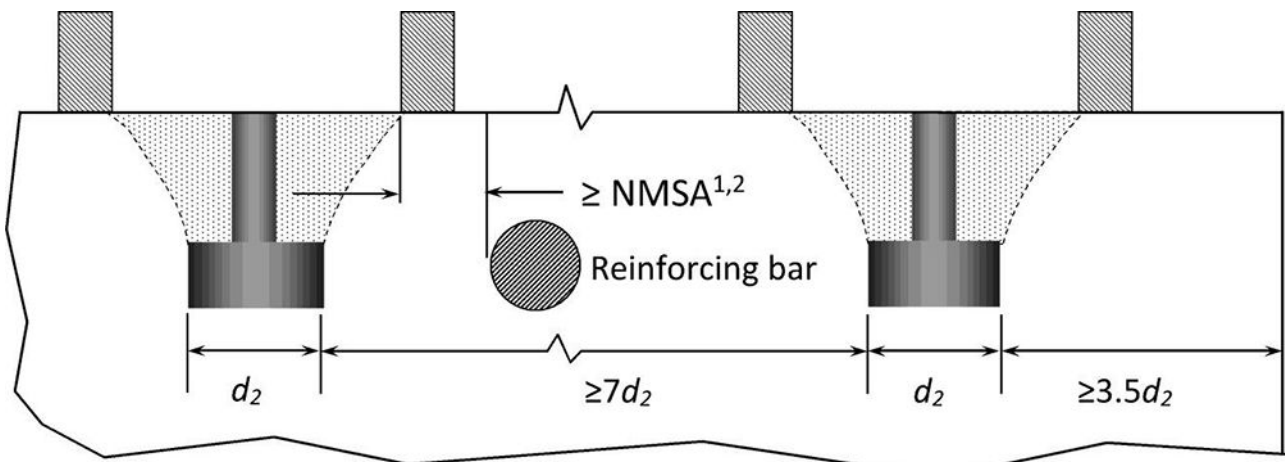

<sup>1</sup>NMSA = Nominal maximum size of aggregate.

<sup>2</sup>Applies if reinforcement cover depth is less than  $1.5d_2$ .

FIG. 3 Clearance Requirements for Cast-In-Place and Post-Installed Pullout Tests



off the core to provide a reference hole for subsequent operations. The use of an impact drill is not permitted.

8.2.2 Use a surface planing tool in accordance with the manufacturer's instructions to prepare a flat surface that is perpendicular to the axis of the core hole.

8.2.3 Use the grinding tool in accordance with the manufacturer's instructions to undercut a groove of the correct diameter and at the correct depth in the core hole. The groove shall be concentric with the core hole.

NOTE 12—To control the accuracy of these operations, a support system should be used to maintain the apparatus in the proper position during these steps.

8.2.4 If water is used as a coolant, remove free-standing water from the hole at the completion of the drilling, planing, and undercutting operations. Protect the hole from ingress of additional water until completion of the test.

NOTE 13—Penetration of water into the failure zone could affect the measured pullout strength.

8.2.5 Use the expansion tool to position the expandable insert into the core hole and expand the insert to its proper size within the groove in accordance with the manufacturer's instructions.

8.3 *Bearing Ring*—Place the bearing ring concentric with the pullout insert shaft and connect the pullout shaft to the loading system. Remove slack in the pullout assembly in accordance with the manufacturer's instructions so that the bearing ring is snug against the concrete surface.

8.4 *Loading Rate*—Apply load at a uniform rate so that the nominal tensile stress on the assumed conical fracture surface increases at a rate of 70 kPa/s  $\pm$  30 kPa/s (NOTE 14). If the insert is to be tested to failure, load at the specified uniform rate until the maximum load is attained. Record the maximum load to the nearest 0.5 kN for analog gauges and to the nearest 0.1 kN for digital gauges. If requested by the specifier of tests, extract the conic frustum in accordance with the manufacturer's instructions. If the insert is to be loaded only to a specified load to verify whether a minimum in-place pullout strength has been attained, load at the specified uniform rate until the specified pullout load is reached. Maintain the specified load for at least 10 s.

NOTE 14—The loading rate is specified in terms of a nominal stress rate to accommodate different sizes of pullout test systems. See Appendix X1 for the formula relating the nominal tensile stress on the assumed conic frustum and the pullout load. For a commonly used pullout test system in which  $d_2 = 25$  mm and  $d_3 = 55$  mm, the specified stress rate corresponds to a loading rate of approximately 0.5 kN/s  $\pm$  0.2 kN/s. If this system is used, the ranges of the times to complete a test for different anticipated ultimate pullout loads would be as follows:

Anticipated Pullout Load, kN	Minimum Time, s	Maximum Time, s
10	14	33
20	29	67
30	43	100
40	57	133
50	71	167
60	86	200
70	100	233
80	114	267
90	129	300
100	143	333

8.4.1 Do not test frozen concrete.

8.5 *Rejection*—Reject a test result if one or more of the following conditions are encountered:

8.5.1 The large end of the conic frustum is not a complete circle of the same diameter as the inside diameter of the bearing ring;

8.5.2 The distance from the surface to the insert head ( $h$  in Fig. 1 or Fig. 2) is not equal to the insert diameter;

8.5.3 The diameter of the groove in a post-installed test is not equal to the manufacturer's design value;

8.5.4 The expanded insert diameter in a post-installed test is not equal to the manufacturer's design value; or,

8.5.5 A reinforcing bar is visible within the failure zone after the conic frustum is removed.

8.6 *Recording Other Test Information*—Record when and where (location in element) the test was performed. Record the orientation of the test surface (vertical, horizontal, or overhead). Record if there were any abnormalities in the loading cycle. Record if there were any abnormalities in the surface in contact with the bearing ring. If conic frustum is extracted, examine frustum and record any abnormal features.

## 9. Calculation

9.1 Convert gauge readings to pullout force on the basis of relationship developed in accordance with Annex A1.

9.2 Compute the average and standard deviation of the pullout forces that represent tests of a given concrete placement.

## 10. Report

10.1 Report the following information:

10.1.1 Dimension of the pullout insert and bearing ring (sketch or define dimensions),

10.1.2 Identification by which the specific location of the pullout test can be identified,

10.1.3 Date and time when the pullout test was performed.

10.1.4 For tests to failure, maximum pullout load of individual tests, average, and standard deviation, kN. For tests to a specified load, the pullout load applied in each test, kN.

10.1.5 Description of any surface abnormalities beneath the reaction ring at the test location,

10.1.6 Abnormalities in the conic frustum, if required to be extracted,

10.1.7 Abnormalities in the loading cycle,

10.1.8 Concrete curing methods used and moisture condition of the concrete at time of test, and

10.1.9 Other information regarding unusual job conditions that may affect the pullout strength.

## 11. Precision and Bias

11.1 *Single Operator Precision*—Based on the data summarized in ACI PRC-228.1 (14) for cast-in-place pullout tests with embedment of about 25 mm, the average coefficient of variation for tests made on concrete with maximum aggregate of 19 mm by a single operator using the same test device is

8 %.<sup>5</sup> Therefore, the range in individual test results, expressed as a percentage of the average, should not exceed the following:

Number of Tests	Acceptable range, (percent of average)
5	31 %
7	34 %
10	36 %

Similar values of within-test variability have been reported for post-installed pullout tests of the same geometry as cast-in-place tests (15).

NOTE 15—If the range of tests results exceeds the acceptable range, further investigation should be carried out. Abnormal test results could be due to improper procedures or equipment malfunction. The user should

<sup>5</sup> This number represents the (1s%) limit as described in Practice C670.

investigate potential causes of outliers and disregard those test results for which reasons for the outlying results can be identified positively. If there are no obvious causes of the extreme values, it is probable that there are real differences in concrete strength at different test locations. These differences could be due to variations in mixture proportions, degree of consolidation, or curing conditions.

11.2 *Multi-Operator Precision*—Test data are not available to develop a multi-operator precision statement.

11.3 *Bias*—The bias of this test method cannot be evaluated because pullout strength can only be determined in terms of this test method.

## 12. Keywords

12.1 concrete strength; in-place strength; in-place testing; pullout test

## ANNEX

### (Mandatory Information)

#### A1. STANDARDIZATION OF PULLOUT-HYDRAULIC LOADING SYSTEM

A1.1 The objective of the procedure in this annex is to establish a relationship between the reading of the pullout force measuring system and the tensile force in the shaft used to pullout the insert. This relationship is established using alternative approaches as indicated in Fig. A1.1. In general, standardization is achieved by correlating the gauge reading of the pullout loading system with the force measured by a testing machine that has been verified in accordance with Practices E4 or measured with a Class A load cell that has been calibrated in accordance with Practice E74. The time interval between testing machine verifications or load cell calibrations shall be as defined in Practices E4 or E74.

A1.2 Position the pullout loading system on the force measurement apparatus. Align all components so that the pullout force is concentric with the loading system and the force measurement system. Use spherical seats or other similar means to reduce bending effects in the loading system.

NOTE A1.1—If a compression-testing machine is used to measure the force, the bearing blocks should be protected against damage. Cold-rolled steel plate at least 13 mm thick is recommended.

A1.3 Using the pullout loading system, apply increasing loads over the operating range, and record the gauge reading

and the corresponding force measured by the testing machine or load cell. Take readings at approximately 10 load levels distributed over the operating range of the pullout loading system.

NOTE A1.2—Low values of force should be avoided in the standardization process because the effects of friction may introduce significant errors. The manufacturer should provide the operating range of the pullout loading system.

A1.4 Use the readings obtained in A1.3 to calculate an appropriate regression equation using the least-squares curve-fitting method.

NOTE A1.3—Appendix X2 provides an example to illustrate the development of the regression equation. Additional information is provided in Practice E74.

A1.5 The difference between the force based on the regression equation and the force measured by the testing machine or the load cell shall not be greater than  $\pm 2\%$  of the measured force over the operating range. If this tolerance is not met, the pullout loading system shall not be used until this requirement is satisfied.