



Designation: E345 – 24

Standard Test Methods of Tension Testing of Metallic Foil¹

This standard is issued under the fixed designation E345; the number immediately following the designation indicates the year of original adoption or, in the case of revision, the year of last revision. A number in parentheses indicates the year of last reapproval. A superscript epsilon (ϵ) indicates an editorial change since the last revision or reapproval.

This standard has been approved for use by agencies of the U.S. Department of Defense.

1. Scope*

1.1 These test methods cover the tension testing of metallic foil at room temperature. Exception to these methods may be necessary in individual specifications or test methods for a particular material.

1.2 *Units*—The values stated in SI units are to be regarded as standard. The values given in parentheses are mathematical conversions to inch-pound units that are provided for information only and are not considered standard.

1.3 *This standard does not purport to address all of the safety concerns, if any, associated with its use. It is the responsibility of the user of this standard to establish appropriate safety, health, and environmental practices and determine the applicability of regulatory limitations prior to use.*

1.4 *This international standard was developed in accordance with internationally recognized principles on standardization established in the Decision on Principles for the Development of International Standards, Guides and Recommendations issued by the World Trade Organization Technical Barriers to Trade (TBT) Committee.*

2. Referenced Documents

2.1 *ASTM Standards:*²

B193 Test Method for Resistivity of Electrical Conductor Materials

E4 Practices for Force Calibration and Verification of Testing Machines

E6 Terminology Relating to Methods of Mechanical Testing
E8/E8M Test Methods for Tension Testing of Metallic Materials

E29 Practice for Using Significant Digits in Test Data to Determine Conformance with Specifications

¹ These test methods are under the jurisdiction of ASTM Committee E28 on Mechanical Testing and are the direct responsibility of Subcommittee E28.04 on Uniaxial Testing.

Current edition approved Jan. 1, 2024. Published February 2024. Originally approved in 1968. Last previous edition approved in 2016 as E345 – 16. DOI: 10.1520/E0345-24.

² For referenced ASTM standards, visit the ASTM website, www.astm.org, or contact ASTM Customer Service at service@astm.org. For *Annual Book of ASTM Standards* volume information, refer to the standard's Document Summary page on the ASTM website.

E252 Test Method for Thickness of Foil, Thin Sheet, and Film by Mass Measurement

E796 Test Method for Ductility Testing of Metallic Foil (Withdrawn 2009)³

E2309 Practices for Verification of Displacement Measuring Systems and Devices Used in Material Testing Machines

3. Terminology

3.1 Refer to Terminology E6 for the definitions of the following terms used in this standard: accuracy, ductility, elongation, elongation after fracture, elongation at fracture, extensometer, gauge length, length of the reduced parallel section, reduced parallel section, reduction of area, stress-strain diagram, tensile strength, yield strength, and upper yield strength.

4. Significance and Use

4.1 Tension tests provide information on the strength and ductility of materials under uniaxial tensile stresses. This information may be useful in comparisons of materials, alloy development, quality control, and design.

4.2 The results of tension tests from selected portions of a part or material may not totally represent the strength and ductility of the entire end product of its in-service behavior in different environments.

4.3 These test methods are considered satisfactory for acceptance testing of commercial shipments, since the methods have been used extensively for these purposes.

4.4 Tension tests provide a means to determine the ductility of materials through the measurement of elongation or reduction of area. However, as specimen thickness is reduced, tension tests may become less useful for determining ductility. For these purposes Test Method E796 is an alternative procedure for measuring ductility.

4.5 Different industries differentiate between foil and sheet at different thicknesses.

NOTE 1—In 2013, to harmonize with international standards, the Aluminum Association revised its definition of foil to include thicknesses

³ The last approved version of this historical standard is referenced on www.astm.org.

*A Summary of Changes section appears at the end of this standard

less than or equal to 0.2 mm (0.008 in.).

4.6 This standard differs from Test Methods E8/E8M in that it permits determining the specimen thickness by weighing (7.3) and determining the elongation from crosshead displacement for some specimens (7.8).

4.7 It is impossible for this standard to define the thickness range for every possible alloy where this standard should be used instead of Test Methods E8/E8M or other tensile test standards. Superior results for a specific alloy and thickness could be obtained by measuring the specimen thickness by weighing (7.3) to avoid damaging the material and to obtain sufficient accuracy. In addition, it may be acceptable for a given alloy and thickness to determine the elongation from crosshead displacement in cases where conventional extensometers that contact the specimen or scribed gauge marks could damage the specimen or affect the test results.

5. Apparatus

5.1 Testing Machines:

5.1.1 The force-measuring system of the testing machine shall conform to the requirements of Practices E4. The forces used in determining tensile strength, yield strength, and upper yield strength shall be within the verified range of forces of the testing machine as defined in Practices E4.

5.1.2 If Type B specimens are used, the displacement-measuring system of the testing machine shall conform to Practices E2309 Class D.

5.2 Gripping Devices:

5.2.1 General—Various types of gripping devices may be used to transmit the measured force applied by the testing machine to the test specimen. To ensure axial tensile stress

within the gauge length, the axis of the test specimen should coincide with the center line of the heads of the testing machine.

NOTE 2—Any departure from this center line could introduce bending stresses that are not included in the usual stress computation (force divided by cross-sectional area).

5.2.2 Wedge grips may be used.

NOTE 3—Testing machines usually are equipped with wedge grips. These wedge grips generally furnish a satisfactory means of gripping long specimens of ductile materials in the thicker foil gauges. If, for any reason, one wedge or jaw of a pair advances farther than the other as the grip tightens, an undesirable bending stress could be introduced.

5.2.2.1 When liners are used behind the wedges, they shall be of the same thickness and their faces shall be flat and parallel.

5.2.2.2 For proper gripping, the entire length of the serrated face of each wedge should be in contact with the specimen. A buffer material such as 320-grit silicon carbide paper may be inserted between the specimen and serrated faces to minimize tearing of specimens.

5.2.3 Smooth-face grips may be used.

NOTE 4—For foils less than 0.076 mm (0.0030 in.) thickness, smooth-face grips have been used successfully with gripping pressure of about 0.7 MPa (100 psi) for each 0.025 mm (0.00098 in.) of specimen thickness.

6. Test Specimen

6.1 General—Test specimens shall be prescribed in the product specification for the material being tested. If a Type A specimen is used, all specimen dimensions, test procedures, and calculations shall comply with those shown in Test Methods E8/E8M.

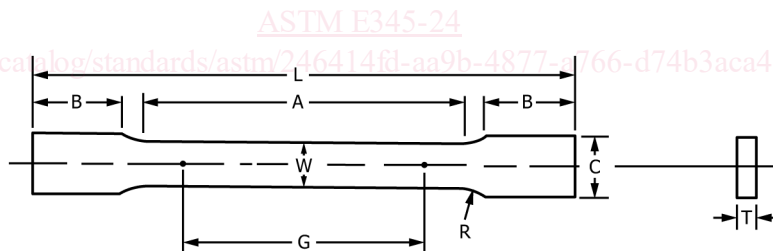

	Dimensions			
	Specimen			
	Type A		Type B	
	mm	in.	mm	in.
G—Gauge length	50.0 ± 0.1	(1.96 ± 0.004)	125	(5.00)
W—Width	12.50 ± 0.25	(0.500 ± 0.010)	12.5	(0.500)
T—Thickness	thickness of foil		thickness of foil	
R—Radius of fillet, min	19	(0.75)
L—Overall Length, min	200	(8)	230	(9.0)
A—Length of reduced parallel section, min	60	(2.25)
B—Length of grip section, min	50	(2)
C—Width of grip section, approx.	20	(0.8)	12.5	(0.500)

NOTE 1—For Type A specimens, the ends of the reduced parallel section shall not differ in width by more than 0.05 mm (0.002 in.). Also, there may be a gradual decrease in width from the ends to the center, but the width at either end shall not be more than 0.10 mm (0.005 in.) larger than the width at the center.

NOTE 2—The dimension T is the thickness of the test specimen as provided for in the applicable material specifications.

NOTE 3—For Type B specimens, measure the gauge length, G, to an accuracy of 0.25 mm (0.01in.).

FIG. 1 Foil Tension Test Specimen

6.2 *Type A Specimen*—Type A specimens shall be in accordance with the 12.5 mm (0.500 in.) sheet-type specimen shown in Fig. 1. To avoid lateral buckling in tests of some materials, the minimum radius of the fillet should be 19 mm (0.75 in.), or the width of the grip ends should be only slightly larger than the width of the reduced parallel section, or both.

6.3 *Type B Specimens*—Type B specimens shall be in accordance with the 12.5 mm (0.500 in.) wide parallel sided specimen shown in Fig. 1.

7. Procedures

7.1 *Type A Specimen Preparation:*

7.1.1 The specimens may be machined in packs by use of a milling-type cutter.

7.1.2 Examine the machined specimens under about 20x magnification to determine that the edges are smooth and that there are no surface scratches or creases. Reject specimens that show discernible scratches, creases, or edge discontinuities.

NOTE 5—Periodically sharpening or renewing the milling-type cutter will reduce scratches, creases, and edge discontinuities.

7.1.3 The specimens may be interleaved with hard aluminum sheet, a plastic, or other suitable material.

7.2 *Type B Specimen Preparation:*

7.2.1 The specimens, particularly of soft and of thin hard metals, may be prepared by shearing, for example, by use of a double-bladed cutter⁴ (Fig. 2) or by slitting. The cutting edges should be lubricated, if necessary, with a material such as stearic acid in alcohol or another suitable material.

⁴ The sole source of supply of the Thwing-Albert JDC-50 precision cutter known to the committee at this time is Thwing-Albert Instrument Co., 14 W. Collings Ave. West Berlin, NJ 08091. If you are aware of alternative suppliers, please provide this information to ASTM International Headquarters. Your comments will receive careful consideration at a meeting of the responsible technical committee,¹ which you may attend.

7.2.2 Examine the finished specimens under about 20x magnification to determine that the edges are smooth and there are no surface scratches or creases. Reject specimens that show discernible surface scratches, creases, or edge discontinuities.

7.3 *Specimen Measurement:*

7.3.1 *Thickness:*

7.3.1.1 The thickness of hard or soft foils may be determined by weighing using Test Method E252 or by the use of other measuring devices such as an optimizer, an electrical-type measuring device, or a micrometer.

7.3.1.2 When determining the thickness by weighing using Test Method E252, weigh at least two specimens together when it is practical. When Type B specimens are not used, a sample in accordance with Test Method E252 may be used if it is taken from an area adjacent to the area from which the test specimens were taken.

7.3.1.3 When Type B tension test specimens or samples are weighed to determine their thickness, the established value of density for the material should be used in the equation

$$T = \frac{W}{(AD)} \tag{1}$$

where:

- T = thickness of specimen or sample,
- W = mass of specimen or sample,
- A = area of specimen or sample, and
- D = density of material.

7.3.1.4 Regardless of the measurement method, measure the thickness of the specimen to either 2 % of the thickness or 0.0025 mm (0.00010 in.), whichever is more accurate.

7.3.2 *Width*—Measure and record the specimen width dimension to the nearest 0.025 mm (0.0010 in.).

7.4 *Speed of Testing*—Unless otherwise specified, any convenient speed of testing may be used up to one half the specified yield strength or upper yield strength, or up to one

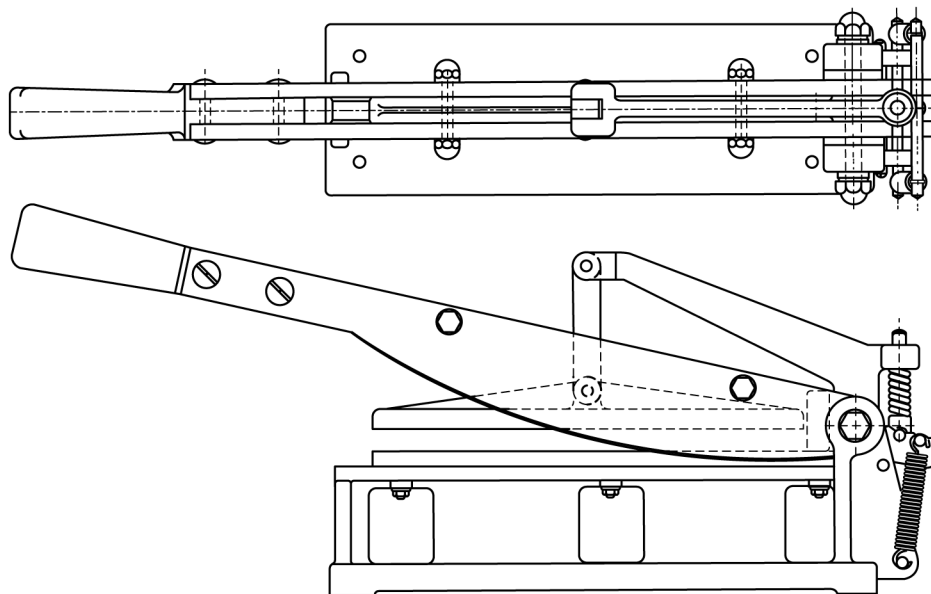

FIG. 2 Double-Bladed Cutter for Making Type B Specimens