



Designation: G72/G72M – 24

Standard Test Method for Autogenous Ignition Temperature of Liquids and Solids in a High-Pressure Oxygen-Enriched Environment¹

This standard is issued under the fixed designation G72/G72M; the number immediately following the designation indicates the year of original adoption or, in the case of revision, the year of last revision. A number in parentheses indicates the year of last reapproval. A superscript epsilon (ϵ) indicates an editorial change since the last revision or reapproval.

1. Scope

1.1 This test method covers the determination of the temperature at which liquids and solids will spontaneously ignite. These materials must ignite without application of spark or flame in a high-pressure oxygen-enriched environment.

1.2 This test method is intended for use at pressures of 2.1 MPa to 20.7 MPa [300 psi to 3000 psi]. The pressure used in the description of the method is 10.3 MPa [1500 psi], and is intended for applicability to high pressure conditions. The test method, as described, is for liquids or solids with ignition temperature in the range from 60 °C to 500 °C [140 °F to 932 °F].

NOTE 1—Test Method G72/G72M normally utilizes samples of approximately 0.20 ± 0.03 -g mass, a starting pressure of 10.3 MPa [1500 psi] and a temperature ramp rate of 5 °C/min. However, Autogenous Ignition Temperatures (AIT) can also be obtained under other test conditions. Testing experience has shown that AIT testing of volatile liquids can be influenced by the sample pre-conditioning and the sample mass. This will be addressed in the standard as Special Case 1 in subsection 8.2.2. Testing experience has also shown that AIT testing of solid or non-volatile liquid materials at low pressures (that is, < 2.1 MPa) can be significantly influenced by the sample mass and the temperature ramp rate. This will be addressed in the standard as Special Case 2, in subsection 8.2.3. Since the AIT of a material is dependent on the sample mass/configuration and test conditions, any departure from the standard conditions normally used for Test Method G72/G72M testing should be clearly indicated in the test report.

1.3 This test method is for high-pressure pure oxygen. The test method may be used in atmospheres from 0.5 % to 100 % oxygen.

1.4 An apparatus suitable for these requirements is described. This test method could be applied to higher pressures and materials of higher ignition temperature. If more severe requirements or other oxidizers than those described are desired, care must be taken in selecting an alternative safe apparatus capable of withstanding the conditions.

¹ This test method is under the jurisdiction of ASTM Committee G04 on Compatibility and Sensitivity of Materials in Oxygen Enriched Atmospheres and is the direct responsibility of Subcommittee G04.01 on Test Methods.

Current edition approved Jan. 1, 2024. Published February 2024. Originally approved in 1982. Last previous edition approved in 2015 as G72/G72M – 15. DOI: 10.1520/G0072_G0072M-24.

1.5 The values stated in either SI units or inch-pound units are to be regarded separately as standard. The values stated in each system may not be exact equivalents; therefore, each system shall be used independently of the other. Combining values from the two systems may result in non-conformance with the standard.

1.6 *This standard does not purport to address all of the safety concerns, if any, associated with its use. It is the responsibility of the user of this standard to establish appropriate safety, health, and environmental practices and determine the applicability of regulatory limitations prior to use.*

1.7 *This international standard was developed in accordance with internationally recognized principles on standardization established in the Decision on Principles for the Development of International Standards, Guides and Recommendations issued by the World Trade Organization Technical Barriers to Trade (TBT) Committee.*

2. Referenced Documents

2.1 *ASTM Standards:*²

D1193 Specification for Reagent Water

E177 Practice for Use of the Terms Precision and Bias in ASTM Test Methods

E691 Practice for Conducting an Interlaboratory Study to Determine the Precision of a Test Method

G93 Guide for Cleanliness Levels and Cleaning Methods for Materials and Equipment Used in Oxygen-Enriched Environments

2.2 *Federal Specification:*

BB-O-925 Oxygen, Technical, Gas and Liquid³

2.3 *Other Documents:*

MNL 36 Safe Use of Oxygen and Oxygen Systems: Guidelines for Oxygen System Design, Materials, Selection, Operations, Storage, and Transportation⁴

² For referenced ASTM standards, visit the ASTM website, www.astm.org, or contact ASTM Customer Service at service@astm.org. For *Annual Book of ASTM Standards* volume information, refer to the standard's Document Summary page on the ASTM website.

³ Available from U.S. Government Printing Office Superintendent of Documents, 732 N. Capitol St., NW, Mail Stop: SDE, Washington, DC 20401, <http://www.access.gpo.gov>.

⁴ ASTM Manual Series, Available from ASTM International, 100 Barr Harbor Drive, W. Conshohocken, PA 19428.

3. Summary of Test Method

3.1 This autogenous ignition temperature test method is designed to expose solid or liquid sample material to increasing temperature in a high-pressure reaction vessel. The reaction vessel (bomb), including a sample holding assembly, is pressurized with the oxygen-enriched environment. The bomb is heated in an electric furnace at a predetermined rate. The temperature of the sample-holding assembly is monitored as a function of time by means of a thermocouple and recording potentiometer.

3.2 The minimum temperature required to cause the sample to ignite spontaneously is determined at any selected system pressure. The point at which spontaneous ignition occurs is denoted by a sudden rise in temperature and the destruction of the sample. The amount of rise in temperature is related to the sample size. A sample size is selected to prevent damage to the equipment caused by exceeding safe system pressure or temperature limits because of the temperature rise.

3.3 The system is pressurized to the desired test pressure at the start of the test. During the test as the temperature is increased, the pressure increases. No effort is made to control the pressure during the test. It is monitored only so that the pressure does not exceed a safe limit for the test equipment.

4. Significance and Use

4.1 Most organic liquids and solids will ignite in a pressurized oxidizing gas atmosphere if heated to a sufficiently high temperature and pressure. This procedure provides a numerical value for the temperature at the onset of ignition under carefully controlled conditions. Means for extrapolation from this idealized situation to the description, appraisal, or regula-

tion of fire and explosion hazards in specific field situations, are not established. Ranking of the ignition temperatures of several materials in the standard apparatus is generally in conformity with field experience.

4.2 The temperature at which material will ignite spontaneously (AIT) will vary greatly with the geometry of the test system and the rate of heating. To achieve good interlaboratory agreement of ignition temperatures, it is necessary to use equipment of approximately the dimensions described in the test method. It is also necessary to follow the described procedure as closely as possible.

4.3 The decomposition and oxidation of some fully fluorinated materials releases so little energy that there is no clear-cut indication of ignition. Nor will there be a clear indication of ignition if a sample volatilizes, distilling to another part of the reaction vessel, before reaching ignition temperature.

5. Apparatus

5.1 Suitable components shall be assembled so that the specified reaction vessel (bomb), including sample-holding assembly, can be charged with oxygen and heated. The assembly shall provide a means of recording time and temperature at which ignition occurs. A suitable assembly is illustrated in Fig. 1.

5.2 *Cylinder Oxygen*, conforming to Federal Specification BB-O-925, Type I or oxygen of 99.5 % minimum purity. Oxygen of higher purity may be used if desired.

5.3 *Line Filter*, sintered tin-bronze, 5- μ m porosity, maximum pressure 206.8 MPa [30 000 psi], for 6.35-mm [1/4-in.] high-pressure tubing with a 3.18-mm [1/8-in.] port.⁶

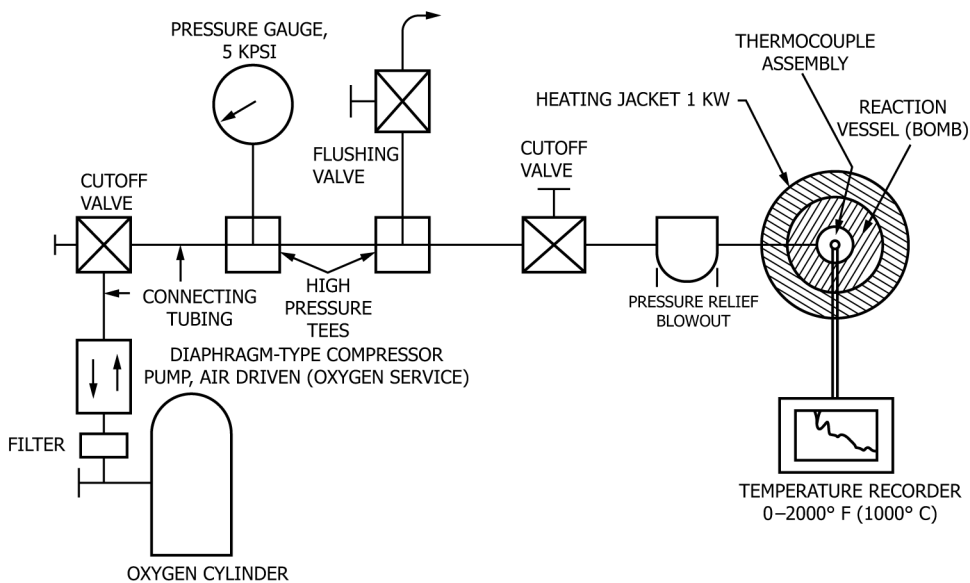

FIG. 1 AIT Equipment Assembly

⁵ Available from Compressed Gas Association (CGA), 4221 Walney Rd., 5th Floor, Chantilly, VA 20151-2923, <http://www.cganet.com>.

⁶ Catalog No. 49-14405 available from Superpressure, Inc., Silver Spring, Md. 20910 or equivalent has been found satisfactory.

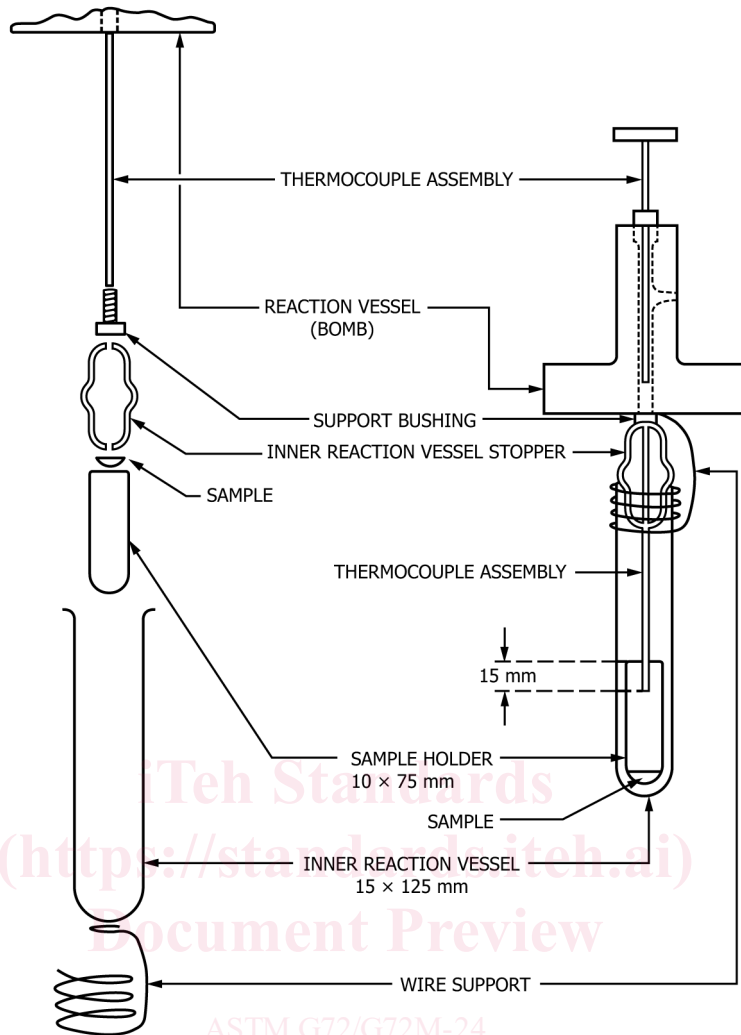

FIG. 2 Sample Holding Assembly

5.4 *Compressor Pumps*, diaphragm-type, air-driven, 10 000 psi output pressure.

5.5 *Valves*, 6.35 mm [$\frac{1}{4}$ in.] high-pressure, 206.8 MPa [30 000 psi] working pressure, nonrotating stem valves.

5.6 *Pressure Gage*, 20.7 MPa [3000 psi], 216 mm [$8\frac{1}{2}$ in.], 0.1 % F.S. Accuracy.

5.7 *Connecting Tubing*, Type 316 stainless steel, 6.35 mm [$\frac{1}{4}$ in.] high-pressure tubing, 448.1 MPa [65 000 psi] pressure rating at 37.8 °C [100 °F].

5.8 *High-Pressure Tees*, Type 316 stainless steel with gland nuts and sleeves of Type 416 stainless steel, 6.35 mm [$\frac{1}{4}$ in.] high-pressure. All connection fittings shall be of cold-drawn Type 316 stainless steel, 413.7 MPa [60 000 psi] maximum pressure, tubing size 6.35 mm [$\frac{1}{4}$ in.] high-pressure and 14.3-mm [$\frac{9}{16}$ -in.] insertion depth.

5.9 *Pressure-Relief Blowout with Rupture Discs*, pressure-relief blow-out assembly, Type 316 stainless steel, 6.35 mm

[$\frac{1}{4}$ in.] high-pressure, angle type with 48.3 MPa [7000 psi] at 22.2 °C [72 °F] rupture disks.

5.10 *Reaction Vessel (Bomb)*—A suitable reaction vessel for the test method is cylindrical, approximately 65 mm [$2\frac{5}{16}$ in.] in outside diameter and 298 mm [$11\frac{3}{4}$ in.] long and weighs 9.75 kg [21½ lb]. The vessel is bored from a solid forging of AISI 316SS [$8\frac{1}{4}$ in.] depth, with a volume equal to approximately 110 mL. The maximum working pressure at 427 °C [800 °F] is 82.7 MPa [12 000 psi].

5.11 *Thermocouple Assembly*—A Chromel-Alumel thermocouple with suitable high-pressure fittings for the reaction vessel with a 203-mm [8-in.] thermocouple to extend into the reaction chamber.

5.12 *Heating Jacket*—A 230-V, 1000-W single-phase heating jacket designed to fit the reaction vessel should be used.

5.13 *Recorder*, 0 °C to 1000 °C [0 °F to 2000 °F]—A strip chart recording pyrometer in the temperature range for the test